



Files: S/PDP 16-04

DATE: May 10, 2017

TO: PLANNING COMMISSION

FROM: Mike Sawley, Senior Planner (879-6812, mike.sawley@chicoca.gov)

RE: Faithful Estates Subdivision and Planned Development Permit
Cactus Avenue, APN 016-160-108

SUMMARY

On 04/06/17 the Planning Commission held a public hearing on the project and, on a 6-0-1 vote (Arregui absent), continued the item with a request for additional information regarding a potential bicycle path connection to North Valley Court. Pursuant to this request the applicant has provided a map showing how the connection could be made (see enclosed map date-stamped Apr 10, 2017), and Public Work Traffic Engineering staff has provided a memorandum evaluating the potential connection (see **Attachment 2**). The memorandum concludes that any gain in cyclist convenience in providing the connection would be outweighed by safety concerns. Staff's recommendation to approve the proposed map date-stamped February 14, 2017, (included as **Attachment 1D**), remains unchanged.

Recommendation:

Planning staff recommends adoption of Resolution No. 17-05 (**Attachment 1A**), approving the project, subject to the conditions contained therein.

Proposed Motion:

I move that the Planning Commission adopt Resolution No. 17-05, approving the Faithful Estates Subdivision and Planned Development Permit (S/PDP 16-04), subject to the conditions of approval contained therein.

BACKGROUND

For background information, including staff's analysis for the project, see the agenda report from the 04/06/17 Commission meeting, **Attachment 1**. The report has been updated to correct errors as noted during staff's presentation at the 04/06/17 meeting.

PUBLIC CONTACT

A 10-day public hearing notice was mailed to all landowners and residents within 500 feet of the site, and a legal notice was published in the *Chico Enterprise Record*. Correspondence received following the 04/06/17 meeting is included under **Attachment 3**.

DISTRIBUTION:

PC Distribution

SP Sawley

File: S/PDP 16-04

The Kite Group, Stephanie Marshall, P.O. Box 6822, Chico, CA 95927

Anderson Land & Investment Company, 5184 Little Grand Canyon Dr., Paradise, CA 95969

Gilbert Engineering, Wesley Gilbert, 140 Yellowstone Drive Suite 110, Chico, CA 95973

ATTACHMENTS

1. Planning Commission Agenda Report from 04/06/17 Meeting
 - A. Planning Commission Resolution No. 17-05
 - Exhibit I Conditions of Approval
 - Exhibit II Subdivision Report
 - B. Location/Notification Map
 - C. Applicants Project Description
 - D. Subdivision Map (date-stamped February 14, 2017)
 - E. Planned Development Site Plan
 - F. Color Elevations
 - G. Colors and Materials
 - H. Garage Door Examples
 - I. Lighting
 - J. Landscape Plan
2. Memorandum from Public Works Traffic Engineering (dated 05/04/17)
3. Correspondence



Files: S/PDP 16-04

DATE: March 29, 2017

TO: PLANNING COMMISSION

FROM: Mark Corcoran, Senior Planner (879-6800, mark.corcoran@chicoca.gov)

RE: Faithful Estates Subdivision and Planned Development Permit
Cactus Avenue, APN 016-160-108

SUMMARY

The applicant proposes to subdivide a 2.22-acre site into 10 lots for the development of detached single-family homes. The site is located easterly of Cactus Avenue, northerly of East Avenue. The project would yield 4.5 dwelling units per gross acre, consistent with the R1 zoning district (2.1 to 7 units per gross acre). A Planned Development Permit is necessary to comply with the SD-7 zoning overlay requirements; no deviations from Title 19 development regulations are requested.

The Architectural Review and Historic Preservation Board (ARHPB) has reviewed the site design and architecture and recommends approval, subject to conditions. Project issues include potential effects upon existing neighbors with increased residential activity associated with the project.

Recommendation:

Planning staff recommends adoption of Resolution No. 17-05 (**Attachment A**), approving the project, subject to the conditions contained therein.

Proposed Motion:

I move that the Planning Commission adopt Resolution No. 17-05, approving the Faithful Estates Subdivision and Planned Development Permit (S/PDP 16-04), subject to the conditions of approval contained therein.

BACKGROUND

The project site is located on the ~~west~~ east side of Cactus Avenue, north of East Avenue (see Location/Notification Map, **Attachment B**). The proposed project includes a Subdivision and Planned Development Permit (S/PDP) to divide the site into 10 lots for single-family residential use (see Subdivision Map, **Attachment D**, and Planned Development Site Plan, **Attachment E**).

The site is designated Low Density Residential on the General Plan diagram and zoned R1-SD7 (Low Density Residential, 2.1 to 7 units/acre, with Special Design Considerations #7 Cactus Avenue overlay districts). Surrounding land uses include single-family residential.

Subdivision Design

The proposed subdivision calls for the construction of a new public street extending west from Cactus Avenue approximately 300 feet (Road A) terminating in a cul-de-sac bulb. The existing outbuildings at the site would be removed.

A variety of lot sizes are proposed, ranging from 5,128 square feet (sf) to 14,859 sf. The average lot size is approximately 7,620 sf and the subdivision would result in a gross density of 4.5 units per acre.

Requested Subdivision Design Modifications

Modifications of Title 18R *Subdivision Design Criteria and Improvement Standards* include:

- 1) Non-right-angle and non-radial side lot lines on Lots 2, 3, 8, and 9;
- 2) Contiguous sidewalk across the frontages of adjacent lots along Street A; and
- 3) Two flag lots (lot 4 and lot 7).

The proposed subdivision also would avoid extending an existing bicycle / pedestrian path that connects North Valley Court to the southern project boundary.

Residential Development

Ten new, single-story, single-family residences are proposed. The building pad areas for each lot are shown on the proposed Site Plan of Development (see **Attachment E**, Planned Development Site Plan). Each of the residences would have a two-car garage, and at least two off-street parking spaces located in front of the garage.

Architecture proposed for the residences is single-story, stucco with a variety of rooflines and front porch configurations (see **Attachment F**, Elevations and **Attachment G**, Colors and Materials). Front elevations would feature decorative elements such as cultured stone veneer, stucco window trim, sidelight/transom windows, and garage doors painted to match the residence. The side and rear elevations of the residences would have simpler design elements.

Three example home designs are provided along with additional options for the garage doors (see **Attachments H**, Garage Door Examples). It is proposed that feature selections be left for future home buyers to choose, with the caveat that no two identical elevations would repeat adjacent to one another. Exterior lighting for the new homes would consist of typical low-intensity fixtures mounted near entryways (see **Attachment I**, Lighting).

Typical front yard landscaping plans show a variety of trees, drought-tolerant shrubs, and groundcover arranged with non-living landscape elements such as fieldstone boulders and dry creek bed features (see **Attachment J**, Preliminary Landscape Plan). Rear yards would be left to the homeowner to landscape.

Prior Review

On February 15, 2017, the Architectural Review and Historic Preservation Board (ARHPB) reviewed the proposal and voted 5-0 to recommend approval with the following additional conditions:

- *All street lighting shall be shielded and cut off from broadcasting light to the night sky.*
- *The carriage lighting proposed for the homes shall be Dark Sky lighting fixtures.*
- *The contiguous sidewalk along the northern side of Road A shall continue to a point east of the driveway for lot 1.*

These, as well as several standard conditions of approval have been attached to the resolution (see **Attachment A**).

Attachment 1

DISCUSSION

Pursuant to Chico Municipal Code (CMC) section 19.28.050, Planned Development Permit applications require review by the Board, which shall forward a recommendation to the Planning Commission regarding the site design and proposed architecture.

The proposed infill project would establish residential density at the site consistent with the R1 zoning and Low-Density Residential General Plan Designation. The design of the proposed subdivision will prevent the existing bicycle/pedestrian path from North Valley Court to connect to Road A. Avoiding the creation of this connection will allow the proposed subdivision to better integrate into the surrounding residential development allowing for consistency with General Plan Policies that encourage compatible infill development (LU-4.2, LU-4.3, and CD 5.1), and context-sensitive design (CD-5.2 and CD-5.3).

The path from North Valley Court is not included in the General Plan Bicycle/Pedestrian System Map and it is *shown but not identified described* as an existing or planned facility in the 2012 Chico Urban Area Bicycle Plan. In addition, connecting the path from North Valley Court to Road A would not substantially improve the path of travel for pedestrians or bicyclists travelling between East Avenue and Cactus Avenue.

The project design is consist with several Design Guidelines (DGs), including those that encourage a variety of home designs that include front porches and windows that face the street, consistent with DGs 4.1.11 and 4.1.14. Additional Design Guideline discussion is provided by the applicant in **Attachment C**.

Zoning Overlay - Special Design Considerations #7 (Cactus Avenue)

The SD-7 overlay zoning district applies several design standards and requirements for proposed subdivisions located along Cactus Avenue. Each of these requirements are listed below, followed by a brief staff analysis:

- 1) *Street connectivity shall be provided between developments consistent with Community Design Element policies of the General Plan, including provisions for connections to Cactus Avenue and Arch Way. Vehicular access onto Cactus Avenue shall only be allowed at such time that Cactus Avenue is improved between the access point to Cactus Avenue and East Avenue.*

Staff Analysis: The proposed subdivision provides for the development of a large, under-developed property located east of Cactus Avenue and it would not be practical to create additional public street connections to any of the surrounding roadways.

As a result of other subdivisions constructed (or currently under construction) along Cactus Avenue, the street is considered to be minimally improved between the proposed new access point and East Avenue.

- 2) *Lots fronting Cactus Avenue shall have a minimum lot size of 10,000 square feet.*

Staff Analysis: Not applicable, the project site does not front on Eaton Road include new lots fronting Cactus Avenue.

- 3) *Homes fronting Cactus Avenue shall be oriented to face Cactus Avenue and may have driveways onto Cactus Avenue.*

Staff Analysis: Not applicable, the project site does not front on Eaton Road include new homes on Cactus Avenue.

- 4) *Buildings on parcels fronting Eaton Road shall face Eaton Road, unless otherwise provided by Planned Development Permit, and shall address potential noise concerns with measures that avoid the use of sound walls.*

Staff Analysis: Not applicable, the project site does not front on Eaton Road.

- 5) *Low-level street lighting shall be utilized to maintain the rural atmosphere of the area.*

Staff Analysis: City standard 18-ft tall arched inverted lantern (aka “candy cane”) style street lighting is proposed to be installed on Street A, similar to existing street lights installed as part of other recent subdivisions along Cactus Avenue.

- 6) *All future subdivision applications shall require a Planned Development Permit.*

Staff Analysis: The proposal includes a PDP application to satisfy this requirement, no deviations from typical development regulations are requested as part of the PDP.

REQUIRED FINDINGS FOR APPROVAL

Environmental Review

This project is categorically exempt from environmental review pursuant to Section 15332 of the California Environmental Quality Act Guidelines (Infill Development Projects). This exemption applies to infill projects which: are consistent with the general plan and zoning; are on sites less than five acres in size within the City limits; substantially surrounded by urban uses; have no value as habitat for endangered, rare, or threatened species; would not result in any significant effects relating to traffic, noise, air quality, or water quality; and can be adequately served by all utilities and public services. The project meets all these criteria.

Modification to Subdivision Design Criteria Finding

As established in CMC 18.44, a modification to the city’s subdivision design criteria or improvement standards may only be approved if one of the following six findings in that chapter can be made.

- A. That the modification of design criteria and improvement standards is necessary for the subdivision and its design and improvements to be found consistent with the General Plan; or
- B. That the subdivision is subject to a specific plan which requires or authorizes the construction and installation of streets, sanitary sewers, storm drain management systems and/or other improvements in accordance with alternative design criteria and improvement standards specifically set forth therein, and that modification of the design criteria and improvement standards, as set forth in Title 18R of the CMC, is necessary or appropriate in order that improvements to be constructed and installed incident to or as a condition of approval of such subdivision will conform to the alternative design criteria and improvement standards as set forth in such specific plan; or
- C. That the subdivision or any part thereof is located in an area which contains existing streets, sanitary sewers, stormwater management systems or other improvements which do not conform to the design criteria and improvement standards, as set forth in CMC Title 18R, and that modification of such design criteria and improvement standards in the case of the proposed subdivision is necessary in order to make the streets, sanitary sewers, storm water management systems and other improvements

to be constructed and installed incident to or as a condition of approval of such subdivision compatible with such existing and nonconforming improvements; or

- D. That the subdivision or any part thereof is located in an area which contains existing streets, sanitary sewers, stormwater management systems or other improvements which do not conform to the design criteria and improvement standards, as set forth in CMC Title 18R, and that modification of such design criteria and improvement standards in the case of the proposed subdivision is necessary in order to make the streets, sanitary sewers, storm water management systems and other improvements to be constructed and installed incident to or as a condition of approval of such subdivision compatible with such existing and nonconforming improvements; or
- E. That the subdivision is of such a size or shape, and/or is affected by such topographic or soil conditions that render it impossible, impractical or undesirable, in the particular case, to conform to the design criteria and improvement standards, as set forth in Title 18R of the CMC, and that modification of such design criteria and improvement standards is necessary by reason of such subdivision characteristics or conditions; or
- F. The subdivision will include low income housing, lower income housing or senior citizen housing meeting the requirements of Chapter 4.3, Division 1, Title 7 of the California Government Code (commencing with Section 65915) and that modification of the design criteria and improvement standards in the case of proposed subdivision is demonstrably necessary in order to make such housing economically feasible.

For this project, the finding under CMC 18.44.020.D can be made:

- E. That the subdivision is of such a size or shape, and/or is affected by such topographic or soil conditions that render it impossible, impractical or undesirable, in the particular case, to conform to the design criteria and improvement standards, as set forth in Title 18R of this code, and that modification of such design criteria and improvement standards is necessary by reason of such subdivision characteristics or conditions.*

Allowing the requested modifications is desirable in this case to support efficient infill development of the project site. Subject to conditions, and for the reason cited, the requested modifications are acceptable.

Subdivision Findings (CMC Section 18.18.070.B)

Pursuant to Chico Municipal Code Section 18.18.070.B, the Planning Commission shall consider the evidence presented in the application materials, staff report, and public hearing, and shall base its action on the conformity of the subdivision map with the subdivision regulations and on the design of the proposed subdivision. In order to approve a subdivision map, the Planning Commission must find that the subdivision map and its design conform with all applicable requirements of Title 18 and Title 19 of the Chico Municipal Code, and that the subdivision map and its design are consistent with the Chico General Plan.

As supported by the Conditions of Approval and the Subdivision Report (Exhibits I and II of **Attachment A**), and this staff report, the proposed subdivision map and its design conform with the requirements of Title 18 and Title 19 of the Chico Municipal Code, and would be consistent with the Chico General Plan.

Planned Development Permit Findings (CMC Section 19.28.060)

Following a public hearing, the Planning Commission may approve or conditionally approve a

Attachment 1

planned development permit only after making all of the following findings:

1. *The proposed development is allowed within the zoning district and generally complies with all of the applicable provisions of City of Chico Title 19 regulations with modifications as specifically approved, and applicable project design guidelines.*

Single-family residential uses are permitted within the R1 district and the proposed project meets applicable provisions of Title 19. The project design is consist with several Design Guidelines (DGs), including those that encourage a variety of home designs that include front porches and windows that face the street (DGs 4.1.11 and 4.1.14). The scale and character of the new homes is similar to and compatible with adjacent developments that predominantly includes single-story, single-family homes.

2. *The proposed development would be harmonious and compatible with existing and future developments within the zoning district and general area, as well as with the land uses presently on the subject property.*

The project will be harmonious and compatible with existing adjacent developments in that it would situate new rear yards generally abutting existing rear yards on adjoining properties and would use single-story residential designs with reserved color schemes that are compatible with nearby single-family residential developments. Exterior lighting would be typical of residential uses in the area.

3. *The proposed entitlement is consistent with the General Plan.*

At 4.5 units per gross acre, the project would establish residential density at the site consistent with the R1 zoning and Low-Density Residential General Plan Designation (2.1 to 7 units per acre). Utilizing ~~larger lots with~~ single-story construction and greater setbacks for the new single-family residences balances General Plan policies that encourage compatible infill development (LU-4.2 and LU-4.3), and context-sensitive design (CD-5.2 and CD-5.3).

4. *The site is physically suitable for the type and density and/or intensity of use being proposed.*

The site is physically suitable for a single-family residential uses in that it is adjacent to existing single-family residential uses, relatively flat with no sensitive resources, and all necessary utilities and infrastructure are available to serve the project. The proposed lot sizes are ~~ample~~ adequate to accommodate future home development in compliance with all City development regulations.

5. *There are adequate provisions for public and emergency vehicle access, sanitation, water, and public utilities and services to ensure that the proposed development would not be detrimental to public health and safety.*

The new street would provide adequate public and emergency vehicle access, sanitation, water, and public utilities and services to ensure that the project would not be detrimental to public health and safety, in that the City's sanitary sewer system has adequate capacity to serve the project; domestic water will be provided by California Water Service Company; and storm water facilities will be constructed in accordance with adopted City standards. Enhanced construction materials or methods ~~would~~ may be required for the homes farthest from Cactus Avenue to reduce their susceptibility to destruction by fire.

6. *The design, location, size and operating characteristics of the proposed development would not be detrimental to the public interest, health, safety, convenience, or welfare of the City.*

The design, location, size, and operating characteristics of the project will comply with all City zoning, building, and public improvement standards, with specific subdivision modifications considered and approved herein and, therefore, the project would not be detrimental to the public interest, health, safety, convenience, or welfare of the City. The proposal limits residential construction to single-story buildings predominantly with minimum 20-foot rear setbacks, which will ensure that future homes do not unnecessarily block existing views or cause significant privacy impacts to existing adjoining properties.

7. *The proposed development is consistent with the purpose of [CMC 19.28.010].*

The project is consistent with the purpose of Chico Municipal Code Chapter 19.28 (*Planned Development*) in that it is consistent with the General Plan and design guidelines as outlined above.

PUBLIC CONTACT

A 10-day public hearing notice was mailed to all landowners and residents within 500 feet of the site, and a legal notice was published in the *Chico Enterprise Record*. As of the date of this report no comments have been received in response to the public notice.

DISTRIBUTION:

PC Distribution
SP Corcoran
File: S/PDP 16-04

External

The Kite Group, Stephanie Marshall, P.O. Box 6822, Chico, CA 95927
Anderson Land & Investment Company, 5184 Little Grand Canyon Dr., Paradise, CA 95969
Gilbert Engineering, Wesley Gilbert, 140 Yellowstone Drive Suite 110, Chico, CA 95973

ATTACHMENTS

- A. Planning Commission Resolution No. 17-05
 - Exhibit I Conditions of Approval
 - Exhibit II Subdivision Report
- B. Location/Notification Map
- C. Applicants Project Description
- D. Subdivision Map
- E. Open Space Exhibit
- F. Color Elevations
- G. Colors and Materials
- H. Garage Door Examples
- I. Lighting
- J. Landscape Plan

1
2
3
4
5

RESOLUTION NO. 17-05
RESOLUTION OF THE CITY OF CHICO PLANNING COMMISSION
APPROVING THE FAITHFUL ESTATES SUBDIVISION AND
PLANNED DEVELOPMENT PERMIT S/PDP 16-04
(The Kite Group)

6 WHEREAS, applications for a tentative subdivision map and planned development permit
7 has been submitted to subdivide a 2.22-acre site located easterly of Cactus Avenue and northerly
8 of East Avenue, identified as Assessor's Parcel No. 016-160-108, into 10 residential lots (the
9 "Project"); and

10 WHEREAS, the Planning Commission considered the Project, staff report, recommendation
11 from the Architectural Review and Historic Preservation Board, comments submitted at a noticed
12 public hearing held on April 6, 2017, and comments submitted at a subsequent noticed public
13 hearing held on May 18, 2017; and

14 WHEREAS, the Project has been determined to be categorically exempt pursuant to the
15 Guidelines for the California Environmental Quality Act, 14 CCR Section 15332 (Infill
16 Development Projects).

17 NOW, THEREFORE, BE IT RESOLVED BY THE PLANNING COMMISSION OF THE
18 CITY OF CHICO AS FOLLOWS:

- 19 1. With regard to the tentative subdivision map the Planning Commission finds that:
- 20 A. The density of the Project is 4.5 dwelling units per gross acre, which is consistent with the
21 Chico General Plan Diagram designation of Low Density Residential and the provisions
22 in Title 19 of the Chico Municipal Code;
- 23 B. No substantial evidence has been presented that would require disapproval of the Project
24 pursuant to Government Code Section 66474;
- 25 C. The requested modifications to the City's subdivision design criteria and improvement
26 standards are acceptable, as the design provides efficient residential infill, and it
27 undesirable to strictly conform to the design criteria and improvement standards set forth
28 in Title 18R for the Project; and

1 D. As supported by the subdivision report prepared for the Project, and the agenda report, the
2 Project and its design conform with both the requirements of Title 18 and 19 of the Chico
3 Municipal Code and the Chico General Plan.

4 2. With regard to the planned development permit the Planning Commission finds that:

5 A. Single-family residential uses are permitted within the R1 district and the proposed project
6 meets applicable provisions of Title 19. The project design is consist with several Design
7 Guidelines (DGs), including those that encourage a variety of home designs that include
8 front porches and windows that face the street (DGs 4.1.11 and 4.1.14). The scale and
9 character of the new homes is similar to and compatible with adjacent developments that
10 predominantly include single-story, single-family homes.

11 B. The project will be harmonious and compatible with existing adjacent developments in
12 that it would situate new rear yards generally abutting existing rear yards on adjoining
13 properties and would use single-story residential designs with reserved color schemes that
14 are compatible with nearby single-family residential developments. Exterior lighting
15 would be typical of residential uses in the area.

16 C. At 4.5 units per gross acre, the project would establish residential density at the site
17 consistent with the R1 zoning and Low-Density Residential General Plan Designation (2.1
18 to 7 units per acre). Utilizing single-story construction for the new single-family
19 residences balances General Plan policies that encourage compatible infill development
20 (LU-4.2 and LU-4.3), and context-sensitive design (CD-5.2 and CD-5.3).

21 D. The site is physically suitable for a single-family residential uses in that it is adjacent to
22 existing single-family residential uses, relatively flat with no sensitive resources, and all
23 necessary utilities and infrastructure are available to serve the project. The proposed lot
24 sizes are adequate to accommodate future home development in compliance with all City
25 development regulations.

26 E. The new street would provide adequate public and emergency vehicle access, sanitation,
27 water, and public utilities and services to ensure that the project would not be detrimental
28 to public health and safety, in that the City's sanitary sewer system has adequate capacity

1 to serve the project; domestic water will be provided by California Water Service
2 Company; and storm water facilities will be constructed in accordance with adopted City
3 standards. Enhanced construction materials or methods will be required as necessary for
4 the homes farthest from Cactus Avenue to reduce their susceptibility to destruction by
5 fire.

6 F. The design, location, size, and operating characteristics of the project will comply with all
7 City zoning, building, and public improvement standards, with specific subdivision
8 modifications considered and approved herein and, therefore, the project would not be
9 detrimental to the public interest, health, safety, convenience, or welfare of the City.

10 G. The project is consistent with the purpose of Chico Municipal Code Chapter 19.28
11 (Planned Development) in that it is consistent with the General Plan and design guidelines
12 as outlined above.

13 3. Based on all of the above, the Planning Commission hereby approves the Project, subject to
14 the conditions set forth in Exhibit I, and the provisions of the Subdivision Report set forth in
15 Exhibit II, attached hereto.

16 4. The Planning Commission hereby specifies that the materials and documents which constitute
17 the record of proceedings upon which its decision is based are located at and under the custody of
18 the City of Chico Community Development Department.

19 THE FOREGOING RESOLUTION WAS ADOPTED at a meeting of the Planning
20 Commission of the City of Chico held on May 18, 2017, by the following vote:

21 //
22 //
23 //
24 //
25 //
26 //
27 //
28 //

1 AYES:
2 NOES:
3 ABSENT:
4 ABSTAINED:
5 DISQUALIFIED:
6 ATTEST:

APPROVED AS TO FORM:

7
8
9

MARK WOLFE
Planning Commission Secretary

Andrew L. Jared, City Attorney*
City Attorney*

10
11
12
13
14
15
16
17
18
19
20
21
22
23
24
25
26
27
28

*Pursuant to The Charter of
the City of Chico, Section 906(E)

EXHIBIT “I”
CONDITIONS OF APPROVAL
Faithful Estates Subdivision and Planned Development Permit S/PDP 16-04
(The Kite Group)

1. The creation and improvement of 10 lots is authorized, as depicted on the “Crossroads Subdivision – Subdivision Map and Planned Development Permit (S/PDP 16-04)” and accompanying project materials date stamped February 14, 2017, except as revised by any other condition of approval.
2. All development shall comply with all other State and local Code provisions, as well as any applicable requirements of the Fire Department, the Public Works Department, Butte County Environmental Health, and the Community Development Department. The developer is responsible for contacting these offices to verify the need for permits.

Tentative Map Conditions:

3. In the event that all fees have not been paid prior to recordation of the final map, the following notation shall be included on the final map:

“In accordance with the provisions of the Chico Municipal Code, a transportation facility fee, park facility fee, and building and equipment fee may be assessed and levied upon the owner of any lot or parcel within this subdivision at the time a new building or structure is constructed on such lot or parcel, at the time an alteration or addition is made to an existing building or structure constructed on such lot or parcel which results in the expansion of building or structure, or at the time of a change in use of an existing building or structure constructed on the lot or parcel. In addition, a storm drainage facility fee may be assessed and levied upon the owner of any lot or parcel within this subdivision at the time such lot or parcel is first used for any residential or nonresidential purpose, at the time the area of the lot or parcel devoted to such residential or nonresidential use is expanded, or at the time of a change in the use of the lot or parcel. Such transportation facility fee, park facility fee, building and equipment fee and storm drainage facility fee will be calculated from the schedule of such fees adopted by resolution of the City Council and in effect on the date of approval of such final map or parcel map, together with any adjustments to such schedules of fees made in accordance with the provisions of the Chico Municipal Code subsequent to the date of approval of the final map or parcel map to account for any changes in the type or extent of transportation facilities, park facilities, buildings and equipment and/or storm drainage facilities which will be required as a result of the development and/or use of real property during the period upon which such fees are based, any change in the estimated cost of the transportation facilities, park facilities, buildings and equipment and/or storm drainage facilities upon which such fees are based, or any change in that portion of the estimated cost of such transportation facilities, park facilities, buildings and equipment and/or storm drainage facilities which cannot be funded from revenue sources available to the City other than such fees.”
4. Prior to recording the final map, any taxes and/or assessments against the property shall be paid.

5. Impacts to school facilities within the Chico Unified School District shall be fully mitigated by payment of school impact fees to the extent permitted by State Law.

Planned Development Permit Conditions:

6. All approved building plans, final maps and permits shall note that the project shall comply with The Faithful Estates Subdivision and Planned Development Permit (S/PDP 16-04).
7. Planned Development Permit 16-04 does not authorize any exceptions or deviations from Title 19 of the Chico Municipal Code. Future construction shall comply with all applicable requirements of Title 19.
8. The approval documents for this project include the following exhibits:
 - a. Applicant's Project Description, date-stamped Nov 28, 2016;
 - b. Faithful Estates Subdivision Map, date-stamped Feb 14, 2017;
 - c. Planned Development Site Plan, date-stamped Feb 14, 2017;
 - d. Residential Elevations (6 sheets) date-stamped Nov 28, 2016;
 - e. Colors and Materials (stucco, stone, and trim), date-stamped Nov 28, 2016;
 - f. Garage Examples, date-stamped Nov 28, 2016;
 - g. Lighting Examples, date-stamped Nov 28, 2016; and
 - h. Preliminary Landscape Plan, date-stamped Nov 28, 2016.
9. All wall-mounted utilities and roof or wall penetrations, including vent stacks, utility boxes, exhaust vents, gas meters and associated equipment, shall be screened by appropriate materials and colors, illustrated or notated on the building plans as requiring screening, and subject to approval by Planning staff prior to issuance of a certificate of occupancy.
10. Tree removal shall be subject to the in-lieu fee payment requirements set forth by Chico Municipal Code 16.66 and adopted City fee schedule. In-lieu fees shall be paid prior to issuance of any certificates of occupancy within the project.
11. Private yard fencing shall use steel posts.
12. Concrete retaining walls, as opposed to wooden retaining walls, shall be used along the subdivision boundary where grade differentials exceed one foot.
13. The developer shall equip all homes constructed on Lots 4 through 7 shall be equipped with an automatic sprinkler system that provides sprinkler coverage in the attic space. The sprinkler system shall be an engineered design approved by the fire marshal.

14. All street lighting shall be shielded and cut off from broadcasting light into the night sky.
15. The carriage lighting proposed for the homes shall be Dark Sky lighting fixtures.
16. The contiguous sidewalk along the northern side of Road A shall continue to a point east of the driveway for lot 1.



Subdivision Report

Meeting Date 4/6/17

DATE: March 22, 2017

File: S/PDP 16-04

TO: PLANNING COMMISSION

FROM: Matt Johnson, Senior Development Engineer, 879-6910
Public Works Department

RE: **Vesting Tentative Subdivision Map S/PDP 16-04 Faithful Estates Subdivision**

Exhibit "II"

This office has reviewed the vesting Tentative Subdivision Map S/PDP 16-04 Faithful Estates Subdivision and herewith submits the following findings and recommendations for same.

A. MODIFICATIONS TO TITLE 18R - DESIGN CRITERIA AND IMPROVEMENT STANDARDS OF THE CHICO MUNICIPAL CODE

The Subdivider has requested certain modifications to Titles 18R of the Chico Municipal Code (CMC). These requests have been listed on the Tentative Map application, described by the Subdivider and/or their engineer, or appear on the Tentative Map. The requests and staff recommendations are as follows:

1. **Request:** Allow non-right angle and non-radial lot lines.

Recommendation: Acceptable.

2. **Request:** Allow flags lots.

Recommendation: Acceptable.

3. **Request:** Allow contiguous sidewalks.

Recommendation: Acceptable.

THE CONDITIONS CONTAINED IN THE REMAINDER OF THIS REPORT REFLECT, WHERE APPLICABLE, THE RECOMMENDATIONS ABOVE.

B. PUBLIC FACILITY CONSTRUCTION

All improvements are to be designed and constructed in compliance with the Special Design Consideration Overlay SD-7 for Cactus Avenue.

C. PUBLIC FACILITY CONSTRUCTION

1. Streets

- a) The Subdivider shall construct City standard streets and appurtenant facilities at the following locations in conformance with the typical sections as depicted on the Tentative Map:
 - 1) Interior to subdivision - Full urban improvements.
 - 2) Adjacent to subdivision - Full urban improvements including corner bulbing as depicted on the Tentative Map.
 - 3) Exterior to subdivision - Construct and/or verify that urban improvements consistent with the Special Design Consideration Overlay SD-7 for Cactus Avenue have been completed between the access point onto Cactus Avenue and East Avenue.
- b) Street name shall be approved concurrent with the improvement plans and prior to recordation of the Final Map.

2. Storm Drainage

a) Facility Construction

The Subdivider shall design and install the following City standard storm drain facilities:

- 1) Interior to Subdivision - Curb, gutter, and an underground storm drain system with all appurtenances.
 - 2) Adjacent to Subdivision - Curb, gutter and an underground storm drain system with all appurtenances along the subdivision frontage.
 - 3) Exterior to Subdivision - Connect to existing City infrastructure.
- b) Post Construction Standard Plans
- Implement City Post Construction Standard Plans to evapo-transpire, infiltrate, harvest and reuse, or bio treat storm water runoff.

c) NPDES Requirements

Storm drain drop inlets shall be marked with Illustrative Storm Markers to achieve City of Chico NPDES Requirements.

d) Storm Drainage Master Plan

In conjunction with the first submittal of improvement plans, the Subdivider shall submit a Storm Drainage Master Plan to the Public Works Department for review and approval. Said Master Plan shall cover the entirety of the natural storm drain tributary area affected by the proposed subdivision.

The Storm Drainage Master Plan shall address the following elements:

1) Storm Water Runoff Management

The runoff management plan shall establish specific measures to accomplish the following:

- No net increase in peak flow into existing City infrastructure.
- Erosion control.
- Pollutant runoff control, including first flush mitigation, (the first 1/2-inch of runoff shall be intercepted and treated).
- Restricted area protection.
- Incorporate Best Management Practices (BMPs) per City of Chico's Best Practices Manual dated September 1998.

The plan shall stipulate the measures to be implemented and the means of implementation by the Subdivider during construction and after construction but prior to lot development.

The plan shall establish any design constraints to be placed upon both public and private facility construction.

2) Storm Drainage Analysis

The storm drain analysis shall establish tributary area, size, grade, depth, and location for all the following storm drain facilities:

- Underground pipes.
- Storm water runoff management facilities.
- Both ultimate and interim facilities serving streets exterior to the subdivision that are required to be constructed herein.

e) Statement of Effective Storm Water Disposal

The storm drainage system for this project shall meet the following standards:

- No net increase in peak flow into existing City infrastructure.
- Intercept and treat the first flush runoff (defined as the first 1/2-inch of runoff).

These standards are to be met through the preparation and implementation of a site specific storm drainage master plan which shall incorporate one or more Best Management Practices (BMPs) as set forth in the City of Chico's Best Practices Manual. A review of this project, including the project location, has been made. Based on this review, it has been concluded that the use of one or more such BMPs will provide an adequate mechanism to meet the standards set forth herein and, therefore, provide the required mitigation of storm drainage effects resulting from the project.

- f) The subdivider shall pay a storm drain fee calculated in accordance with the current fee schedule under the requirements of the Chico Municipal Code, prior to recordation of the Final Map.

3. Sanitary Sewer

a) Facility Construction

The Subdivider shall design and install an underground sanitary sewer system, with all appurtenances, serving all lots.

b) Sanitary Sewer Fees

The Subdivider shall complete an Application for Sewer Connection.

The Subdivider shall pay a sanitary sewer main fee to the City of Chico prior to recording the Final Map, plus applicable trunk line and water pollution control plant capacity fees in conjunction with building permits. All of the aforementioned fees will be subject to the terms and conditions of the Application for Sewer Connection.

4. Well and Septic Abandonment

The Subdivider shall obtain all necessary permits from the Butte County Environmental Health Department and abandon all wells and septic systems in accordance with their requirements.

5. Street Signs and Striping

The Subdivider shall install City standard street signs/regulatory signs (High Intensity Prismatic, no less than Grade V), pavement striping and pavement markings on all streets that they are required herein to construct.

6. Street Lights

The Subdivider shall install City standard street lights on steel poles with concrete bases on all streets that they are required herein to construct.

7. Street Trees

Street trees shall be planted in accordance with the recommendation of the Public Works Department.

D. MAINTENANCE

Prior to filing the Final Map, the Subdivider shall be required to make provisions to fund the maintenance of certain public improvements. The improvements to be covered shall be:

Storm water quality and quantity mitigation.

The Subdivider shall prepare the necessary documents and provide the required supporting documents. Formation of a maintenance district requires action by the City Council. The district or alternate funding mechanism shall be complete and formed prior to recordation of the Final Map.

E. SUBDIVISION GRADING

1. Soils Report

The Subdivider shall submit a Geological and/or Soils Report, prepared by a registered engineer, that includes, but is not limited to, the following:

- a) An investigation of the nature, distribution and strength of existing soils.
- b) A description of site geology.
- c) Conclusions and recommendations covering the adequacy of the site for the proposed development, storm drainage disposal, grading procedures and corrective measures.
- d) Verification that the site is suited to proposed BMPs.

2. Grading Standards

All subdivision grading shall be in conformance with Chapter 16R.22, Grading Standards, of the Chico Municipal Code.

3. Grading Plan

The Subdivider's engineer shall submit a subdivision grading plan that includes, but is not limited to, the following:

- a) The subdivision limits, contours and details of existing terrain and drainage.
- b) Existing structures or other topographic features that are to remain undisturbed.
- c) The proposed subdivision lots and streets, together with a schematic layout of the proposed storm drain system.
- d) Existing ground elevations at all corners of proposed lots.
- e) Proposed finished lot corner grades and finished pad grades.
- f) Proposed lot grades indicating lot drainage.
- g) Pertinent recommendations from the above required Geological and/or Soils Report.
- h) Pertinent construction details to assure compliance with City of Chico Grading Standards.

4. Final Grading Report

Upon completion of the subdivision grading and prior to final inspection by the City, the Subdivider's engineer shall submit a Final Grading Report that certifies the following:

- a) That final grading complies with the approved grading plan or any approved revisions.

- b) That the subdivision grading complies with the recommendations included in the Geological and/or Soils Report. Any changes made during grading that affected these recommendations shall be assessed.
- c) That the subdivision soils are adequately compacted for their intended use, in conformance with City of Chico Grading Standards. The results of all field density tests and all other substantiating data shall be included in the Final Grading Report.

The subdivision grading plan shall be submitted to the Public Works Director for review and approval prior to the start of any work and shall be considered as part of the construction plans.

F. PROPERTY CONVEYANCES

1. Dedications

In conjunction with recordation of the Final Map for this subdivision, the Subdivider shall:

- a) Dedicate public right-of-way for Street "A" as depicted on the Tentative Map.
- b) Dedicate a 10-foot-wide public service easement adjacent to public rights of way.
- c) Dedicate a 3-foot-wide public utility easement adjacent to all side lot lines.

G. OTHER PUBLIC SERVICES

1. Public Utilities

a) Underground Requirements

The Subdivider shall install the following utilities underground:

- 1) All new utilities serving this subdivision.

b) Easement Obstructions

All public utility and/or public service easements shall be kept free and clear of any and all obstructions, including but not limited to, structures, longitudinal fencing and/or soundwalls, which may impede the construction, operation and maintenance of public utility facilities within such easements.

c) Utility Company Comments

- 1) AT&T, as of the date of this report, did not respond to a request for comments.
- 2) Pacific Gas and Electric Company, as of the date of this report, did not respond to a request for comments.
- 3) California Water Service Company, as of the date of this report, did not respond to a request for comments.

2. Fire Protection

The Subdivider shall comply with all recommendations of the Fire Department, City of Chico.

3. United States Postal Service

The Subdivider shall install concrete pads for NDCBU delivery to the lots of this subdivision. The pads shall be depicted on the subdivision improvement plans and are subject to approval by both the local office of the United States Postal Service and the Community Development Department.

H. DESIGN CRITERIA AND IMPROVEMENT STANDARDS

All public improvements shall be designed in accordance with Chapter 18R.08, Design Criteria, of the Chico Municipal Code, except as modified by the conditions of approval for this subdivision.

The Subdivider shall submit improvement plans, profiles, typical sections, details and specifications to the Public Works Department for review and approval prior to the start of any construction of public improvements.

All public improvements shall be constructed in conformance with Chapter 18R.12, Improvement Standards, of the Chico Municipal Code and in conformance with the details shown on the approved improvement plans.

I. ADMINISTRATIVE REQUIREMENTS

1. Subdivision Improvement Agreement

If the public improvements required herein are not satisfactorily completed prior to recordation of the Final Map, the Subdivider shall enter into a subdivision improvement agreement in conformance with Chapter 18.36, Subdivision Improvement Requirements, of the Chico Municipal Code.

2. Subdivision Fees

a) Plan Checking Fee

The Subdivider shall pay to the City of Chico a subdivision plan checking fee upon filing the Final Map and/or improvement plans and specifications for checking in the following amount:

An initial deposit of 1½% of the estimated cost of all public and/or joint use private improvements exclusive of private utility facilities (\$750 minimum). A final fee equal to actual City costs.

b) Inspection Fee

The Subdivider shall pay to the City of Chico an inspection fee prior to commencing construction in the following amount:

An initial deposit of 2% of estimated cost of all public and/or joint use private improvements exclusive of private utility facilities. A final fee equal to actual City costs.

Recommendations and comments of all parties to whom the Tentative Map was circulated for review are on file with the respective parties and in Community Development Department.

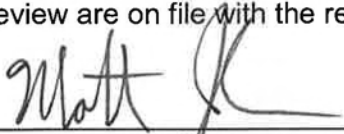

Matt Johnson, Senior Development Engineer

Distribution:

Original - Community Development Department S/PDP 16-04 File
Development Engineering Subdivision File

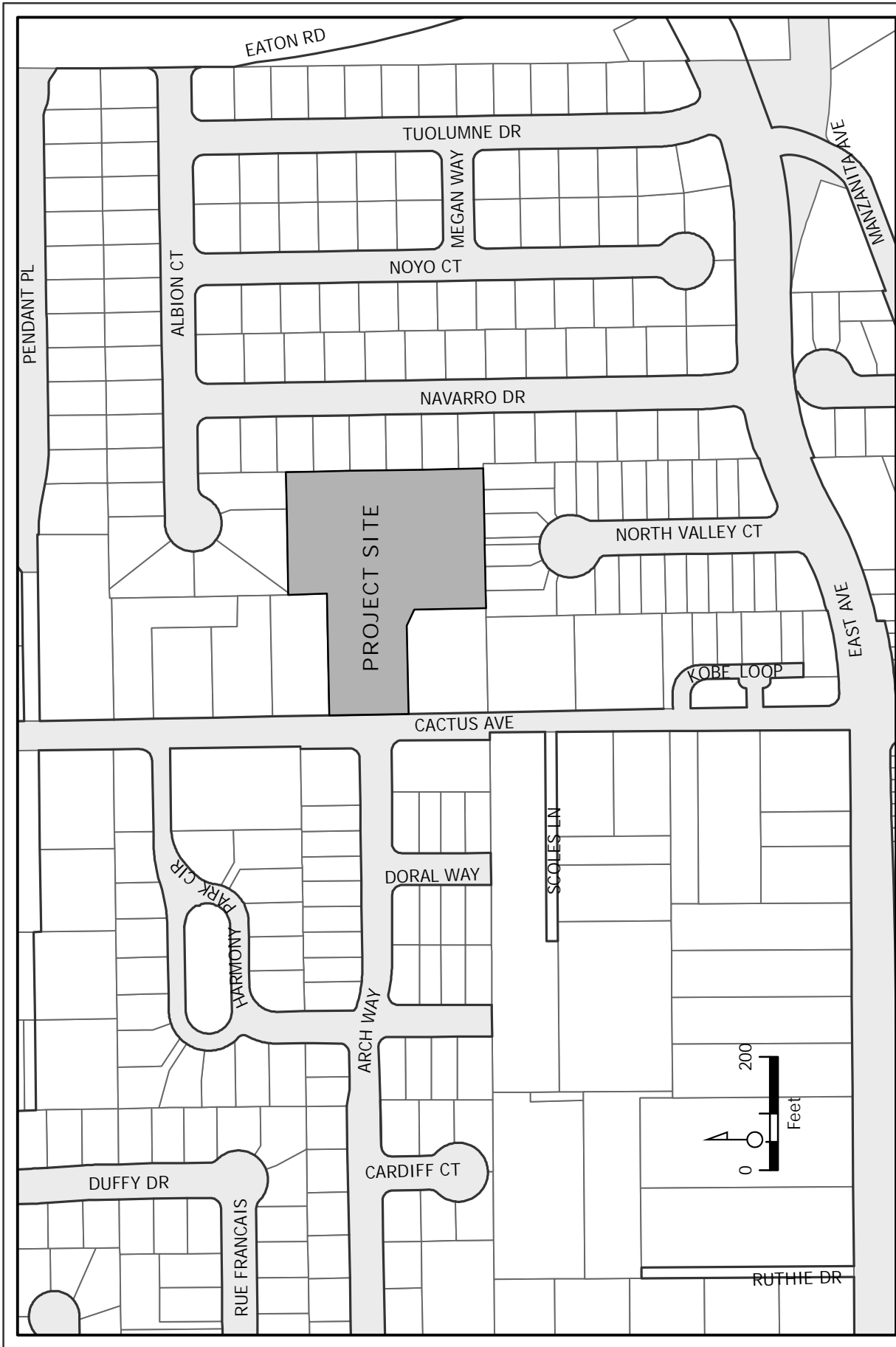

SPDP 16-04 (Faithful Estates)
 Cactus Avenue
 APN 016-160-108-000

RECEIVED**NOV 28 2016**CITY OF CHICO
PLANNING SERVICES**PROJECT DESCRIPTION*****Faithful Estates***

It is the intent of this project to incorporate many of the City of Chico Design Guidelines for Residential Project Types

Structures:

The proposed Faithful Estates is an enclave of ten single family homes on a cul-de-sac street off Cactus Avenue north of East Avenue. Three different floor plans will be offered each with a variety of roof designs and front elevation options to provide a diversity of architectural detail but still create a consistent style within the subdivision. Lot sizes range from 5000sqft to 14,000sqft which will line up with surrounding existing homes to ensure that only one new lot will back up to existing property lines. DG 1.2.11 DG 1.2.12 DG1.2.13 DG 1.2.22 DG 4.2.15

Home buyers can customize based on their individual preferences with selections of roof color, trim paint, stucco color, front elevation, garage style, lighting details and cultured stone highlights. The homes will contain large front porches in a variety of sizes which allows homeowners to enjoy and welcome the neighborhood with patio furniture, potted plants and other inviting ornamental features. DG 4.1.11 DG 4.2.43 DG 4.2.32

Garage doors will have window and hardware options and will be painted the home body or trim color at the homebuyer's discretion which will allow the main focus to be on the entirety of the architectural design. On site parking is provided by two spaces inside the garage which will allow vehicles to not be the main visual element from the street. The color pallet offers an assortment of color and textures that can be found on surrounding existing homes to provide continuity with surrounding residential neighborhoods. DG 1.1.14, DG 4.1.12, DG 1.1.11, DG 1.1.12, DG 1.1.34, DG 1.2.31, DG 4.1.63, DG 1.2.21

The HVAC units will be a split system with the furnace mounted in the attic and the air conditioners located in the back yards where they are blocked from public view by fencing. DG 3.1.35

Lighting:

Street lighting at the entrance to the neighborhood from Cactus Avenue will be of the candy cane design to be consistent with other area lighting and to retain a rural atmosphere.

Structure lighting will be wall sconces about 11 inches tall and will be placed two on the sides of the garage door and one at the front door. Lights will be of a wattage that provides for a safe environment, while creating an attractive night time streetscape. With each homeowner choosing fixture style, redundancy will be avoided while adding interest to the subdivision. DG 1.3.55, DG 4.2.44, DG 1.5.12, DG 1.5.14, DG1.5.11, DG 1.5.13, DG 1.5.17

Fencing:

New six foot high fencing will be provided around the perimeter or the property abutting existing homeowners and for side yards between the new homes.

Landscaping:

Future home owners will have the ability to customize their landscaping. Options will include turf and/or non-turf areas, small stone walls, areas of bark or rock with ground cover or combinations. This customization will produce a variety for the streetscape. The intent of this project is to propose some outdoor amenities to encourage neighborly interaction and create a sense of community. These include a community mailbox, sidewalks and front porches.

The landscape will have a low water use theme throughout to minimize the water usage and maintenance requirements but still provide eye appealing outdoor space. All landscaping will be installed to AB 1881 water usage requirements.

DG 4.1.11, DG 4.1.41

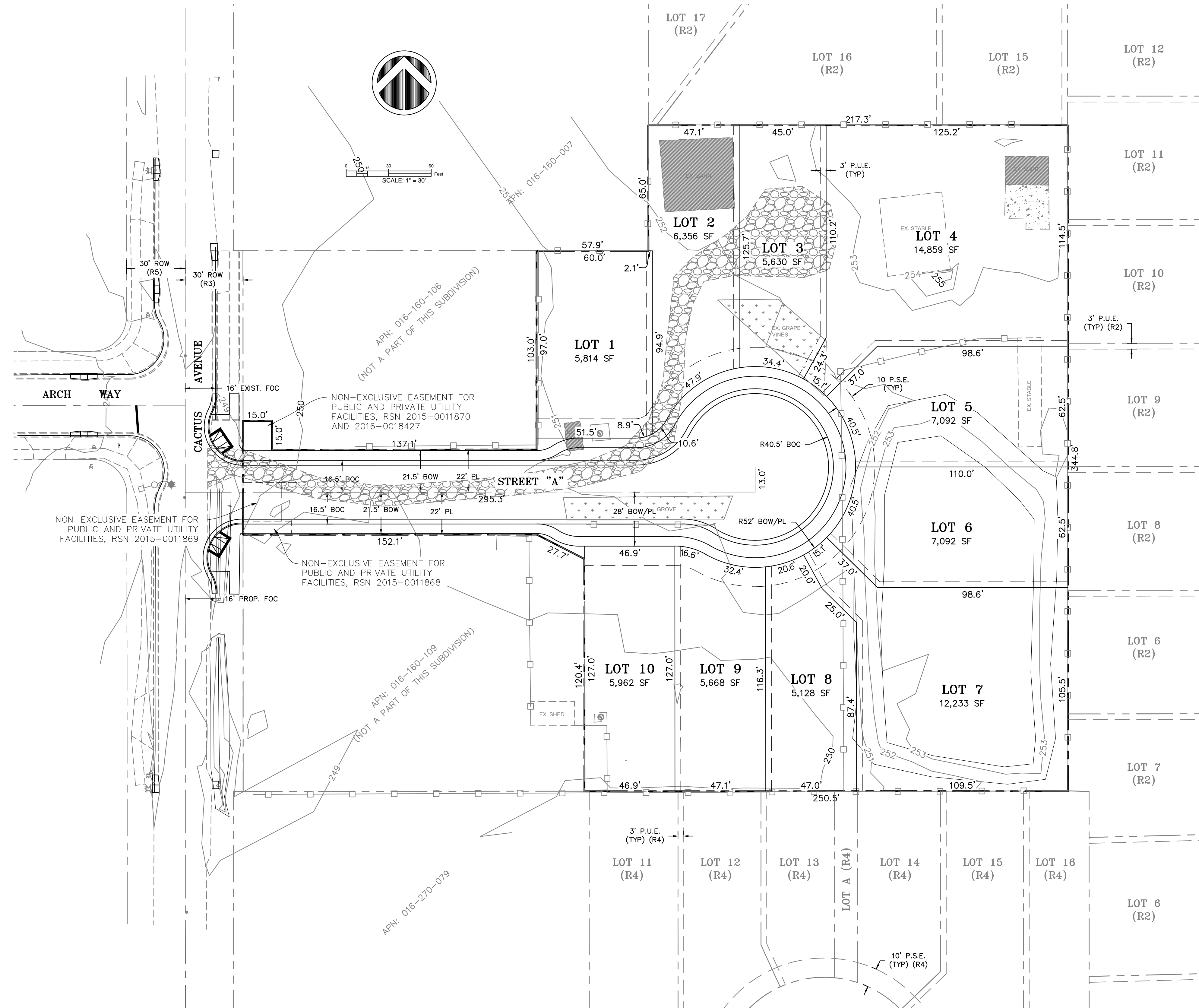

OWNER:
 APN: 016-160-108
 ANDERSON LAND & INVESTMENT COMPANY, L.P.
 5184 LITTLE GRAND CANYON DRIVE
 PARADISE, CA 95969
 (530) 591-7474

SUBDIVIDER:
 THE KITE GROUP
 P.O. BOX 6822
 CHICO, CA 95927
 (530) 521-9551

ENGINEER:
 W. GILBERT ENGINEERING
 WESLEY E. GILBERT, R.C.E. 31689
 140 YELLOWSTONE DRIVE, SUITE 110
 CHICO, CALIFORNIA 95973
 (530) 809-1315

ASSESSOR'S PARCEL NUMBER:
 016-160-108

LAND USE:
 PRESENT: VACANT
 FUTURE: SINGLE FAMILY RESIDENTIAL

ZONING:
 PRESENT: R1-SD7
 FUTURE: R1-SD7

UTILITIES:
 SANITARY SEWER: CITY OF CHICO
 WATER: CALIFORNIA WATER SERVICE COMPANY
 POWER: PACIFIC GAS & ELECTRIC
 COMMUNICATIONS: AT&T
 CABLE TV: COMCAST
 STORM DRAIN: CITY OF CHICO

- SUBDIVISION NOTES:**
- 1) SUBDIVISION INFORMATION:
 TOTAL PARCEL ACREAGE (TO CL): 2.221
 NET PARCEL ACREAGE: 2.180
 TOTAL NUMBER OF LOTS: 10
 UNITS PER ACRE: 4.50
 AVERAGE LOT SIZE: 7,620 sf
 - 2) STORM WATER QUALITY MITIGATION WILL BE PROVIDED THROUGH THE USE OF A STORM WATER INTERCEPTOR. STORM WATER QUALITY MITIGATION WILL BE PROVIDED BY OVERSIZED STORM DRAIN PIPES BENEATH STREET "A".
 - 3) GRADING WILL CONSIST OF THE CONSTRUCTION OF ROADWAYS AND BUILDINGS PADS. PRELIMINARY FINISH GRADES ARE SHOWN ON SHEET 2 OF 2.
 - 4) THE EXISTING BAMBOO GROVES AND GRAPE VINES WILL BE REMOVED.
 - 5) THE FINAL SUBDIVISION MAP WILL INCLUDE A 10' WIDE P.S.E. ACROSS THE FRONTAGE OF LOTS 1 THRU 10 AND A 3' WIDE P.U.E. ALONG EACH LOT LINE.
 - 6) LOTS 1 THRU 10 LIE IN SHADED FLOOD ZONE "X" AS SHOWN ON FIRM MAP NUMBERS 06007C0343E DATED JANUARY 6, 2011.
 - 7) THE EXISTING WELLS SHALL BE ABANDONED IN ACCORDANCE WITH BUTTE COUNTY REGULATIONS. THERE ARE NO KNOWN SEPTIC SYSTEMS LOCATED ON THE PARCEL.

- LEGEND:**
- EXISTING GROUND CONTOUR (CITY OF CHICO DATUM)
 - - - SUBDIVISION BOUNDARY
 - PROPOSED LOT LINE
 - == == EXISTING GUTTER AND SIDEWALK
 - - - PROPOSED EASEMENT
 - FG FINISH GRADE
 - EG EXISTING GROUND ELEVATION
 - FN FINISH
 - PUE PUBLIC UTILITY EASEMENT
 - PSE PUBLIC SERVICE EASEMENT
 - STE STREET TREE EASEMENT
 - ROW RIGHT OF WAY
 - BOW BACK OF WALK
 - BOC BACK OF CURB
 - PL PROPERTY LINE
 - EXISTING BUILDING TO BE REMOVED, TYP.
 - PROPOSED CURB, GUTTER AND SIDEWALK
 - ⊙ EXISTING WELL
 - EXISTING GRAVEL DRIVEWAY

RECEIVED
 Feb 14, 2017
 City of Chico
 Planning Services

- DESIGN MODIFICATIONS:**
- 1) NON-RIGHT ANGLE AND NON-RADIAL LOT LINES ON LOTS 2, 3, 8 AND 9 (18R.08.010.C.4).
 - 2) CONTIGUOUS SIDEWALK ACROSS THE FRONTAGES OF THE ADJACENT LOTS (18R.08.020.F.4).
 - 3) ALLOW FLAG LOTS FOR LOTS 4 AND 7 (18R.08.010.D.1).

- RECORD REFERENCES:**
- R1 - EIGHTEENTH SUBDIVISION OF THE JOHN BIDWELL RANCHO, BOOK 7 OF MAPS, PAGE 26.
 - R2 - BIDWELL VISTA SUBDIVISION, BOOK 118 OF MAPS, PAGES 82-85.
 - R3 - PARCEL MAP, BOOK 77 OF MAPS, PAGE 89.
 - R4 - WESTMONT SUBDIVISION (S 04-02), BOOK 162 OF MAPS, PAGES 78-80.
 - R5 - SYMM CITY SUBDIVISION (S/PDP 05-08), BOOK 169 OF MAPS, PAGES 75-77.
 - R6 - CERTIFICATE OF COMPLIANCE, RSN 2014-0042591.

THIS TENTATIVE SUBDIVISION MAP WAS PREPARED BY ME OR UNDER MY DIRECTION.

BY: _____ DATE: _____

WESLEY E. GILBERT
 R.C.E. 31689
 EXPIRES: 12/31/18



FAITHFUL ESTATES SUBDIVISION
 VESTING TENTATIVE SUBDIVISION MAP S/PDP 16-04
 (A PUBLIC STREET SUBDIVISION)

for
 THE KITE GROUP

BEING A DIVISION OF PARCEL A1 OF BOUNDARY LINE MODIFICATION 14-11 RECORDED IN RSN 2014-0042591
 CITY OF CHICO, COUNTY OF BUTTE
 STATE OF CALIFORNIA

W. GILBERT ENGINEERING
 140 YELLOWSTONE DRIVE, SUITE 110
 CHICO, CALIFORNIA 95973
 (530) 809-1315

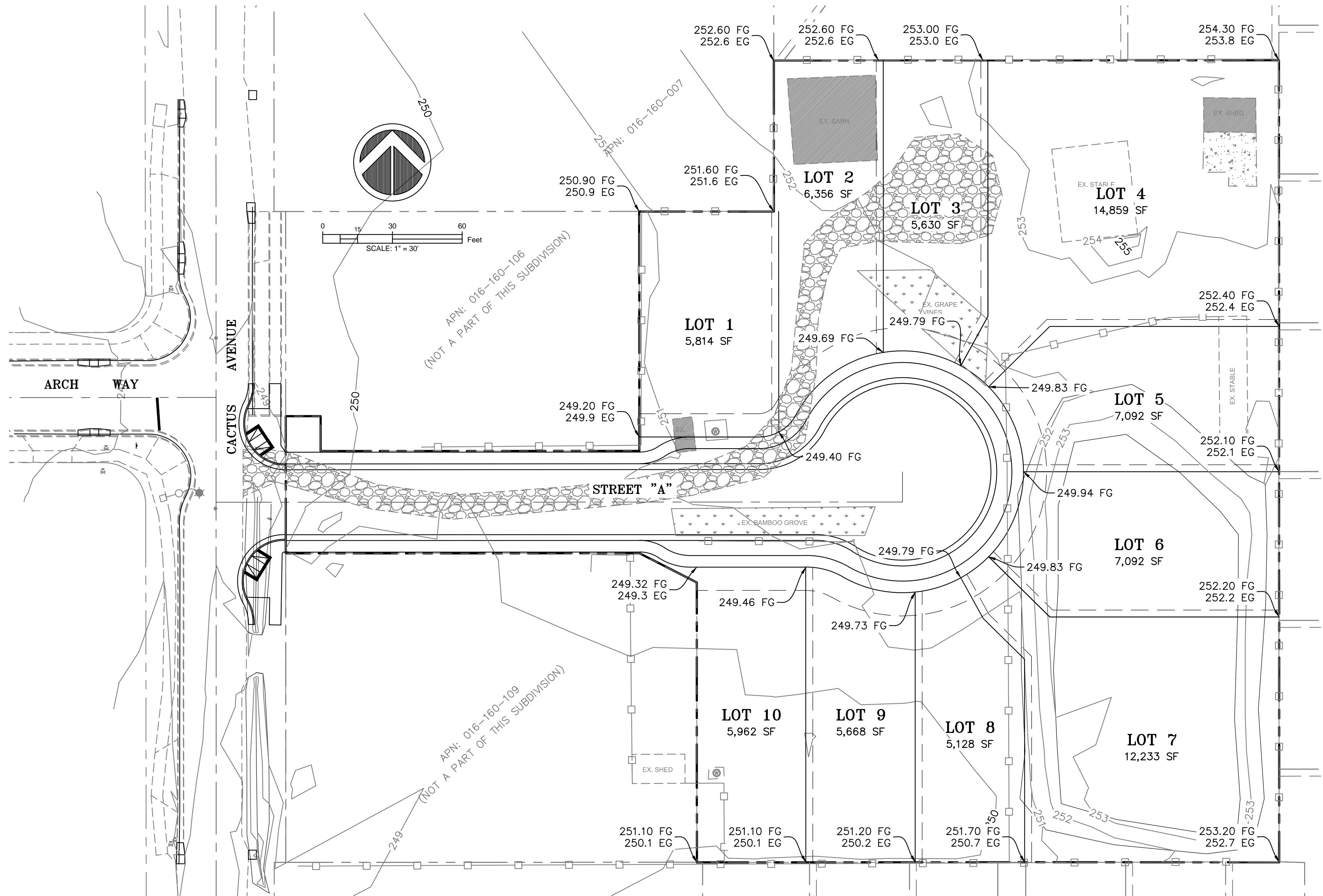

PRELIMINARY GRADING PLAN



RECEIVED
Feb 14, 2017
City of Chico
Planning Services

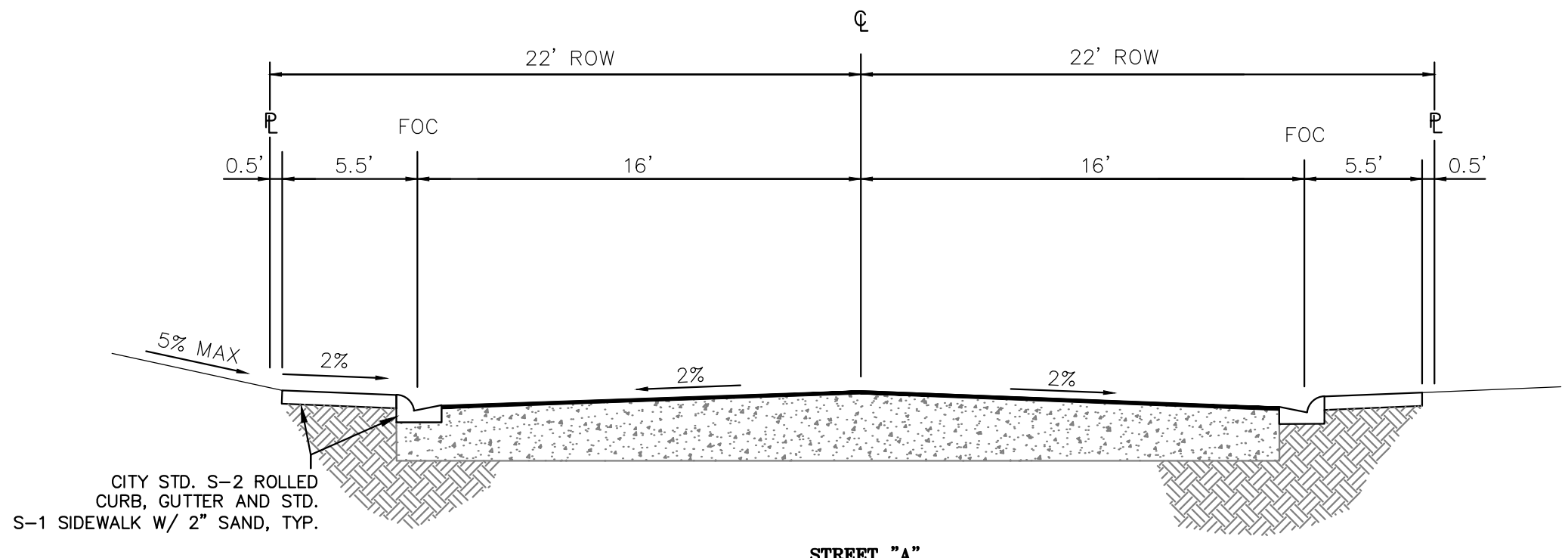

STREET "A" PUBLIC STREET WITH ON-STREET PARKING TYPICAL SECTION

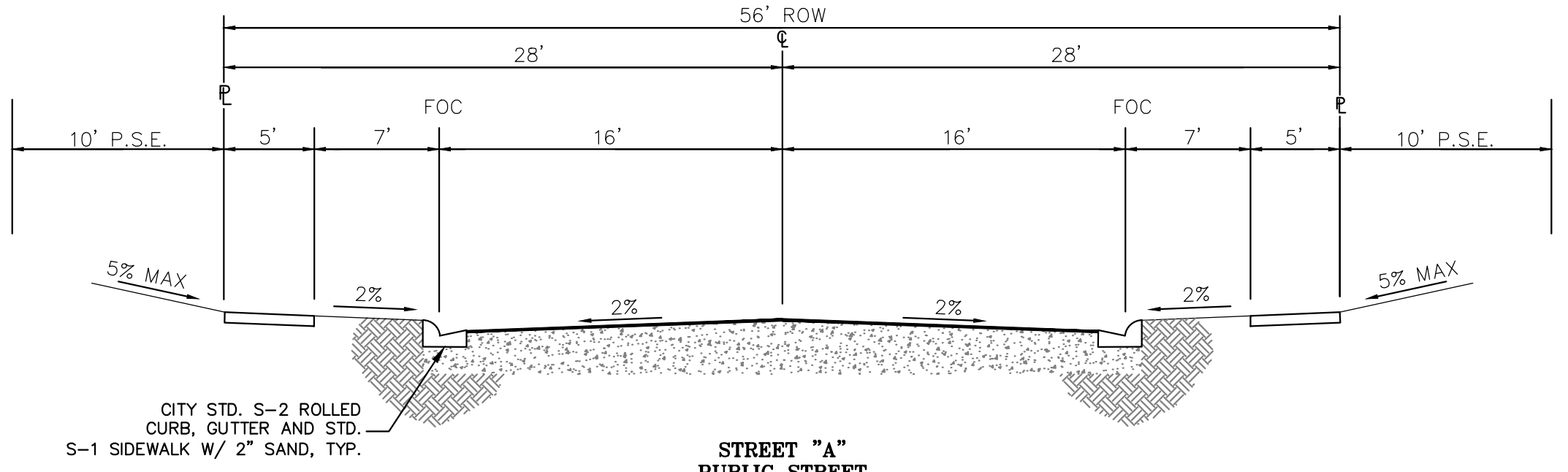

STREET "A" PUBLIC STREET WITH ON-STREET PARKING TYPICAL SECTION

FAITHFUL ESTATES SUBDIVISION
VESTING TENTATIVE SUBDIVISION MAP S/PDP 16-04
(A PUBLIC STREET SUBDIVISION)

for
THE KITE GROUP

BEING A DIVISION OF PARCEL A1 OF BOUNDARY LINE MODIFICATION
14-11 RECORDED IN RSN 2014-0042591
CITY OF CHICO, COUNTY OF BUTTE
STATE OF CALIFORNIA

W. GILBERT ENGINEERING
140 YELLOWSTONE DRIVE, SUITE 110
CHICO, CALIFORNIA 95973
(530) 809-1315

OPEN SPACE CALCULATIONS:

1) GROSS SUBDIVISION AREA = 2.221 ACRES± = 96,747 SF
LANDSCAPED AND USEABLE OPEN SPACE AREA = 35,918 SF > 24,187 (25%)

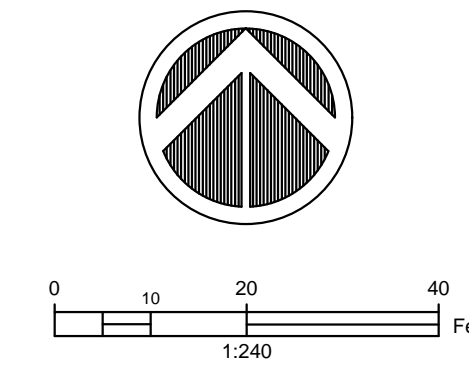

RECEIVED
Feb 14, 2017
City of Chico
Planning Services

PLANNED DEVELOPMENT SITE PLAN

FAITHFUL ESTATES SUBDIVISION

VESTING TENTATIVE SUBDIVISION MAP S/PDP 16-04
(A PUBLIC STREET SUBDIVISION)

for
THE KITE GROUP

BEING A DIVISION OF PARCEL A1 OF BOUNDARY LINE MODIFICATION
14-11 RECORDED IN RSN 2014-0042591
CITY OF CHICO, COUNTY OF BUTTE
STATE OF CALIFORNIA

W. GILBERT ENGINEERING
140 YELLOWSTONE DRIVE, SUITE 110
CHICO, CALIFORNIA 95973
(530) 809-1315

JANUARY 10, 2017

SHEET 1 OF 1

ATTACHMENT E

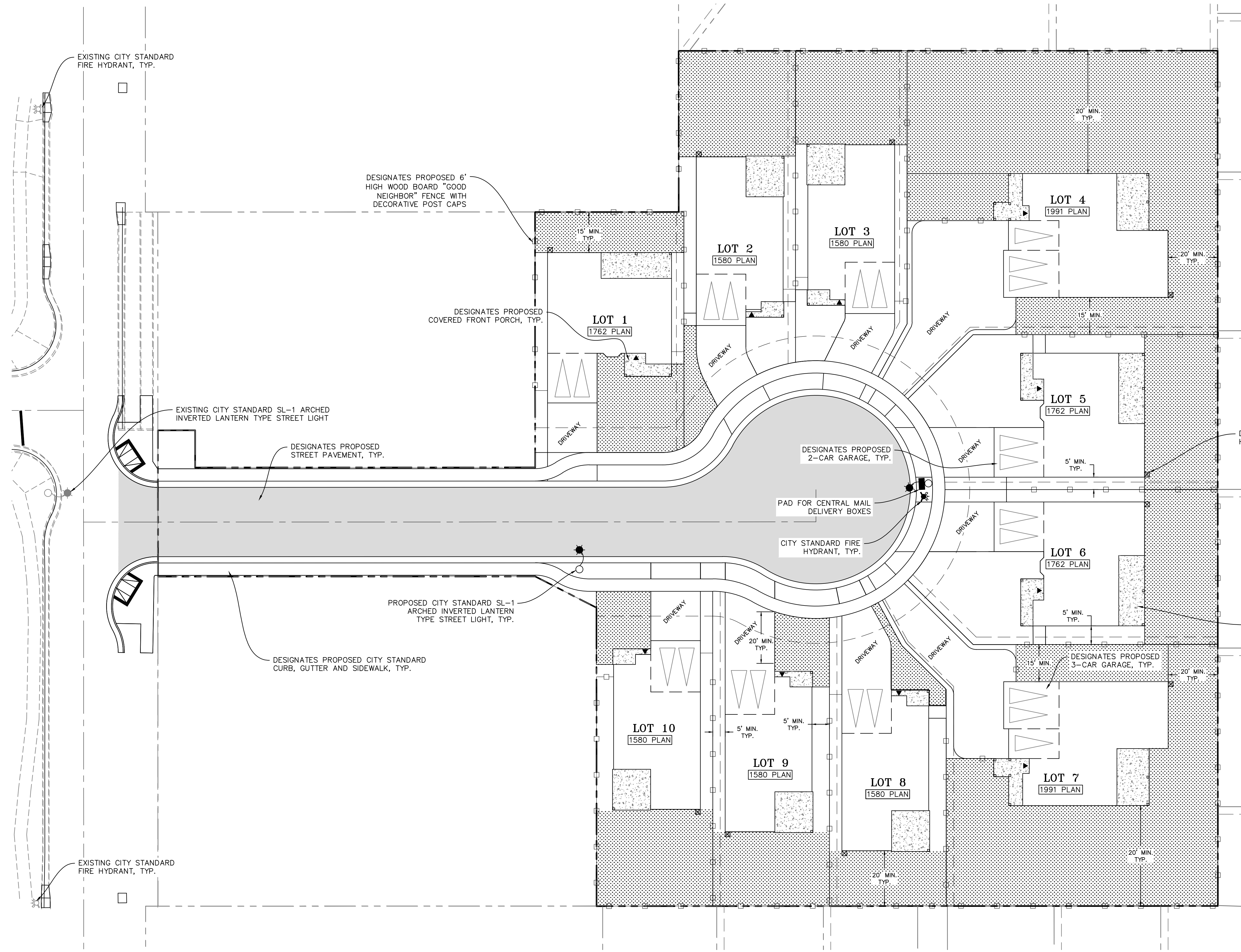

DESIGNATES PROPOSED CITY STANDARD CURB, GUTTER AND SIDEWALK, TYP.

PROPOSED CITY STANDARD SL-1 ARCHED INVERTED LANTERN TYPE STREET LIGHT, TYP.

EXISTING CITY STANDARD SL-1 ARCHED INVERTED LANTERN TYPE STREET LIGHT

DESIGNATES PROPOSED STREET PAVEMENT, TYP.

DESIGNATES PROPOSED 6' HIGH WOOD BOARD "GOOD NEIGHBOR" FENCE WITH DECORATIVE POST CAPS

DESIGNATES PROPOSED COVERED FRONT PORCH, TYP.

DESIGNATES PROPOSED 2-CAR GARAGE, TYP.

PAD FOR CENTRAL MAIL DELIVERY BOXES

CITY STANDARD FIRE HYDRANT, TYP.

DESIGNATES PROPOSED HVAC CONDENSER UNITS, TYP.

DESIGNATES PROPOSED COVERED PATIO, TYP.

DESIGNATES PROPOSED 3-CAR GARAGE, TYP.

1580 PLAN

RECEIVED

NOV 28 2016

CITY OF CHICO
PLANNING SERVICES



LEFT ELEVATION

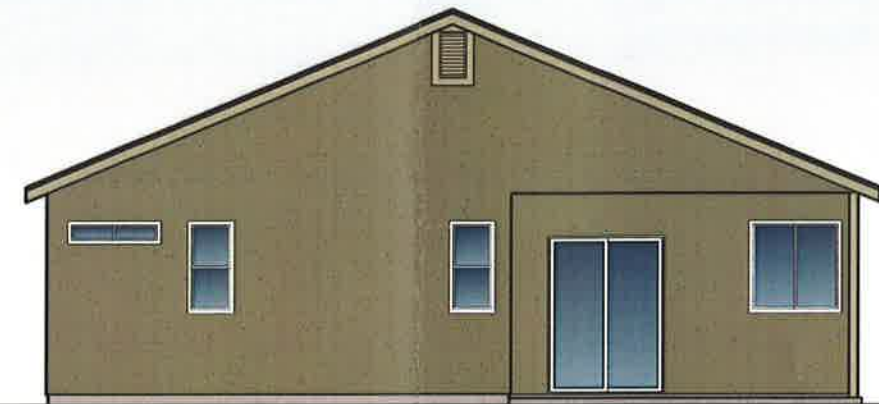

REAR ELEVATION



RIGHT ELEVATION



FRONT ELEVATION

ATTACHMENT F

1762 PLAN

RECEIVED

NOV 28 2016

CITY OF CHICO
PLANNING SERVICES



LEFT ELEVATION



REAR ELEVATION

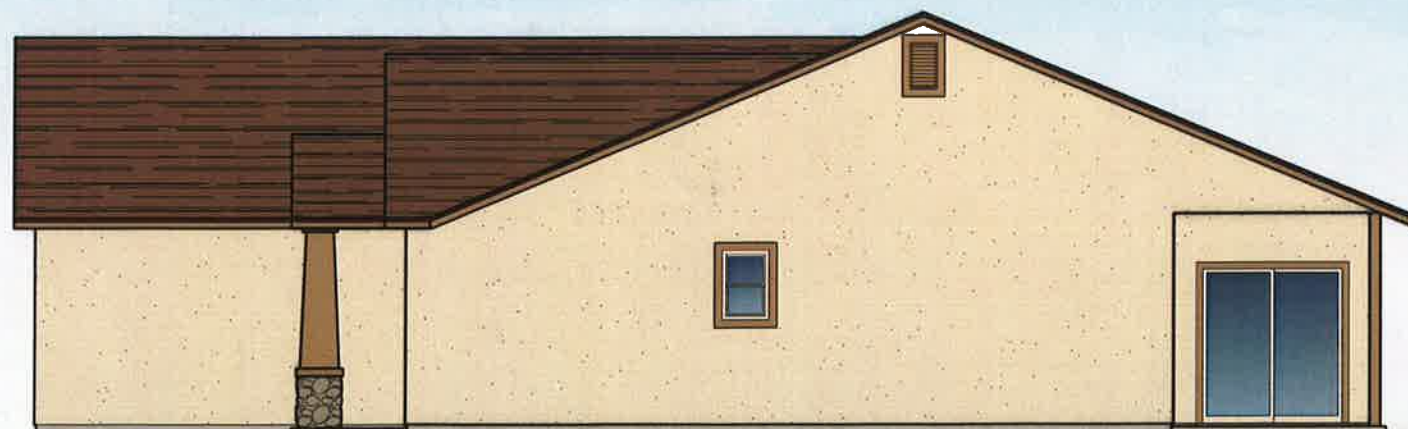

RIGHT ELEVATION



FRONT ELEVATION

ATTACHMENT F

RECEIVED

NOV 28 2016

CITY OF CHICO
PLANNING SERVICES



LEFT SIDE ELEVATION



REAR ELEVATION



RIGHT SIDE ELEVATION

PLAN 1991



FRONT ELEVATION



RECEIVED

Stucco *Examples*

NOV 28 2016

CITY OF CHICO
PLANNING SERVICES

BAY RIDGE

MORNING SIDE

MESA VERDE

BLUE GREY

CORAL GABLES

SOUTHERN MOSS

Faithful Estates

Attachment G





RECEIVED

Stone Examples

NOV 28 2016

CITY OF CHICO
PLANNING SERVICES



SAN FRANCISCO
COBBLEFIELD



CHARDONNAY
COUNTRY LEDGESTONE



BLACK RUNDLE
LEDGESTONE



SUEDE
DRYSTACK LEDGESTONE



ECHO RIDGE
PRO FIT LEDGESTONE



HUDSON BAY
COUNTRY LEDGESTONE

Faithful Estates

Attachment G





Trim Paint *Examples*

RECEIVED

NOV 28 2016

CITY OF CHICO
PLANNING SERVICES

ALABASTER
7008

CARRIAGE DOOR
7594

DRIED THYME
6186

INKWELL
6992

PEPPERCORN
7674

SMOKEHOUSE
7040

Faithful Estates

Attachment G





RECEIVED

Garage Examples

NOV 28 2016

CITY OF CHICO
PLANNING SERVICES



Faithful Estates

Attachment H





Lighting Examples

RECEIVED

NOV 28 2016

CITY OF CHICO
PLANNING SERVICES



Faithful Estates

Attachment I



RECEIVED
 Nov 28, 2016
 City of Chico
 Planning Services

Symbol	Type	Container Size
	Crape Mertle	15 GAL
	Valley Oak	15 GAL
	Red Creeping Thyme	1 GAL
	Red Flax	1 GAL
	Rock River Bed	2in—.5 in
	Fringe Flower	5 GAL
	Germander	1 GAL
	Bark	Medium

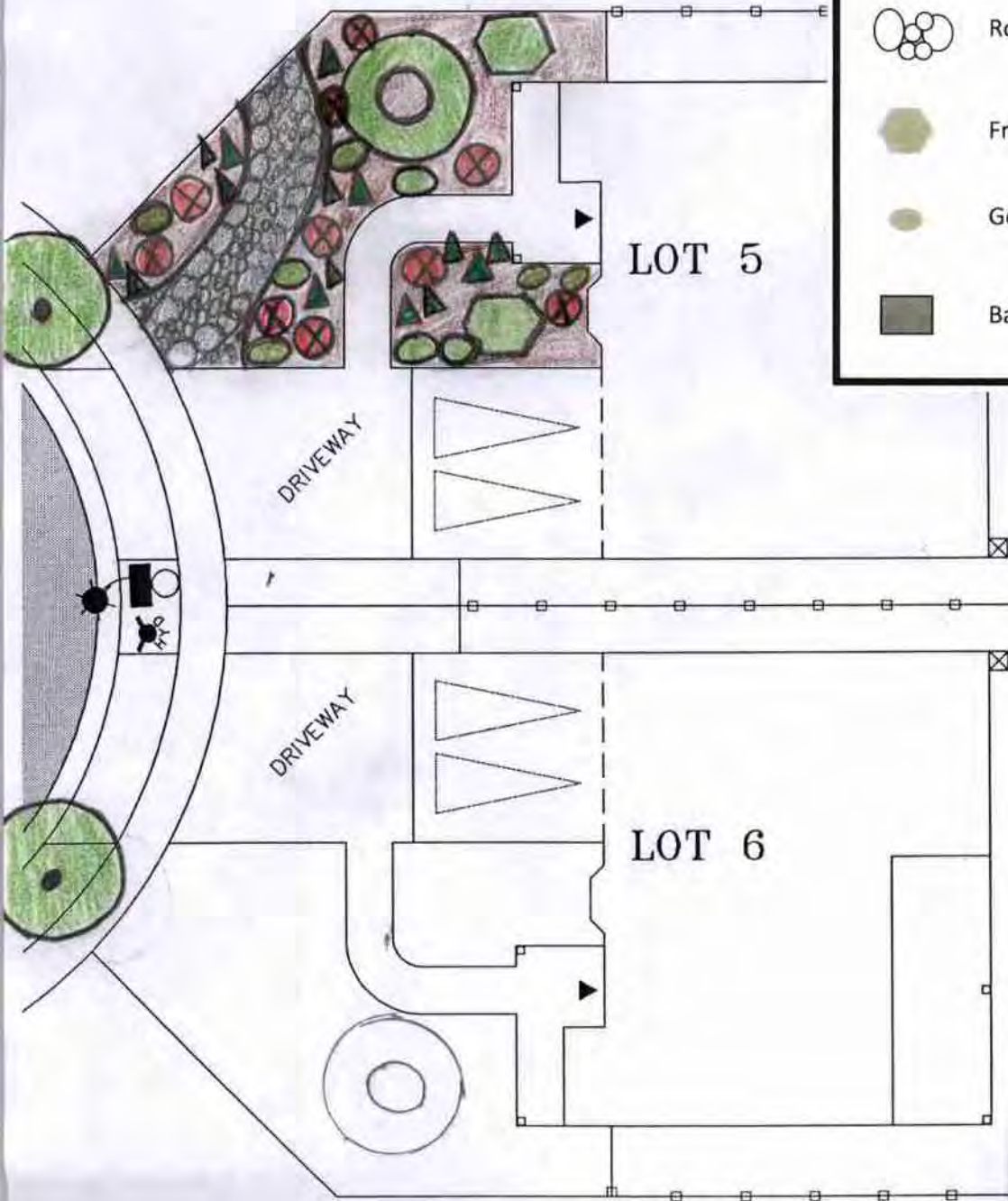

Attachment J

PRELIMINARY LANDSCAPE PLAN
 FAITHFUL ESTATES SUBDIVISION
 VESTING TENTATIVE SUBDIVISION MAP (S/PDP 18-04)
 (A PUBLIC STREET SUBDIVISION)
 for
 THE KITE GROUP
 BEING A DIVISION OF PARCEL A1 OF BOUNDARY LINE MODIFICATION
 14-11 RECORDED IN RSN 2014-0042591
 CITY OF CHICO, COUNTY OF BUTTE
 STATE OF CALIFORNIA

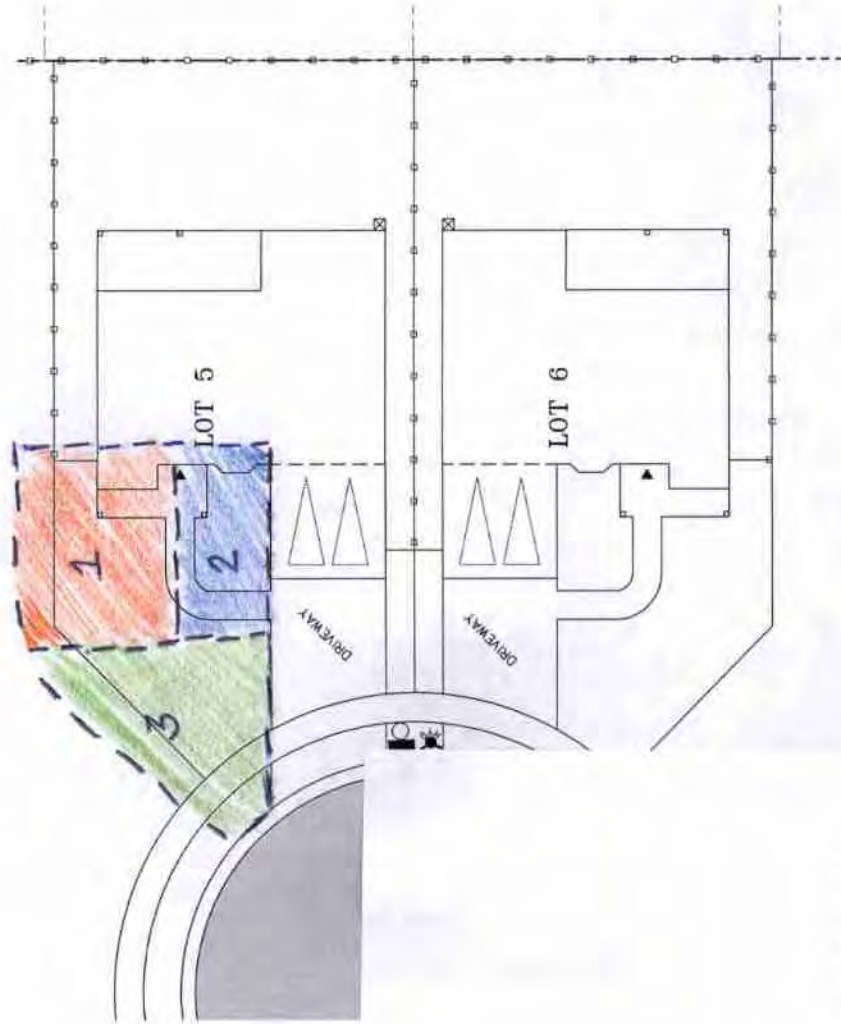

HYDROZONES

- 1. 
- 2. 
- 3. 

NOTES

- Drip irrigation equipment will be in zone 1, 2 & 3 to help conserve water.
- Right of Way areas will be irrigated and planted appropriately according to Assembly Bill 1881.
- If buyer chooses to use spray irrigation no sprinkler heads will be within 2 feet of any impervious surface.

RECEIVED
Nov 28, 2016
City of Chico
Planning Services

PRELIMINARY LANDSCAPE PLAN
FAITHFUL ESTATES SUBDIVISION
VESTING TENTATIVE SUBDIVISION MAP (S/PDF 16-04)
(A PUBLIC STREET SUBDIVISION)

THE KITE GROUP
for
BENIG A. DIVISION OF PARCEL A1 OF BOUNDARY LINE MODIFICATION
14-11 RECORDED IN RSM 2014-0042561
CITY OF CHICO, COUNTY OF BUTTE
STATE OF CALIFORNIA