



# Architectural Review and Historic Preservation Board Agenda Report

Meeting Date 06/20/2018

DATE: June 11, 2018

File: AR 18-04

TO: Architectural Review and Historic Preservation Board

FROM: Kimber Gutierrez, Associate Planner, (879-6810, kimber.gutierrez@chicoca.gov)  
Community Development Department

RE: McGuire Apartments, 632 Cedar Street; APN 004-206-002, -008, and -011  
New multi-family housing development

## RECOMMENDATION

Staff recommends that the Architectural Review and Historic Preservation Board adopt the required findings contained in the agenda report and approve the proposed project, subject to the recommended conditions.

### Proposed Motion

I move that the Architectural Review and Historic Preservation Board adopt the required findings contained in the agenda report and approve Architectural Review 18-04 (McGuire Apartments), subject to the recommended conditions.

## BACKGROUND AND PROPOSED PROJECT

The applicant proposes to construct a multi-family housing development on a 0.9 gross acre (0.6 net acre) site on the west side of Cedar Street between West 6<sup>th</sup> Street and West 7<sup>th</sup> Street (see **Attachment A**, Location Map). The site is designated Commercial Mixed-Use (CMU) on the City's General Plan Land Use Diagram and is zoned CC (Community Commercial) with –COS (South Campus Corridor Opportunity Site) and –FS (Fraternity and Sorority) overlays.

On May 10, 2018, the Map Advisory Committee approved a Certificate of Merger authorizing the merging of three existing parcels to become one parcel and on June 12, 2018, the Zoning Administrator approved Use Permit 18-03 authorizing ground floor residential occupancy in the CC zoning district and a reduction in required off-street parking.

The proposed project involves demolition of the existing on-site structures and construction of a new 20-unit multi-family housing development (see **Attachment B**, Project Description). The development includes four new buildings each containing five, three-story townhouse-style units with first floor garages and living space above. Each unit would feature a second story porch balcony. The site design situates the four buildings into rows, with the side of the buildings and two new entrance drives facing Cedar Street (see **Attachment C**, Site Plan). Each set of buildings share a common driveway and two vehicle parking spaces would be provided for each unit within private garages. The two interior buildings would have their front entries facing each other with a common pedestrian walkway connecting to the Cedar Street public right-of-way. A six-foot wood fence would be constructed along the rear (west) property line to create a physical separation between the existing commercial development and the proposed residential development (see **Attachment D**, Fence Detail).

The building's exteriors would feature stucco surfaces with decorative metal siding elements which would project out to create covered entry's and break up the flat roofline (see **Attachment E**, Renderings). The metal siding colors would alternate among units with every other unit having Rustic Red or Old Zinc Gray (see **Attachment F**, Color Board). Besides the metal siding colors the front elevations would have Rustic Red front doors with Weathered Copper and Fallbrook stucco on the first floor, with Eggshell stucco on the second and third floor exteriors (see **Attachment G**, Elevations). The rear elevations feature Eggshell stucco walls, accented with a strip of Weathered Copper stucco, as well as, Rustic Red metal siding and garage doors. The balconies would be covered with Old Zinc Gray colored metal siding and would be located in between the metal siding features. Wide window trims featured on all windows would be painted grey (Fallbrook). Wall sconces are proposed over each garage door, can-lights are proposed in the ceilings of the front porches, and bollard lights are proposed throughout the common walkway (see **Attachment H**, Lighting Specifications). A concrete masonry trash enclosure with matching stucco finish and ribbed metal doors is proposed at the end of each drive aisle (**Attachment C**).

New landscaping is proposed around the perimeter of the site, within the drive aisles and throughout the common walkway (see **Attachment I**, Landscape Plan). Several types of trees, shrubs, vines and groundcovers are proposed as part of the proposed development. Tall narrow tree plantings are proposed in the central driveway aisles to break up the building canyon in addition to building exterior offsets. The landscaping plan indicates one black walnut tree and one oak tree to be removed from the site. Parking lot shading is provided by the first floor garages. Gas meters would be located on the Cedar Street elevation, screened from view by the proposed landscaping.

The project was approved for a parking reduction through the use permit process. The project site is within the South Campus Corridor Opportunity Site overlay zone and therefore meets the first parking reduction criterion outlined in Chico Municipal Code (CMC) § 19.70.050(A). The proposed parking reduction would not likely overburden public parking supplies in the project vicinity as there is ample vacant and underutilized on-street parking available adjacent to the site on Cedar Street and West 7th Street. Indoor bicycle storage is proposed within the garage of each unit and guest bicycle parking would be located at the entrance of the common walkway (**Attachment I**).

## **DISCUSSION**

### Setbacks

The proposed plan meets all applicable setbacks set forth in the Community Commercial zoning district. Pursuant to CMC §19.44.030, Table 4-7, no setbacks are required in the CC zoning district, except where the block is partly within or abutting a Residential zoning district, in which case varying setbacks are required. The proposed site design includes a three foot setback from the Cedar Street property line, four foot setback from the West 7<sup>th</sup> Street property line, four foot setback from the rear (west) property line, and 10 foot setback from the side (north) property line. Since the proposed project is solely a residential project in a commercial corridor, medium high density residential (R3 zoning district) setbacks would be more appropriate. The City is pursuing an update Title 19 of the CMC to apply residential setbacks for solely residential projects within a commercial zoning district; however, these code changes have not been approved and are not in effect.

### Landscaping

The proposed landscape plan was reviewed by the City's Urban Forest Manager who recommends replacing the "Tree Green elm" with Princeton American Elm (*Ulmus americana* 'Princeton') as this will lower potential sidewalk damage. Therefore, staff has included a condition of approval (Condition No. 5) requesting this change.

### Lighting

As stated, wall sconces are proposed over each garage door, can-lights are proposed in the ceilings of the front porches, and bollard lights are proposed throughout the common walkway (**Attachment H**). Light specifications are provided; however, the site plan, landscape plan, or elevations do not specify the locations of the proposed bollard lights. Staff has included a condition (Condition No. 6) to ensure that project lighting will meet CMC §19.60.050 (*Exterior Lighting*).

The proposal creates a very prominent street presence with its high density, three story height and shallow setbacks. The townhouse style units create an efficient living space placing required parking inside ground-level garages with living areas above. A pedestrian-friendly streetscape is emphasized by use of balconies and covered entry porches along the front elevation. Cantilevered masses on the north and south elevations reduce a flat appearance, as do the balconies and front porches along the front elevation.

The project is consistent with several General Plan goals and policies, including those that encourage compatible infill development (LU-1, LU-4, and CD-5) and providing adequate supply of rental housing to meet a wide range of renters and future needs throughout the city (H.3, H.3.2, and H.3.4). The placement of the building on the site is consistent with policies that encourage orientating multi-family housing developments and front entries to the street (DG 4.1.13 and 4.1.35). Ground-floor entries and second-story porches help to define the individual dwelling units (DG 4.2.11 and 4.2.41).

The parking area is located to the interior of the site, providing vehicle visibility to residents while reducing views of automobiles from the public street (DGs 1.1.14, 4.1.52, and 4.1.53).

## **REQUIRED FINDINGS FOR APPROVAL**

### Environmental Review

The project has been determined to be categorically exempt pursuant to the California Environmental Quality Act (CEQA) Guidelines §15332 (In-Fill Development Projects). Consistent with this exemption, the project is: consistent with the applicable general plan designation, zoning regulations, and general plan policies; is less than five acres in size; substantially surrounded by urban uses; has no habitat value for special status species; will not result in any significant impacts regarding traffic, noise, air quality, or water quality; and can be adequately served by all required utilities and public services.

### Architectural Review

According to the Chico Municipal Code Section 19.18.060, the Architectural Review and Historic Preservation Board shall determine whether or not a project adequately meets adopted City standards and design guidelines, based upon the following findings:

1. *The proposed development is consistent with the General Plan, any applicable specific plan, and any applicable neighborhood or area plans.*

The proposal is consistent with several General Plan policies. The three-story design is consistent with surrounding development, achieving compatible infill development (LU-4.2 and LU-4.3), and context-sensitive design (CD-5.2 and CD-5.3). The site is not located within the bounds of a Neighborhood Plan or area plan.

2. *The proposed development, including the character, scale, and quality of design are consistent with the purpose/intent of this chapter and any adopted design guidelines.*

The placement of the building on the site is consistent with policies that encourage orientating multi-family housing developments and front entries to the street (DG 4.1.13 and 4.1.35). Ground-floor entries and second-story porches help to define the individual dwelling units (DG 4.2.11 and 4.2.41).

The parking area is located to the interior of the site, providing vehicle visibility to residents while reducing views of automobiles from the public street (DGs 1.1.14, 4.1.52, and 4.1.53).

3. *The architectural design of structures, including all elevations, materials and colors are visually compatible with surrounding development. Design elements, including screening of equipment, exterior lighting, signs, and awnings, have been incorporated into the project to further ensure its compatibility with the character and uses of adjacent development.*

The design, material selection and color pallet of the proposed structures are visually compatible with the surrounding residential development. Wall-mounted utilities would be hidden from view, and the trash area would be appropriately screened (DG 3.1.35). Bicycle parking facilities are located within private garages and close to the buildings entrance, consistent with DG 3.1.34. The parking lot features appropriate lighting that would limit unnecessary glare impacts on residents or neighboring properties (DG 4.1.44).

4. *The location and configuration of structures are compatible with their sites and with surrounding sites and structures, and do not unnecessarily block views from other structures or dominate their surroundings.*

The project configuration would not result in incompatibilities with existing nearby and adjacent residential and commercial uses. The building's placement along the street frontage would dominate the streetscape of the adjacent pedestrian environment. The adjacent parcel towards the north side is approved for three-story multi-family residential development; therefore, the structures overall height will not unnecessarily block views or dominate its surroundings.

5. *The general landscape design, including the color, location, size, texture, type, and coverage of plant materials, and provisions for irrigation and maintenance, and protection of landscape elements, have been considered to ensure visual relief, to complement structures, and to provide an attractive environment.*

The proposed landscaping will provide visual relief around the site perimeter, softening the building's proximity to Cedar Street and West 7<sup>th</sup> Street. Tree and plant species have been thoughtfully and appropriately selected for their locations and the variety of plant types will provide color, texture and coverage to the overall project. Tall narrow tree plantings are proposed in the central driveway aisles to break up the building canyon in addition to building exterior offsets.

### **RECOMMENDED CONDITIONS OF APPROVAL**

1. The front page of all approved building plans shall note in bold type face that the project shall comply with Architectural Review 18-04 (McGuire Apartments). No building permits related to this approval shall receive final approval without authorization of Community Development Department Planning staff.
2. All development shall comply with all other State and local Code provisions, including those of the City of Chico Community Development and Public Works Departments. The permittee is responsible for contacting these offices to verify the need for compliance.
3. All wall-mounted utilities and roof or wall penetrations, including vent stacks, utility boxes, exhaust vents, gas meters and similar equipment, shall be screened by appropriate materials and colors. Adequate screening shall be verified by planning staff prior to issuance of a certificate of occupancy.
4. All new electric, telephone, and other wiring conduits for utilities shall be placed underground in compliance with CMC 19.60.120.
5. The developer shall substitute Princeton American Elm (*Ulmus americana* 'Princeton') for the proposed True Green Elm (*Ulmus parvifolia*).
6. Prior to occupancy, the applicant shall coordinate with Planning staff to conduct a site visit to ensure all elements of the site plan have been executed, including, but not limited to shielded exterior lighting consistent with CMC 19.60.050 (*Exterior lighting*).

### **PUBLIC CONTACT**

Public notice requirements are fulfilled by placing a notice on the project site and by posting of the agenda at least 10 days prior to the ARHPB meeting.

### **ATTACHMENTS**

- A. Location Map
- B. Project Description
- C. Site Plan
- D. Fence Detail
- E. Renderings
- F. Color Board
- G. Elevations
- H. Lighting Specifications

I. Landscape Plan

**DISTRIBUTION**

Internal (3)

Mike Sawley, Senior Planner

Kimber Gutierrez, Associate Planner

Files: AR 18-04

External (2)

Greg Peitz, Email: [gregpeitz@sbcglobal.net](mailto:gregpeitz@sbcglobal.net)

Bill McGuire, Email: [hobie99@sbcglobal.net](mailto:hobie99@sbcglobal.net)

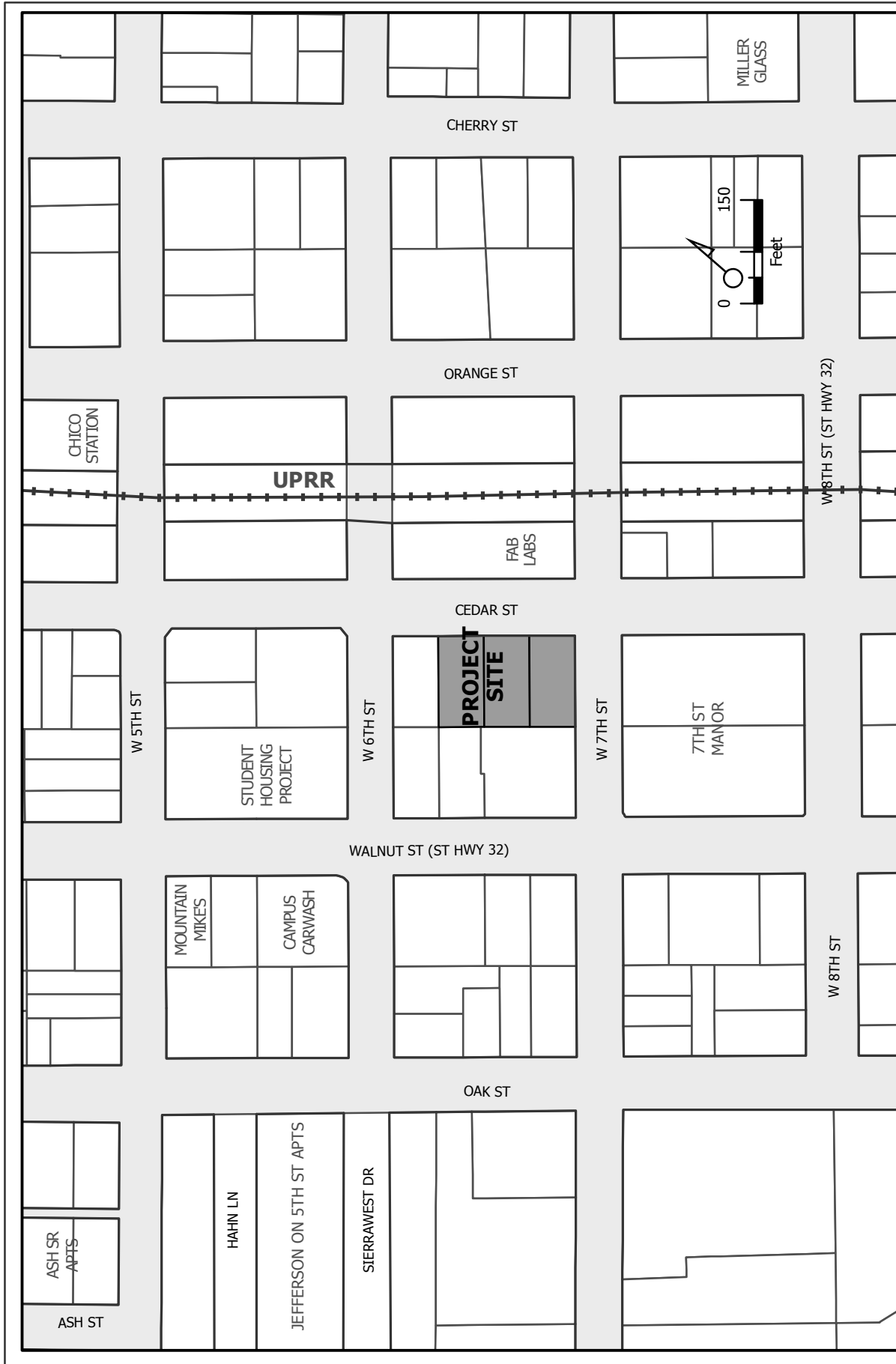

AR 18-04 (McGuire)  
 632 Cedar Street  
 APNs 002-206-(002, 008, 011)-000

# GREGORY A. PEITZ ARCHITECT

383 RIO LINDO AVENUE, CHICO CA 95926 (530) 894-5719

April 24, 2018

RECEIVED

APR 24 2018

CITY OF CHICO  
PLANNING SERVICES

**SUBJECT: MCGUIRE APARTMENTS  
ARHPB PROJECT DESCRIPTION**

The McGuire Apartments is a twenty unit student oriented apartment complex of three story townhouses. It's architectural objective is to create a unique and interesting environment for the students using modern geometric shapes with vibrant colors. It's functional objective is to provide a comfortable, safe living environment with indoor car parking, indoor bicycle parking and all living and sleeping spaces on the second and third floors.

Each apartment has an individual covered front entry at ground level surrounded by attractive landscaping to give each unit a row house type of identity and a pleasant and inviting front entrance. (DG 4.1.13, 4.1.35)

Three colors of stucco in combination with two types of metal siding with two alternating colors are used to provide variation in the exterior textures and colors. Vibrant colors are used to accentuate the different geometric shapes of the buildings. (DG 4.1.15, 4.2.31)

Each has a ground level front porch which connects directly to the on-street parking and public sidewalks making each unit pedestrian friendly and easily accessible both for the tenants and their guests. (DG 4.1.52, 4.1.35, 4.1.12)

Car parking is provided with a two car garage for each unit which are all accessed from the rear of the building. This allows the cars and garages to not be the main visual element from the street. (DG 4.1.12, 1.1.14, 4.1.61)

While garage parking provides 100% shade for the car spaces, 50% shade produced by shade trees is still required for the access aisle. Per CMC 19.70.060.E, 2(d), this requirement may be waived by the ARHPB if the proposed design provides a solution "of greater quality or community benefit." We feel that the proposed design meets this standard for the following reasons:



1. Tucking the parking under the apartment provides more secure parking while providing visual relief from the normal car-dominated landscape of a conventional parking lot.
2. Tucking the parking under the apartment minimizes the exposed paving, thereby reducing the heat build-up and rainwater run-off.
3. Shading the drive aisle with trees requires that the buildings be moved apart approximately 10' to accommodate the trees while still providing the required drive aisle width for the cars. This approach creates significantly more paving, which is a negative for the reasons already mentioned.
4. Three story buildings straddling a drive aisle as proposed provides significantly more shade than a conventional, tree shaded lot. During a large percentage of the day, the entire drive aisle will be shaded by the buildings.
5. The sides of the drive aisle are provided with landscape peninsulas containing compact and columnar plant species that will lend the softening effect desired without requiring the widening of the driveway.

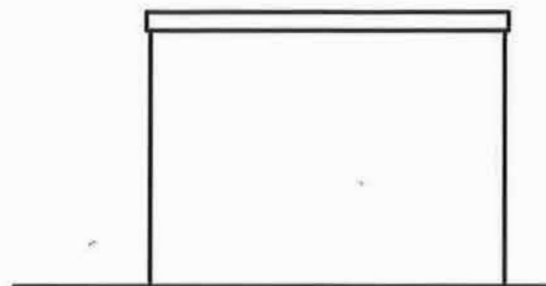

ELEVATION VIEW (FROM SIDE)  
NOT TO SCALE

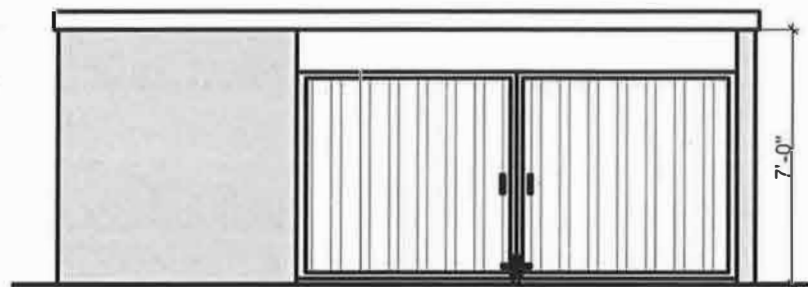

ELEVATION VIEW (FROM FRONT)  
NOT TO SCALE

**TRASH ENCLOSURE LEGEND:**

CONCRETE MASONRY UNIT WALLS WITH STUCCO FINISH. COLOR AND TEXTURE TO MATCH BUILDING FIELD COLOR.

RIBBED, EXPANDED METAL DOORS INSET WITHIN 2" X 2" HOLLOW STRUCTURAL STEEL (HSS) FRAME, AND DROP BOLT ASSEMBLY. COLOR TO MATCH BUILDINGS TRIM.

SLUMP CAP (COLOR AND FINISH TO MATCH CMU TRASH ENCLOSURE WALLS)

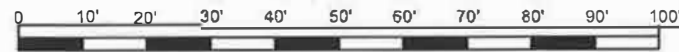

**PROJECT SPECIFICATIONS:**

302 CEDAR STREET  
APN: 004-206-002, 004-206-008, 004-206-011  
GENERAL PLAN: CMU  
ZONE: CC

**SETBACKS:**

FRONT:	0'-0"
SIDES:	0'-0"
REAR:	0'-0"

**PARKING:**

PARKING REQ'D:	RESIDENTIAL (2 SPACES PER UNIT)
	(20) UNITS x (2) SPACES PER UNIT = 40 SPACES REQ.
PARKING PROVIDED:	40 SPACES
BICYCLE SPACES REQ'D:	10% OF VEHICLE SPACES REQ'D. = 4 SPACE
BICYCLE SPACES PROVIDED:	(4) SPACES

**LANDSCAPE:**

MIN. SITE LANDSCAPE OPEN SPACE:	5% MIN.
LANDSCAPE OPEN SPACE PROVIDED:	23.2%

**LOT COVERAGE:**

MAXIMUM LOT COVERAGE:	95% MAX.
ACTUAL LOT COVERAGE:	49.4%

**PARKING LOT LANDSCAPING:**

PARKING AREA:	6,574 SQ. FT.
PARKING LOT LANDSCAPING AREA:	352 SQ. FT.
PARKING LOT LANDSCAPING REQUIRED:	5.0%
PARKING LOT LANDSCAPING PROVIDED:	5.4%

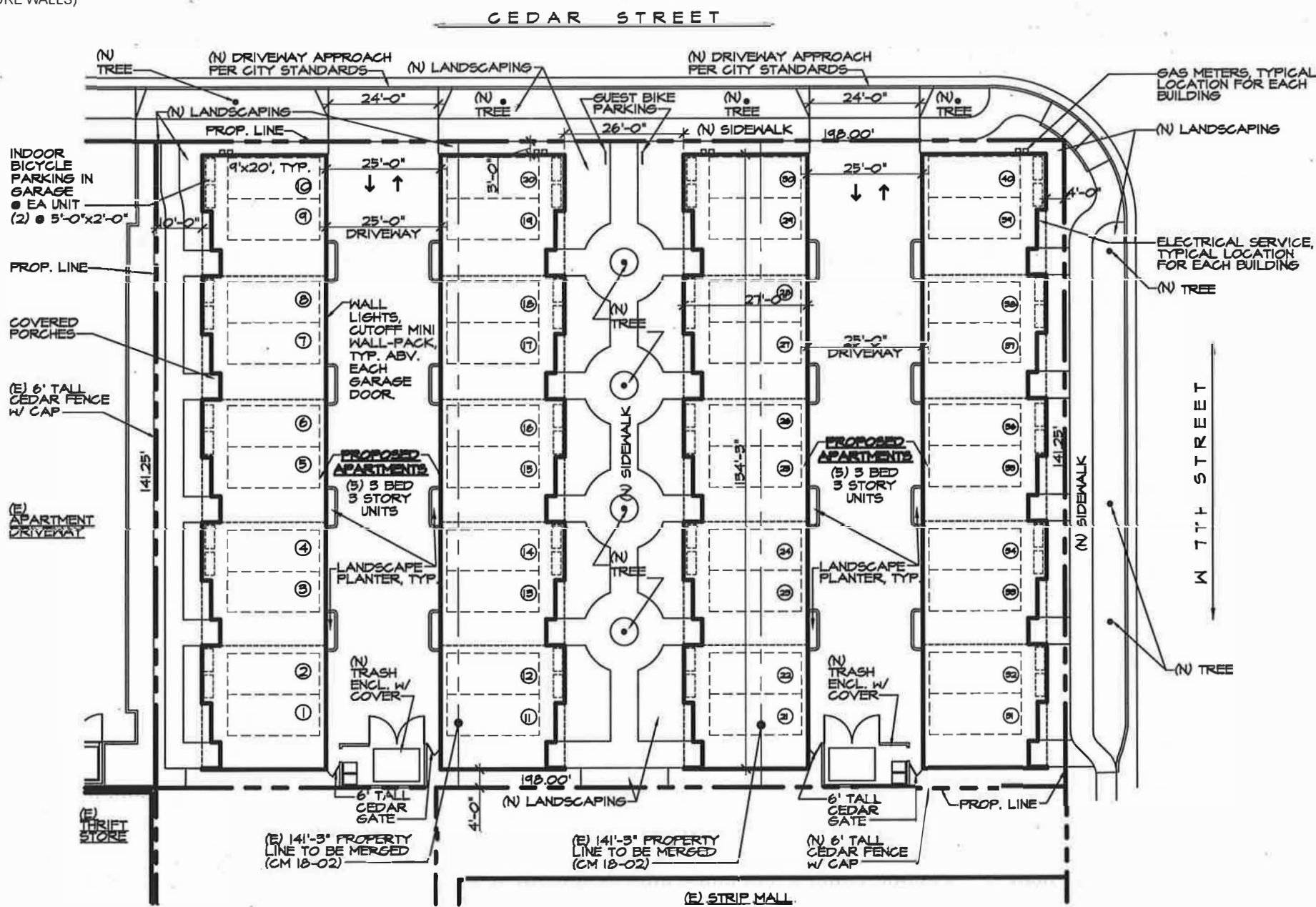

**SITE PLAN**

1" = 50'-0"

REF. NORTH NORTH



**LIGHTING:**

BUILDING: CAN LIGHTS @ COVID PATIOS  
PARKING: CUTOFF MINI WALL-PACKS, ABOVE GARAGE DR.

ATTACHMENT 'C'

Revision	Date	By

GREGORY A. PEITZ  
ARCHITECT

38 3Rto LinderoA vs. C Hco. C.A. 9 9 26 (5 30)8 94-5719

5- PLEX (3 BEDROOM UNITS)  
FOR: BILL MCGUIRE  
AT: 632 CEDAR ST.  
CHICO, CALIFORNIA

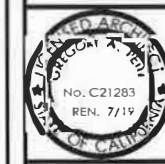

MCGUIRE  
5- PLEX  
TOWNHOMES

Date: APRIL 2018

Scale:

Drawn:

Job: 17-2303

Sheet:

ARB1

**PRIVACY FENCING ILLUSTRATION**

McGUIRE TOWN HOUSES  
APPLICATION FOR ARCHITECTURAL REVIEW

WOOD MATERIAL -> WHITE-WOOD w/ STAINED FINISH

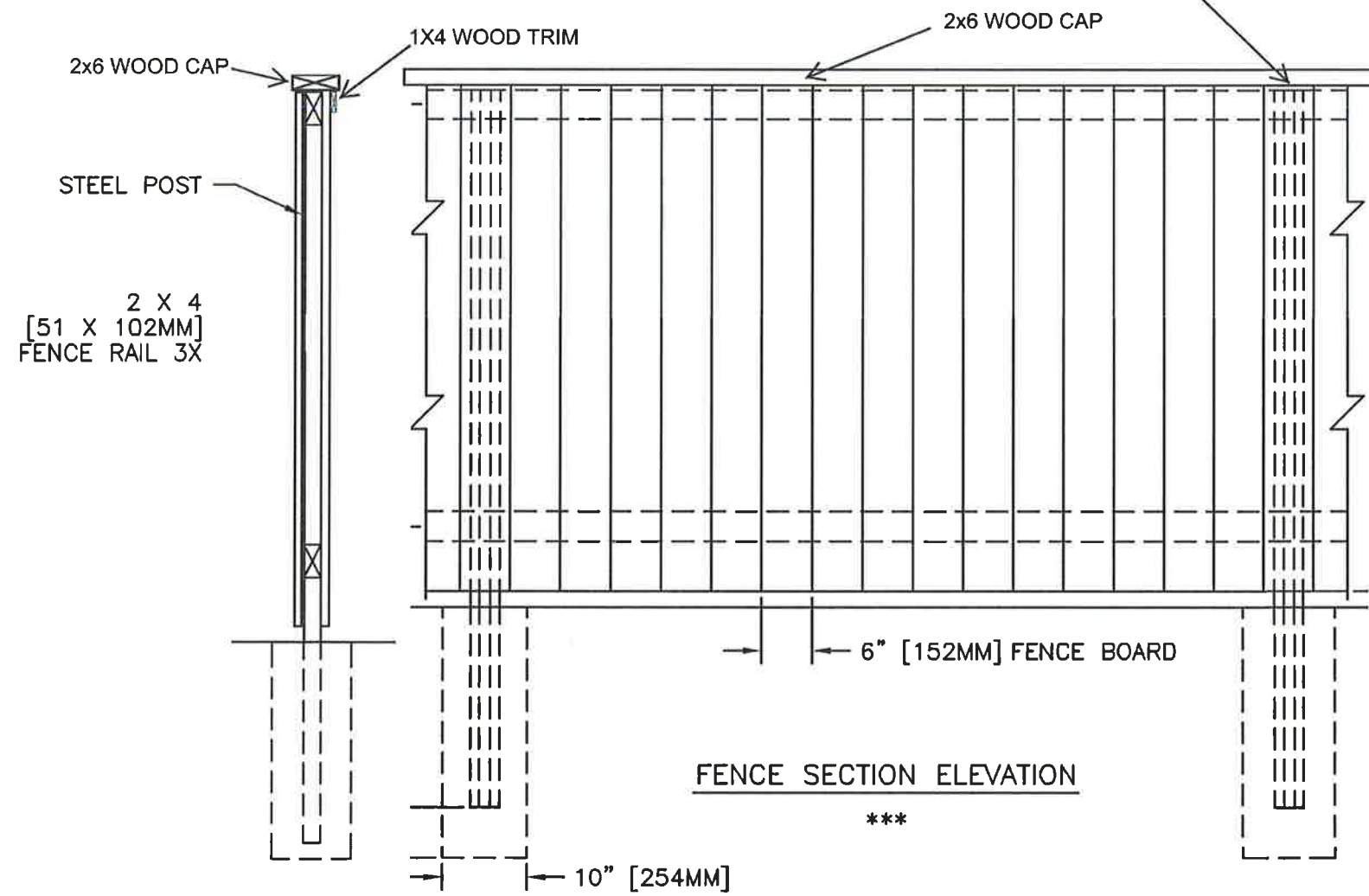
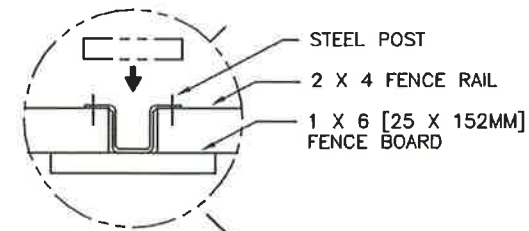















# BILL MCGUIRE

## 5-PLEX BUILDINGS



UPPER STUCCO -  
'LA HABRA' - 73 EGGSHELL

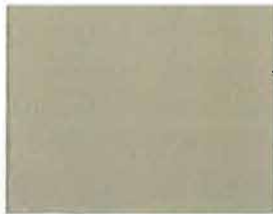

MIDDLE STUCCO & WINDOW FRAMES-  
'LA HABRA' - 434 FALLBROOK



LOWER STUCCO, ACCENTS - 'ASC  
BUILDING PRODUCTS' - WEATHERED  
COPPER



DOORS & METAL SIDING-  
'ASC BUILDING PRODUCTS' - RUSTIC RED



METAL SIDING & STANDING SEAM METAL  
ROOFING - 'ASC BUILDING PRODUCTS' -  
OLD ZINC GRAY





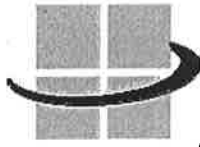

# AccessFixtures

www.AccessFixtures.com Sales@AccessFixtures.com 888.521.2582

## Round Dome Top Bollard w/ Louvers BOL3

Round Dome Top Bollard w/ Louvers

Extruded aluminum dome top bollard with powdercoat finish, louver reflector, and clear polycarbonate lens. Housing features a flush mounting base, vandal resistant screws, and an internal ballast tray.

**Housing:** Extruded aluminum housing with flush mounting base & vandal-resistant screws, dome top, powdercoat finish over a chromate conversion coating, internal ballast tray for easy maintenance

**Refractor:** Louvers

**Lens:** Clear Polycarbonate Lens

**Socket:** Porcelain 4KV Pulse Rated Medium Base

Socket w/ Nickel Plated Screw Shell (HID)

Plug-in Type GX24Q-4 (PL)

**Lumens (Initial):** 2250-9500

**Mounting:** Mounting Kit with 8" Anchor Bolts (Included)

**Wattage:** 35 to 100 High Pressure Sodium, 70 to 100 Metal Halide, 42 to 57 Fluorescent

**Voltage:** 120/208/240/277(HPS & MH) 120-277(PL)

**Listing & Ratings:** CSA: Listed for Wet Locations

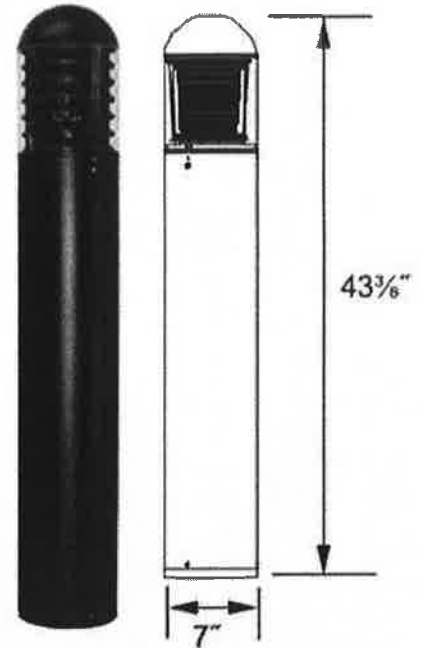

- Other Wattages & Custom Colors Available
- Upon Request, Bollards Can Be Cut To Custom Heights

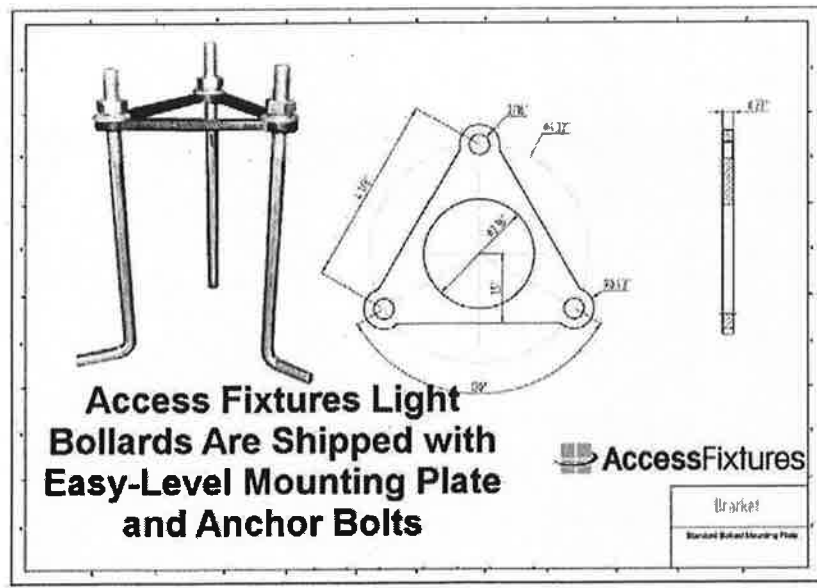

**PATRIOT WALL SCNCE** (Various reflectors are protected by U.S. Patent No. 6,464,378.)



Flat-lensed fixtures meet IESNA full cutoff classification

**DIMENSIONS**

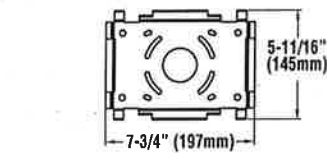
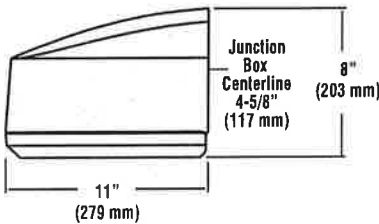
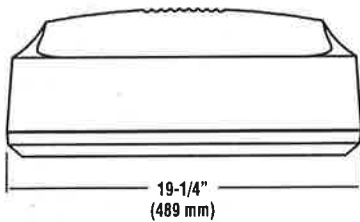

Universal Mounting Plate

**HOUSING** - The one-piece die-cast aluminum housing is a multi-radiused rectangular shape. All mounting hardware is stainless steel or electro-zinc plated steel.

**WALL MOUNT** - A galvanized-steel universal wall mounting plate easily mounts directly to a 4" octagonal or square junction box. An EPDM gasket is supplied to be installed between the mounting plate and junction box, sealing the junction box from entrance of water. The galvanized-steel universal plate allows the fixture to be suspended while making wiring connections. A unique clamping design securely locks the fixture to the wall mounting plate by utilizing two hex head screws. The universal plate permits the fixture to be mounted in the uplighting or downlighting position. Both positions are listed for wet locations. The standard housing/door seal design prevents external contaminants from entering the PTWS, resulting in an IP65 rating.

**DOOR FRAME** - The die-cast aluminum door frame with two black stainless steel captive fasteners allows easy access into the fixture. A one piece extruded silicone closed-cell sponge gasket seals the door frame against the housing. The door hinges open for ease of lamp and ballast maintenance.

**LENS/GASKET** - A flat clear tempered glass lens is sealed to the door frame with silicone closed-cell sponge gasketing.

**SOCKETS** - HID lampholders are glazed porcelain, medium base, 4KV pulse rated. The Compact Fluorescent fixtures feature a one-piece thermoplastic socket.

**LIGHT SOURCES** - The fixture is designed to operate with horizontal Ceramic Metal Halide, Metal Halide, High Pressure Sodium, and single or double Compact Fluorescent lamps. Lamps supplied as standard – HID (clear, shipped installed), and Compact Fluorescent (coated, 4100K, not installed).

**BALLASTS/ELECTRICAL COMPONENTS**

- Electrical components are factory-mounted in housing and prewired with voltage specific leads which extend out the back of the unit through a rubber grommet. This grommet prevents the entry of insects, dust, and moisture into the fixture. The need to open the fixture to make wiring connections is eliminated, thus making installation quick and easy. UL listed HID components with high-power factor ballasts rated for -20° F starting. Compact Fluorescent ballasts are Electronic Universal Voltage (120-277V, 50/60Hz) or 347V (60Hz), 0° F starting. Compact Fluorescent fixtures with UE (Universal Electronic) voltage are available with an optional dimming ballast for multiple types of controls such as building lighting controls and occupancy sensors. Available battery back-up of BB (32° starting temperature) and CWBB (0° starting temperature) are 120 or 277 voltage specific for U.S. applications for 26 watt through 42 watt lamps. Consult factory for available wattages and voltages for use in Canada

**EMERGENCY OPERATION** - A variety of integral emergency options are available to comply with Life Safety Codes which require emergency lighting along the path of egress on the building's exterior, so building occupants can exit safely. Integral Emergency Battery Back-up options are available on Compact Fluorescent units. Emergency Quartz options are offered on HID units. Options for one or two 12 volt separate circuit(s), for use with up to 35 watt Halogen lamp(s) are available on both Compact Fluorescent and HID units.

**REFLECTORS/DISTRIBUTION PATTERNS**

- Forward Throw (FTM, FT), Type III (3), and Wall Wash (WW) reflectors are available. All are high performance, full cut-off distribution as defined by the IESNA (downlight position only). Photometric data is tested in accordance with IESNA guidelines.

**FINISHES** - Each fixture is finished with LSI's DuraGrip® polyester-powder finishing process. The DuraGrip finish withstands extreme weather changes without cracking or peeling and is guaranteed for five full years. Standard colors include bronze, black, platinum plus, white, satin verde green, metallic silver, and graphite.

**PHOTOMETRICS** - Please visit our web site at [www.lsi-industries.com](http://www.lsi-industries.com) for detailed photometric data.

SHIPPING WEIGHTS - Patriot Wall Sconce				
Catalog Number	Est. Weight (kg/lbs.)	Length (mm/in.)	Width (mm/in.)	Height (mm/in.)
PTWS-HID	11/25	616/24.25	394/15.5	362/14.25
PTWS-CFL	9/20	616/24.25	394/15.5	362/14.25



IP65



Project Name \_\_\_\_\_ Fixture Type \_\_\_\_\_  
 Catalog # \_\_\_\_\_

10/22/15

# PATRIOT WALL SCNCE

## LUMINAIRE ORDERING INFORMATION



TYPICAL ORDER EXAMPLE: **PTWS FTM 42 CFL2 F UE BRZ BB**

Luminaire Prefix	Distribution	Lamp Wattage	Light Source	Lens	Line Voltage	Luminaire Finish	Options
PTWS	3 - Type III FT - Forward Throw WW - Wall Wash	50 70 100 150	CMH - Ceramic Metal Halide 150 Watt MH - Metal Halide 70, 100 <sup>1</sup> , 150 Watt HPS - High Pressure Sodium 50 <sup>2</sup> , 70, 100, 150 Watt	F - Flat Clear Tempered Glass	120 208 240 277 347 480	BRZ - Bronze BLK - Black PLP - Platinum Plus WHT - White SVG - Satin Verde Green GPT - Graphite MSV - Metallic Silver	PCI120 - Button-Type Photocell PCI208 - Button-Type Photocell PCI240 - Button-Type Photocell PCI277 - Button-Type Photocell PCI347 - Button-Type Photocell DIM - CFL Control Voltage Dimming Ballast <sup>4</sup> C - Coated MH Lamp SQT - Stand-by Quartz (Time Delay) <sup>5</sup> SQN - Stand-by Quartz (Non Time Delay) <sup>5</sup> EQ - Emergency Quartz (Separate 120V Circuit - HID only) <sup>5</sup> EQ2 - Two Emergency Quartz (2 separate 120V circuits - HID only) <sup>6</sup> BB - CFL Battery Back-up <sup>7</sup> CWBB - CFL Cold Weather Battery Back-up <sup>7</sup> EMR1 - One Emergency 12V Circuit Provision with 35 Watt Halogen Lamp <sup>8</sup> EMR1LL - One Emergency 12V Circuit Provision - Less Halogen Lamp <sup>8</sup> EMR2 - Two Emergency 12V Circuit Provisions with (2) 35 Watt Halogen Lamps <sup>8</sup> EMR2LL - Two Emergency 12V Circuit Provisions - Less Halogen Lamps <sup>8</sup> LL - Less Lamp PMA - Pole Mounting Adaptor w/fixture backplate for square poles <sup>9</sup> PMAR - Pole Mounting Adaptor w/fixture backplate for round poles <sup>9</sup>
	FTM - Forward Throw Medium	26 32 42 57 70	CFL - Compact Fluorescent Single 26, 32, 42, 57, 70 Watt CFL2 - Compact Fluorescent Double 26, 32, 42 Watt		UE - Universal Electronic (120-277V 50/60Hz)		
	WW - Wall Wash		CFL - Compact Fluorescent Single 26, 32, 42 Watt		347 <sup>3</sup>		

Consult Factory  
for International  
Voltages and Light  
Sources

ACCESSORY ORDERING INFORMATION (Accessories are field installed)		Description	Order Number	Description	Order Number
FK120 - Single Fusing	FK120 <sup>10</sup>	FK347 - Single Fusing	FK347 <sup>10</sup>		
FK277 - Single Fusing	FK277 <sup>10</sup>	PTWS SW BLK - Surface Wiring Box (black only)	356915BLK		
DFK208, 240 - Double Fusing	DFK208, 240 <sup>10</sup>	PTWS PLS - Polycarbonate Shield	244657		
DFK480 - Double Fusing	DFK480 <sup>10</sup>				

### FOOTNOTES:

- 1- Supplied with an HX-HPF transformer as standard. Also available with a 120/277 volt CWA transformer - consult factory.
- 2- 50 watt is not available in 347V.
- 3- 347 volt CFL is not available with dimming ballast (DIM) option or battery back-up options (BB, CWBB).
- 4- CFL Dimming Control by others.
- 5- HID lamp wattages 50 and 70 are supplied with a 50 watt, 120V quartz lamp. HID lamp wattages 100 through 175 are supplied with a 100 watt, 120V quartz lamp. EQ option is not compatible with EMR options.
- 6- Available on 100 watt minimum HID fixtures. HID lamp wattages 100 through 175 are supplied with two 50 watt, 120V quartz lamps. Not compatible with EMR options.
- 7- Battery Back-up available on single and double 26, 32 or 42 watt CFL units with 120 or 277 voltage specific units for U.S. applications. Please change Line Voltage of UE to 120 or 277 when ordering this option. On double units, one lamp will be energized by Battery Back-up. Consult factory for specific Means of Egress job application compliance.
- 8- Utilizes G24 socket(s). 12 volt separate circuit(s) required. Not compatible with EQ, EQ2, PMA or PMAR options.
- 9- For single and D180 mounting configurations only. Not compatible with EQ, EQ2, and all EMR options. Use with 5" traditional drilling pattern.
- 10 - Available on HID fixture only. Fusing to be installed in a compatible junction box supplied by contractor.



Project Name \_\_\_\_\_ Fixture Type \_\_\_\_\_  
 Catalog # \_\_\_\_\_

10/22/15

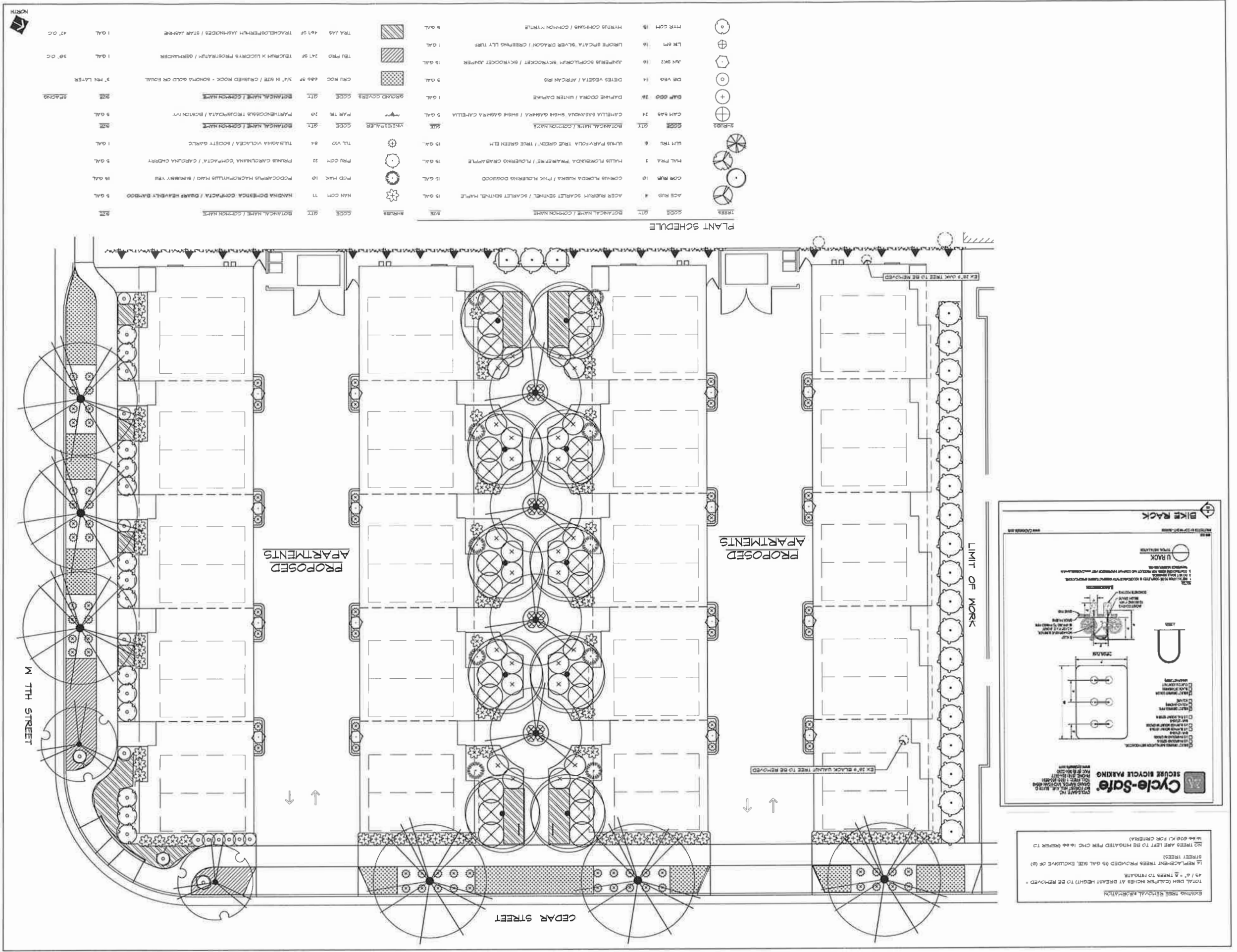

**5-PLEX TOWNHOUSE UNITS  
LANDSCAPE IMPROVEMENT PLANS  
CEDAR STREET  
CHICO, CALIFORNIA**

THOMAS H. PHELPS  
LANDSCAPE ARCHITECTURE

California Landscape Architect #1122  
P.O. Box 8318  
Chico, CA 95921-8318  
(530) 897-0897 fax (530) 897-9588  
thp@thp.com  
THPARCH.COM

PLANTING PLAN

Scale: 1/8" = 1'-0"  
Date: 04/24/18  
Project: THP

**BIKE RACK**

**Secure-Safe**  
SECURE BICYCLE PARKING

**Cycle-Safe**  
SECURE BICYCLE PARKING

**U RACK**

**LIMIT OF WORK**

**APPROVED APARTMENTS**

**PROPOSED APARTMENTS**

**CEAR STREET**

**W 7TH STREET**

EXISTING TREE RECYCLING RELOCATION  
TOTAL DBH (CALIPER INCHES AT BREAST HEIGHT) TO BE REMOVED = 49' 6" 8 TREES TO PLANT  
14 REPLACEMENT TREES PROVIDED (9 GAL SIZE EXCLUSIVE OF (6) STREET TREES)  
NO TREES ARE LEFT TO BE PLANTED PER CHC 16.6 (REFER TO 16.6 (10) K1 FOR DETAILS)

EX 24" BLACK GALVANIZED TREE TO BE REMOVED

EX 24" OAK TREES TO BE REMOVED