



Architectural Review
and Historic Preservation Board
Agenda Report

Meeting Date 08/16/2017

DATE: July 31, 2017

File: AR 17-32

TO: Architectural Review and Historic Preservation Board

FROM: Shannon Costa, Assistant Planner, (879-6807, shannon.costa@chicoca.gov)
Community Development Department

RE: Grove Office Building, 1270 E. 9th Street; APN 004-331-036
New shell building

RECOMMENDATION

Staff recommends that the Architectural Review and Historic Preservation Board adopt the required findings contained in the agenda report and approve the proposed project, subject to the recommended conditions.

Proposed Motion

I move that the Architectural Review and Historic Preservation Board adopt the required findings contained in the agenda report and approve Architectural Review 17-32 (Grove Office Building), subject to the recommended conditions.

BACKGROUND

The applicant proposes to construct a single-story 3,000 sq. ft. office structure on an 8,000-sq. ft. site at 1270 E. 9th Street (see Location Map **Attachment A** and Applicant's Project Description, **Attachment B**). The site is designated Commercial Mixed Use on the City of Chico General Plan Land Use Diagram, and located in the CC (Community Commercial) zoning district.

Currently vacant, the site plan calls for a new parking area located 10-feet back from the front property line with the new office structure behind. Vehicle access would be provided by a centrally-located driveway leading to a 12-space parking area (see **Attachment C**, Architectural Site Plan). The site plan illustrates the orientation of the building, location of the trash enclosure, bicycle parking rack, and landscaping.

Landscaping is planned around the perimeter of the site. Two large water oak trees provide most of the parking lot shading that is estimated to reach fifty-percent at tree maturity (see **Attachment D**, Landscape Plan). Additional accent trees (crepe myrtles and dogwood trees) are proposed in smaller planting areas. Small trees, shrubs, and groundcover are proposed in the parking lot setback area and at various perimeter locations. Additionally, three raised planter beds are proposed at the building's front entry featuring native plants and grasses. Six light poles of unspecified height are proposed around the perimeter of the parking lot (see **Attachment E**, Lighting Standard).

The buildings front façade would feature a mixture of colors and material types. The centralized entryway would feature a large red brick veneer pop-out ("Cultured Stone"), flanked by corrugated copper metal siding ("Metal Sales") and grey board and batten siding ("City Tower"). The lean-to roof style would feature grey composite shingles ("Owens

Corning"). All other building elevations (sides and rear) would feature a light beige stucco (La Habra "Crystal White") (see **Attachment F**, Elevations and **Attachment G**, Colors/Materials). A metal roll-up door is proposed on the front and rear elevations.

DISCUSSION

The design is challenged by several DGs that encourage a pedestrian orientation by locating buildings closer to adjacent streets and parking in less visible locations (DGs 1.1.13, 1.1.14, 1.1.15 and 3.1.25). The building presents a dominant front entry element; however, the design encourages visitors to walk through the parking area to enter the building, resulting in partial consistency with DG 3.1.11. The absence of architectural elements on three sides of the building is inconsistent with DG 3.2.33 which encourages design continuity throughout all elevations. To better achieve consistency with design guidelines, a condition of approval is recommended to add architectural design elements to the northeast and southwest elevations.

The scale and form of the new building would create an appropriate transition from the residential uses to the north, south and west to the offices and commercial uses to the east, as called for by DGs 1.2.13 and 3.2.11. Consistent with DGs 3.2.23, 3.2.28 and 3.1.35, the building entryway would aid wayfinding by creating a sense of focus, wall-mounted utilities would be hidden from view, and the trash storage area would be appropriately screened. Bicycle parking is located close to the building front entry, and the variety of building colors and materials on the front façade provides visual interest (DG 3.1.21 and 3.2.31).

The proposed plan meets all applicable setbacks, parking, and landscaping requirements, and will occupy a long-vacant site on E 9th Street. Staff supports the proposal.

RECOMMENDED ITEMS OF DISCUSSION

Given that the required finding #3 compels the architectural design to be carried around to all four elevations, discuss the need for additional architectural design elements on the northeast and southwest elevations of the building, such as penetrations or additional landscape features. Modify condition of approval #4 as necessary.

Environmental Review

The project has been determined to be categorically exempt under CMC Section 1.40.220 and pursuant to the California Environmental Quality Act (CEQA) Guidelines Section 15332 (In-Fill Development Projects). Consistent with this exemption, the project is: consistent with the applicable general plan designation, zoning regulations, and general plan policies; is less than five acres in size, substantially surrounded by urban uses; has no habitat value for special status species; will not result in any significant impacts regarding traffic, noise, air quality, or water quality; and can be adequately served by all required utilities and public services.

Architectural Review

According to the Chico Municipal Code Section 19.18.060, the Architectural Review and Historic Preservation Board shall determine whether or not a project adequately meets adopted City standards and design guidelines, based upon the following findings:

1. *The proposed development is consistent with the General Plan, any applicable specific plan, and any applicable neighborhood or area plans.*

The proposal is consistent with several General Plan policies, including those that encourage compatible infill development (LU-1, LU-4, and CD-5). The single-story construction is consistent with General Plan policies that encourage compatible infill development (LU-4.2 and LU-4.3), and context-sensitive design (CD-5.2 and CD-5.3). The project also includes low-water use landscaping that will soften the structure and hardscape elements consistent with SUS-4.2. The site is not located within the bounds of a Neighborhood Plan or area plan.

- 2. The proposed development, including the character, scale, and quality of design are consistent with the purpose/intent of this chapter and any adopted design guidelines.*

The project promotes orderly development in that it would occupy a long-vacant parcel in a manner compatible with adjacent residential and commercial uses. The building design and scale would be compatible with the existing neighborhood, consistent with DGs 1.2.11 and 1.2.13. Consistent with DGs 3.2.23, 3.2.28 and 3.1.35, the building entryway would create a sense of focus, wall-mounted utilities would be hidden from view, and the trash area would be appropriately screened. Bicycle parking facilities are located close to the buildings main entrance, consistent with DG 3.1.34.

- 3. The architectural design of structures, including all elevations, materials and colors are visually compatible with surrounding development. Design elements, including screening of equipment, exterior lighting, signs, and awnings, have been incorporated into the project to further ensure its compatibility with the character and uses of adjacent development.*

The design, material selection and color pallet of the proposed office structure are visually compatible with the surrounding residential and commercial office structures. Conditions of approval will ensure architectural design elements are included on all elevations of the structure and parking lot light standards are limited to 12 feet above grade. Exterior equipment will be properly screened by fences, landscaping or painted to match the structures.

- 4. The location and configuration of structures are compatible with their sites and with surrounding sites and structures, and do not unnecessarily block views from other structures or dominate their surroundings.*

The project configuration would not result in incompatibilities with existing adjacent residential and commercial uses. The building's placement toward to the rear of the site is consistent with the neighboring commercial development and nearby residential structures. The structures overall height will not unnecessarily block views or dominate its surroundings.

- 5. The general landscape design, including the color, location, size, texture, type, and coverage of plant materials, and provisions for irrigation and maintenance, and protection of landscape elements, have been considered to ensure visual relief, to complement structures, and to provide an attractive environment.*

The proposed landscaping will provide visual relief around the site perimeter and will

provide adequate parking lot shading. The variety of plantings along the street will buffer the parking area, providing an attractive environment throughout the year.

RECOMMENDED CONDITIONS OF APPROVAL

1. All building plans shall note on the cover sheet that the project shall comply with AR 17-32 (Grove Office Building). No building permits related to this approval shall be finalized without authorization of planning staff.
2. All new exterior lighting shall be full cutoff and directed onsite such that no light shines offsite and luminaires are minimally visible from adjacent properties. Parking lot light fixtures shall not exceed a total height measured from grade of 12 feet.
3. The proposed landscape plan may be modified as necessary to comply with Low Impact Development (LID) requirements, as promulgated under Chico Municipal Code Section 15.50.
4. The applicant shall provide architectural design elements to the northeast and southwest elevation.
5. All wall-mounted utilities and roof or wall penetrations, including vent stacks, utility boxes, exhaust vents, gas meters and similar equipment, shall be screened by appropriate materials and colors. Adequate screening shall be verified by planning staff prior to issuance of a certificate of occupancy.

PUBLIC CONTACT

Public notice requirements are fulfilled by placing a notice on the project site and by posting of the agenda at least 10 days prior to the ARHPB meeting.

ATTACHMENTS

- A. Location Map
- B. Applicant's Project Description
- C. Architectural Site Plan
- D. Landscape Plan (3)
- E. Lighting Standard
- F. Elevations (2)
- G. Colors and Materials

DISTRIBUTION

Internal (3)

Mike Sawley, Senior Planner

Shannon Costa, Assistant Planner

Files: AR 17-32

External (2)

Greg Peitz, 383 Rio Lindo Ave, Chico, CA 95926

Krista Grove, 3151 Canyon Oaks Terrace, Chico, CA 95928

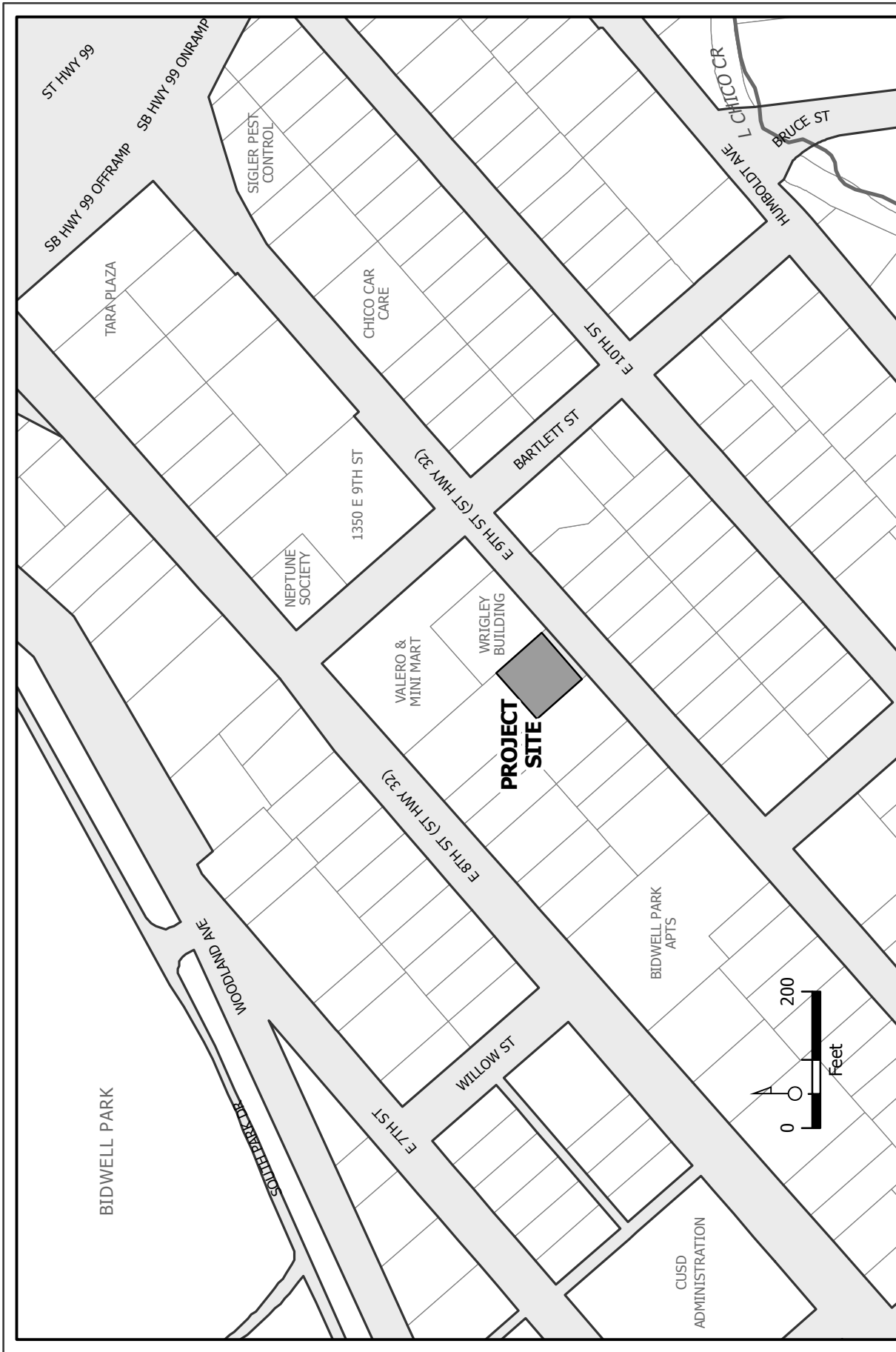

AR 17-32 (Grove Office Building)
 1270 E 9th Street
 APN 004-331-036-000

GREGORY A. PEITZ ARCHITECT

383 RIO LINDO AVENUE, CHICO CA 95926 (530) 894-5719

**Re: Architectural Review
Grove Office Building**

This project is a new professional office building in a mixed use neighborhood with an existing mixture of single and multi-family homes, offices, a car wash and gas station.

The design of the building is intended to blend with the scale and massing of the adjacent buildings and at the same time have some unique shapes and colors to give it a distinct identity. (DG 3.2.11) The building has a mixture of brick, board and batt, corrugated metal and stucco siding to give the building varied textures. These materials all are finished in different colors to draw added attention to the variations of mass and texture. (DG 2.2.32, 2.2.25) The brick sided rectangular element with the metal entrance cover and matching brick raised planters are designed to give identity and draw attention to the main entrance. (DG 2.2.23)

The small size and narrowness of the site make locating the parking in the front the only practical solution. To soften the visual impact of the cars, the parking lot has an ample amount of landscaping, especially surrounding the main driveway entrance. (DG 2.1.25) Through the landscaping is a meandering pedestrian sidewalk connecting the city sidewalk to the main entrance of the building. (DG 2.1.13)

The trash receptacles are located to the side of the property, well screened from view both by a 6' tall masonry enclosure and landscaping. The one mechanical unit is mounted on the ground behind the building, out of public view. (DG 2.1.36)

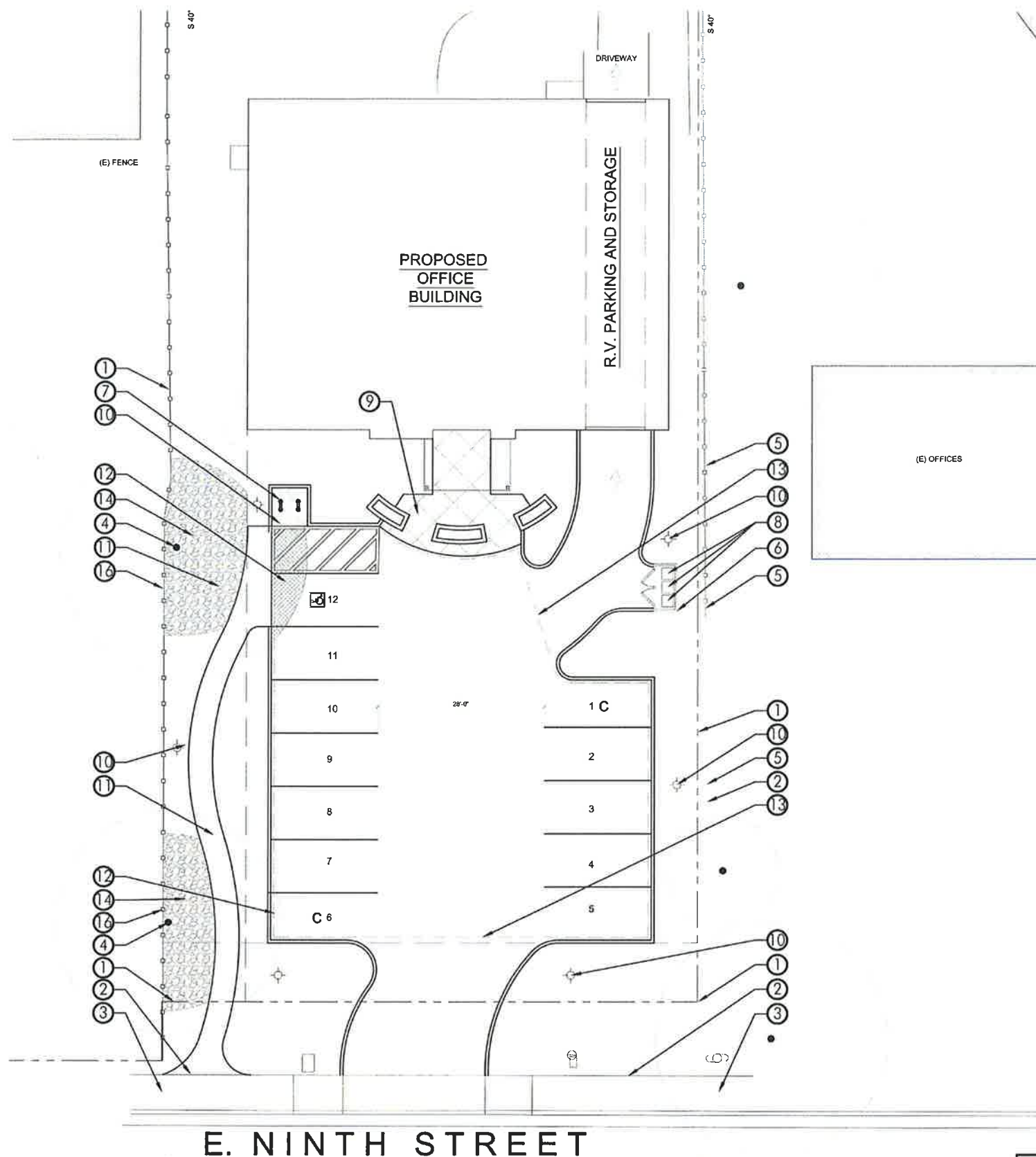

PLAN LEGEND

SYMBOL	DESCRIPTION
①	PROPERTY LINE
②	LIMIT OF WORK
③	EXISTING CITY SIDEWALK.
④	EXISTING VALLEY OAK TREE , TO REMAIN. RETAIN AND PROTECT.
⑤	EXISTING FENCE 6 FOOT HIGH CHAIN LINK WITH SLATS
⑥	TRASH ENCLOSURE (BY OTHERS)
⑦	BICYCLE RACK (4 BIKE CAPACITY). INVERTED 'U' STYLE RACK
⑧	TRASH AND RECYCLING RECEPTACLE
⑨	DECORATIVE CONCRETE
⑩	AREA LIGHT. 12' HIGH SHOEBOX LIGHT WITH GLARE SHROUD CUT OFF.
⑪	CONCRETE PATH
⑫	SHADE FROM EXISTING TREES
⑬	PARKING AND BACKUP AREA
⑭	3" - 6" COBBLE
⑮	36" HIGH RAISED PLANTERS. BRICK WITH CONCRETE CAPS.
⑯	6' HIGH WOOD FENCE WITH 2X6 CAP.

RECEIVED
JUN 14 2017
 CITY OF CHICO
 PLANNING SERVICES

SEE PAGES 2 AND 3 FOR ADDITIONAL INFORMATION

GROVE OFFICE BUILDING (PAGE 1 OF 3) PRELIMINARY LANDSCAPE PLAN

Prepared for:

NEAL AND KRISTA GROVE
 1270 E. 9TH STREET
 CHICO, CALIFORNIA 95928

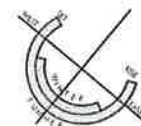

SOLAR INFLUENCE



BAR SCALE



SCALE: 1" = 10'-0"

Prepared by:

BRIAN FIRTH LANDSCAPE ARCHITECT, INC.
 627 BROADWAY, SUITE 220, CHICO, CALIFORNIA 95928
 PHONE: (530) 899-1130/ FAX: (530) 899-1920
 www.BFLAdesign.com www.facebook.com/BFLAdesign

Attachment D

DATE: 6-7-17
 PROJECT NUMBER: 2002
 DRAWN: TDB

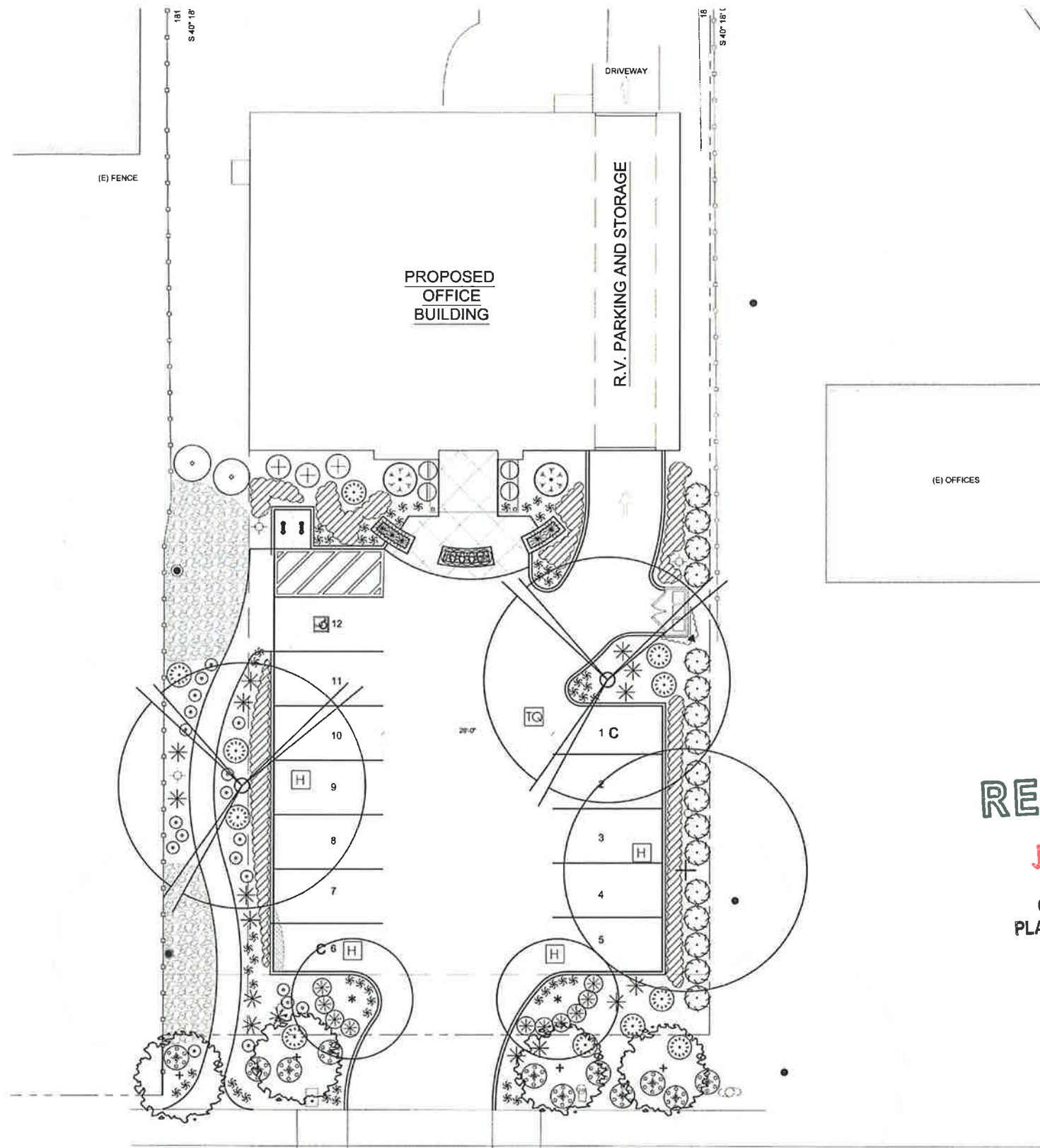

TREE LIST (MEDIUM WATER USE)

SYMBOL	LATIN NAME/ COMMON NAME	SPREAD	CONTAINER SIZE
	ULMUS PARVIFOLIA EVERGREEN ELM	35'	15 GAL
	QUERCUS NIGRA WATER OAK	30'	15 GAL
	LAGERSTROEMIA 'NATCHEZ' WHITE CRAPE MYRTLE	15'	15 GAL
	CORNUS 'EDDIE'S WHITE WONDER' WHITE FLOWERING DOGWOOD	20'	15 GAL
	PICEA PUNGENS 'GLOBOSA' COLORADO SPRUCE	3'	1 GAL

SHRUB LIST (LOW OR MEDIUM WATER USE)

SYMBOL	LATIN NAME/ COMMON NAME	SPREAD	CONTAINER SIZE
	EUONYMUS ALATA 'COMPACTUS' BURNING BUSH	8"	1 GAL
	SPIRAEA BUMALDA SPIRAEA	4"	1 GAL
	MAHONIA AQUIFOLIUM 'COMPACTA' COMPACT OREGON GRAPE	4"	1 GAL
	AQUILEGIA FORMOSA WESTERN COLUMBINE	2"	1 GAL
	PINUS MUGO 'DWARF' DWARF MUGHO PINE	4"	5 GAL
	DIETES 'BICOLOR' DIETES	3"	1 GAL
	ROSA NOATRUM CARPET ROSE	3"	1 GAL
	AGAPANTHUS AFRICANUS LILY OF THE NILE	3"	1 GAL
	TULBAGHIA VIOLACEA 'TRICOLOR' TRI-COLOR SOCIETY GARLIC	2"	1 GAL
	DAPHNE ODORA 'MARGINATA' WINTER DAPHNE	3"	1 GAL
	AZALEA SOUTHERN INDICA 'GEORGE TABOR' PINK AZALEA	4"	1 GAL
	Dwarf Variegated New Zealand Flax DWARF VARIEGATED NEW ZEALAND FLAX	2"	1 GAL
	FICUS PUMILA 'MINIMA' DWARF CREEPING FIG		1 GAL
	ARCTOSTAPHYLOS UVA-URSI 'WOODS COMPACTA' WOODS COMPACT KINNIKINNICK		

RECEIVED

JUN 14 2017

CITY OF CHICO
PLANNING SERVICES

SEE PAGES 1 AND 3 FOR ADDITIONAL
INFORMATION

E. NINTH STREET GROVE OFFICE BUILDING (PAGE 2 OF 3) PRELIMINARY LANDSCAPE PLAN

Prepared for:

NEAL AND KRISTA GROVE
1270 E. 9TH STREET
CHICO, CALIFORNIA 95928



SOLAR INFLUENCE



BAR SCALE



SCALE: 1" = 10'-0"

Prepared by:



BRIAN FIRTH LANDSCAPE ARCHITECT, INC.
627 BROADWAY, SUITE 220, CHICO, CALIFORNIA 95928
PHONE: (530) 899-1130/ FAX: (530) 899-1920
www.BFLAdesign.com www.facebook.com/BFLAdesign

Attachment D

DATE: 6-7-17
PROJECT NUMBER: 2002
DRAWN: TDB

PARKING LOT LANDSCAPE

DESCRIPTION	AREA	PERCENT
PARKING LOT PAVING	3,851 SF	
PARKING LOT LANDSCAPE	194 SF	5.0%

SHADE CALCULATIONS

DESCRIPTION	SHADE AREA	QUANTITY	TOTAL	PERCENT
TOTAL PARKING AND BACK-UP AREA			3,851 SF	
SHADE AREA PROVIDED				
WATER OAK				
F FULL	707 SF	0	--SF	--%
TO THREE QUARTER	530 SF	1	530 SF	14%
H HALF	354 SF	1	354 SF	9%
Q QUARTER	177 SF	0	--SF	--%
			TOTAL 884 SF	23%
ELM				
F FULL	1256 SF	0	--SF	--%
TO THREE QUARTER	942 SF	0	--SF	--%
H HALF	628 SF	1	628 SF	16%
Q QUARTER	314 SF	0	--SF	--%
			TOTAL 628 SF	16%
DOGWOOD				
F FULL	314 SF	0	--SF	--%
TO THREE QUARTER	235 SF	0	--SF	--%
H HALF	157 SF	2	314 SF	8%
Q QUARTER	78 SF	0	--SF	--%
			TOTAL 314 SF	8%
EXISTING TREES				
EXISTING OAK	NA	105	105 SF	3%
			TOTAL 105 SF	3%
TOTAL SHADE AREA PROVIDED			1,931 SF	50%

LANDSCAPE IRRIGATION

TOTAL LANDSCAPED AREA IS 3,521 SF AND IS HYDROZONED AS MEDIUM WATER USE AND SHALL BE IRRIGATED BY MEANS OF AN AUTOMATICALLY CONTROLLED, LOW VOLUME DRIP IRRIGATION SYSTEM.

USING THE WATER BUDGET CALCULATIONS PER AB 1881 REQUIREMENTS, IT HAS BEEN DETERMINED THAT THE ESTIMATED WATER USE (EWU) OF THE PROPOSED LANDSCAPE IS 69,493 GALLONS PER YEAR AND DOES NOT EXCEED THE MAXIMUM APPLIED WATER ALLOWANCE (MAWA), WHICH IS 87,561 GALLONS PER YEAR.

BICYCLE PARKING



VICINITY MAP

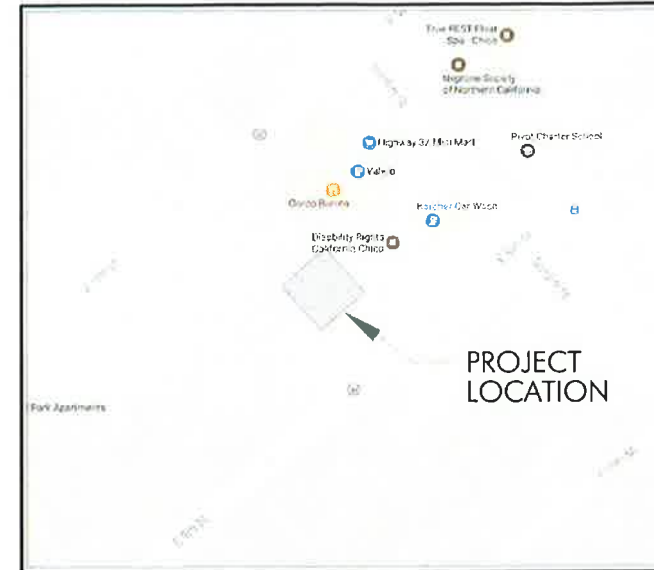

SOILS STATEMENT

THIS SITE IS LOCATED IN A REGION FREE OF TUSCAN FORMATIONS AND LAVA CAPS. SITE SOILS ARE OF SUPERIOR QUALITY. STANDARD SOIL AMENDMENTS WILL BE APPLIED IN ACCORDANCE WITH RECOMMENDATIONS BY AN ANALYTICAL SOILS TESTING LABORATORY.

MULCH

A UNIFORM 2" MINIMUM LAYER OF WALK ON BARK MULCH SHALL BE APPLIED TO ALL LANDSCAPE AREAS EXCEPT WHERE OTHERWISE NOTED.

RECEIVED

JUN 14 2017

ENTRY CONCEPT



SEE PAGES 1 AND 2 FOR ADDITIONAL INFORMATION

GROVE OFFICE BUILDING (PAGE 3 OF 3)

PRELIMINARY LANDSCAPE PLAN

Prepared for:

NEAL AND KRISTA GROVE

1270 E. 9TH STREET
CHICO, CALIFORNIA 95928

DATE: 6-7-17
PROJECT NUMBER: 2002
DRAWN: TDB

Prepared by:

 BRIAN FIRTH LANDSCAPE ARCHITECT, INC.
627 BROADWAY, SUITE 220, CHICO, CALIFORNIA 95928
PHONE: (530) 899-1130 / FAX: (530) 899-1920
www.BFLAdesign.com www.facebook.com/BFLAdesign

Attachment D

LIGHT FIXTURES

ECOLUME QUICK SHIP

In response to increasingly tight delivery schedules, Emco has developed a 3-Day Quick Ship Program that makes it easy to order our most popular and versatile luminaires, poles and options. Lamps for all luminaires are in stock.

When specifying, please pay particular attention to the size of luminaire, wattage and optical system desired. Refer to www.sitelighting.com for the most current information.



RECEIVED

JUN 14 2017

QUICK SHIP AREA LIGHTING LUMINAIRES

CITY OF CHICO
PLANNING SERVICES

Ship From: York, Pennsylvania
Dallas, Texas
San Jose, California

EC14 - Ecolume, 14" square

- 150HPS or 175MH
- Multi-Tap Ballast (120/208/240/277) Tied to 277V
- Bronze Painted (BRP)
- Type 3H or FH (Forward Throw)
- Arm Mount, Wall Mount (no arm), Wall Mount with Arm

PREFIX	MOUNTING	SIZE	CONFIGURATION	DISTRIBUTION	WATTAGE	VOLTAGE	FINISH
EC	A	14	1	3H	175MH	277	BRP
EC	A Arm Mount W Wall Mount WA Wall Mount w/Arm	14	1 2 3 4	3H, FH	150HPS, 175MH	120, 208, 240, 277	BRP = Bronze Paint

EC18 - Ecolume, 18" square

- 250HPS, 400HPS, 250MH or 400MH
- Multi-Tap Ballast (120/208/240/277) Tied to 277V
- Bronze Painted (BRP)
- Type 3H or FH (Forward Throw)
- Arm Mount, Wall Mount (no arm), Wall Mount with Arm

Ship From: York, Pennsylvania
Dallas, Texas
San Jose, California

PREFIX	MOUNTING	SIZE	CONFIGURATION	DISTRIBUTION	WATTAGE	VOLTAGE	FINISH
EC	A	18	1	3H	250MH	277	BRP
EC	A Arm Mount W Wall Mount WA Wall Mount w/Arm	18	1 2 3 4	3H, FH	250HPS, 400HPS, 250MH, 400MH	120, 208, 240, 277	BRP = Bronze Paint

OPTIONS

Add suffix to the end of the order number - **ES**

Example: **EC A 14 1 3V 150HPS 120 BRP ES**

Options:

- AP Adjustable Knuckle - Pole Mount
- AT Adjustable Knuckle - Tenon Mount
- PTF2 Pole Top Filter 2 3/8" diameter (use for use with a 14" - 18" luminaire (2 3/8" X 4"))

STANDARD 'SHOEBOX' STYLE (GARDCO: ECOLUME MODEL: EC A 14 1 3V 150HPS 120 BRP WITH CUTOFF SHROUDS TO ELIMINATE LIGHT SPILLAGE ONTO ADJACENT PROPERTY AND INTO NIGHT SKY).
TYPE OF LAMP: 150 WATT HIGH PRESSURE SODIUM.

RECEIVED

JUN 14 2017

CITY OF CHICO
PLANNING SERVICES



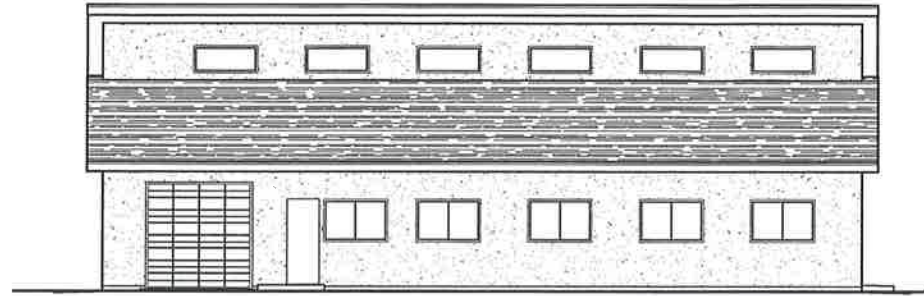

NORTH-WEST ELEVATION

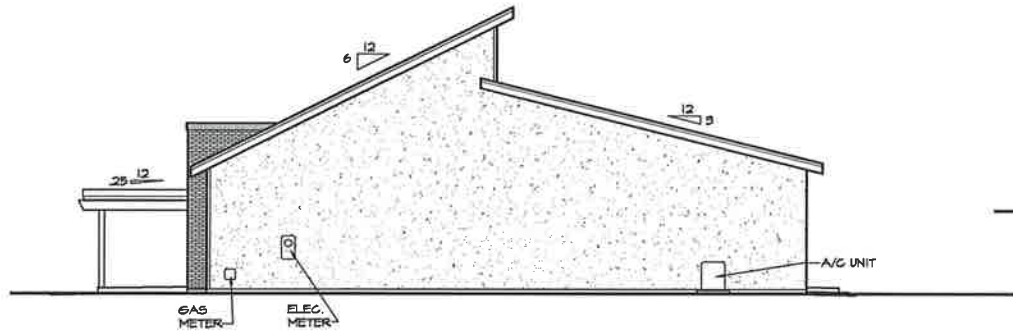

NORTH-EAST ELEVATION

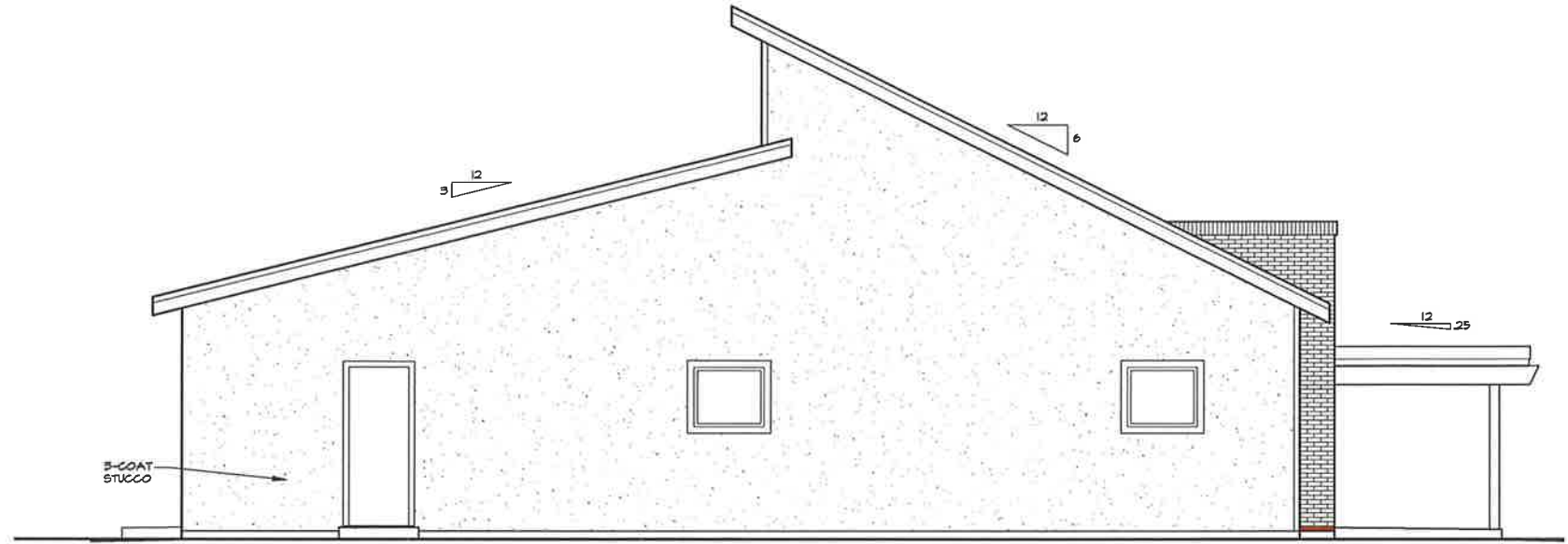

SOUTH-WEST ELEVATION

RECEIVED

JUN 14 2017

**CITY OF CHICO
PLANNING SERVICES**

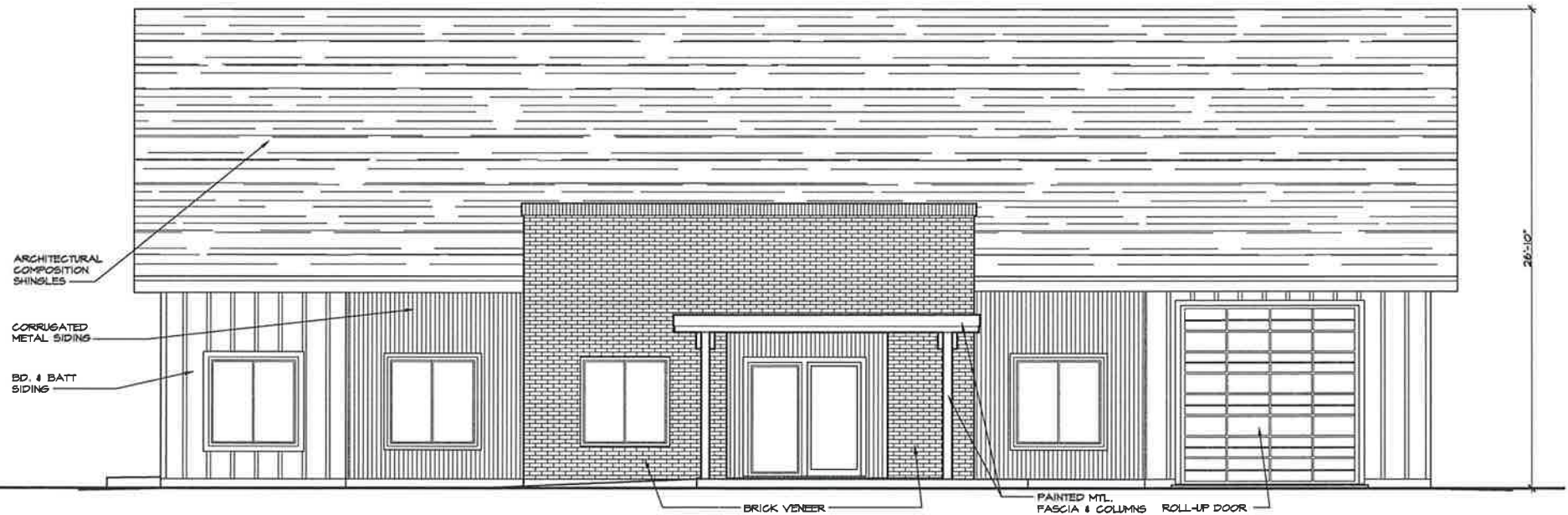

SOUTH-EAST ELEVATION

Revision	Date	By

**GREGORY A. PEITZ
ARCHITECT**
383 Rio Lindo Ave. Chico, CA. 95926 (530) 894-5719
Email: gregpeitz@abglobal.net

For: **Office Building**
Neal and Krista Grove
At: 1270 E. 9th. Street
Chico, California



**GROVE
OFFICE
BUILDING**

Date: **JUNE 2017**
Scale:
Drawn: **DAVID S.**
Job: **17-2271**

Sheet: **ARB-3**
Of: **3** Sheets

GROVE OFFICE BUILDING



STUCCO -
'LA HABRA' - CRYSTAL WHITE 50



BOARD & BATT SIDING -
'KELLY MOORE' CITY TOWER - KM5823



METAL SIDING - 'METAL SALES'
WEATHERED COPPER - W50



STUCCO STONE
'CULTURED STONE'
ANTIQUÉ RED USED BRICK



ROOFING -
COMPOSITION SHINGLES -
'OWENS CORNING'
ESTATES GRAY