



# Architectural Review and Historic Preservation Board Agenda Report

Meeting Date 4/5/17

DATE: March 22, 2017

File: AR 17-05

TO: Architectural Review and Historic Preservation Board

FROM: Mark Corcoran, Senior Planner, (879-6810, mark.corcoran@chicoca.gov)  
Community Development Department

RE: Architectural Review 17-05 (East Avenue Marketplace CSP Modification) – 1380  
East Avenue, APNs 016-060-045, -046, -047, -048, -049, and -050

## REPORT IN BRIEF

The proposed project includes a modification of the existing Comprehensive Sign Program of the East Avenue Marketplace shopping center. The modification would permit the installation of a second center identification sign along the East Avenue street frontage. The CSP includes locations identified by addresses 1350, 1354, 1358, 1366, 1372, and 1380 Nord Avenue.

## RECOMMENDATION

Staff recommends that the Architectural Review and Historic Preservation Board adopt the required findings contained in the agenda report and recommend approval of the modification, subject to conditions.

## Proposed Motion

I move that the Architectural Review and Historic Preservation Board adopt the required findings contained in the agenda report and approve Architectural Review 17-05 (East Avenue Marketplace CSP modification), subject to the recommended conditions therein.

## BACKGROUND

The applicant proposes to amend the existing Comprehensive Sign Program (CSP) of the East Avenue Marketplace shopping center located north of East Avenue and east of Mariposa Avenue (see **Attachment A**). The CSP was originally approved by the Planning Commission on June 26, 2005 as part of Use Permit 05-32. The proposed modification to the CSP would permit the installation of a second center identification sign along the shopping center's East Avenue street frontage. This second center identification sign on East Avenue would also be the third center identification sign for the shopping center.

Following the proposed modification of the CSP, a double-sided 74.59 square foot illuminated sign would be installed at the easterly shopping center driveway from East Avenue (see **Attachment B**). The proposed sign would replace an existing monument sign currently located approximately 25 feet to the west (see **Attachment C**). The site is designated Commercial Mixed Use on the City of Chico General Plan Land Use Diagram, and located in the CC-AOC-PD (Community Commercial- Zone C Airport Operations- Planned Development overlay) zoning district.

All proposed modifications to the existing East Avenue Marketplace CSP are included in **Attachment D** as underlined red text. The proposed modifications include changes to Sections B and C of the CSP which respectively describe the location and design of signs for the shopping center.

The proposed modification of the CSP would be consistent with Section 19.74.070 of the Chico Municipal Code (CMC) which states that a CSP may authorize deviations from the development standards for signs for the zoning district in which and the project is located, except that total maximum sign area allowed by Chapter 19.74 of the CMC shall not otherwise be exceeded. Table 5-8 of CMC Section 19.74.140 states that a multi-tenant shopping center is permitted to have a one center identification sign per street frontage with a maximum sign area not greater than 200 square feet per sign face, or 400 square feet overall. While the proposed modification would result in two center identification signs on the same street frontage, the combined area of the two existing center identification signs and the proposed third center identification sign would equal 447.54 square feet, less than the overall 800 square feet of sign area that the East Avenue Shopping Center could qualify for given that it has two street frontages.

The proposed modification does not include any changes to the sections of the CSP that set criteria for wall signs, under canopy signs, or temporary signs.

## **DISCUSSION**

### Approval Process

Section 19.74.070 of the CMC states that revisions of a CSP that substantially deviate from the original approval shall require an application to modify the CSP. In addition, the code states that a CSP may be approved by the Architectural Review and Historic Preservation Board (Board) for projects that include multiple commercial tenants, or mixed-use projects, developed as a unit on adjacent parcels and located in a commercial zoning district.

### Modifications to the CSP

The purpose of a CSP is to integrate a project's signs with the design of its structures into a unified architectural statement. Additionally, a CSP is intended to provide a means for flexible application of the sign regulations for multi-tenant projects in order to encourage maximum incentives and latitude in the design and display of signs and to achieve, not circumvent, the intent of Chapter 19.74 of the CMC.

As also stated in section 19.74.070 of the CMC, a CSP may authorize deviations from the development standards for the zoning district in which a project is located, except that the total maximum sign area allowed by chapter 19.74 of the CMC shall not be otherwise exceeded.

## **ENVIRONMENTAL REVIEW**

The project has been determined to be categorically exempt pursuant to the California Environmental Quality Act (CEQA) Guidelines Section 15301 (Existing Facilities). Consistent with this exemption, the project would result in a negligible expansion of use beyond that which currently exists.

## **REQUIRED FINDINGS FOR A RECOMMENDATION OF APPROVAL**

### Comprehensive Sign Program

According to CMC Section 19.74.070, the Architectural Review and Historic Preservation Board shall make all of the following findings in addition to those required by Chapter 19.18:

1. *The proposed Comprehensive Sign Program is consistent with the purpose and intent of chapter 19.74 of the Chico Municipal Code.*

The proposed modification to the CSP would allow for the installation of a second center identification sign along East Avenue. The location of the new center identification sign would be consistent with each of the standards for free-standing signs listed in CMC Section 19.74.120.C. Specifically, the location for the new center identification sign: would be located on a frontage adjoining a public street more than 75 feet away from any other freestanding sign; would not be located on any public property, vehicular easement, right-of way, or in an area that would obstruct traffic safety sight lines; and would be surrounded by more than 300 square feet of landscaping.

The additional center identification sign proposed would also be consistent with each of the standards found in CMC Table 5-8 for multi-tenant shopping centers within the CC zoning district, except for the limitation of one center identification sign per street frontage. The new center identification sign would be: less than 100 square feet per sign face with an overall area of less than 400 square feet; less than 20 feet tall, and located more than five feet from the property line such that it would not interrupt vehicular traffic site lines. And while the proposed modification of the CSP would result in more than one center identification sign per street frontage, the overall area of the three center identification signs would be less than the overall maximum area allowed for a shopping center with two street frontages.

Because the proposed modification to the CSP would result in additional signage that is consistent with each of the design standards of Chapter 19.74 of the CMC excepting only the number of signs permitted for street frontage, and the additional signage would not result in an exceedance of the overall maximum signage permitted, the proposed modification would be consistent with the purpose and intent of CMC Chapter 19.74.

2. *The signs are visually related to other signs included in the Comprehensive Sign Program and to the structures and/or developments they identify and to surrounding development.*

The additional center identification sign would be identical in size and design to the two existing center identification signs. The three identical center identification signs would allow visitors to clearly identify the location, boundaries, and tenants of the East Avenue Marketplace shopping center.

3. *The Comprehensive Sign Program complies with all of the standards of Chapter 19.74 of the Chico Municipal Code, including the maximum overall sign area allowable, except that flexibility is allowed with regard to individual sign area, number, location, and/or height to the extent that the Comprehensive Sign Program will enhance the overall development and will more fully accomplish the purposes of Chapter 19.74 of the Chico Municipal Code.*

The proposed modification of the CSP would comply with each of the standards of chapter 19.74 of the CMC for the Community Commercial (CC) zoning district in that the additional center identification sign permitted by the modification would be: ground-mounted; less

than 20 feet in height; located at least five feet from the property line; and outside of any required sight distance area. In addition, the third center identification sign that would be permitted by a modification of the CSP would not result in an exceedance of the maximum overall allowable center identification sign area permitted for a shopping center located within the CC zone.

The modification of the CSP would include an allowance for an additional double-faced center identification sign that would have an area of 74.59 square feet per sign face and an overall total area of 149.18 square feet. Table 5-8 of CMC Section 19.74.140.H states that center identification signs shall have a maximum area of 100 square feet per sign face and a maximum overall total area of 400 square feet. Both of the two existing double-faced center identification signs also have an area of 74.59 square feet per sign face and an overall area of 149.18 square feet. Collectively, the three center identification Signs would have a total area of 447.54 square feet.

Table 5-8 also states that a shopping center within the CC zone is permitted to have one center identification sign per street frontage. The East Avenue Marketplace is therefore permitted to have a total maximum sign area of 800 square dedicated to central identification.

The 447.54 square foot total area of the existing and proposed center identification signs would not exceed the total maximum sign area of 800 square feet for center identification signs identified by Table 5-8 of Chapter 19.74 of the CMC.

Finally, the proposed modification of the CSP would enhance the overall environment of the East Avenue Marketplace by increasing the amount of direction to commercial services provided to the public while ensuring that the center identification signs are pleasing in appearance and installed in a visible yet unobtrusive locations.

### Architectural Review

According to the Chico Municipal Code Section 19.18.060, the Architectural Review and Historic Preservation Board shall determine whether or not a project adequately meets adopted City standards and design guidelines, based upon the following findings:

1. *The proposed development is consistent with the General Plan, any applicable specific plan, and any applicable neighborhood or area plans.*

The proposed modification is designated Commercial Mixed Use (CMU) on the General Plan Land Use Diagram. Since the proposed modification regulates the installation and location of commercial signage, it is generally consistent with the commercial uses intended for the CMU land use designation.

2. *The proposed development, including the character, scale, and quality of design are consistent with the purpose/intent of chapter 19.18 of the Chico Municipal Code and any adopted design guidelines.*

The additional center identification sign that would be installed as a result of the proposed modification of the East Avenue Marketplace CSP would be a positive contribution to the existing streetscape while enhancing the identity of the shopping center consistent with DG 1.6.11. In addition, the size and design of the new center identification sign would match the two existing signs for the shopping center, consistent with DG 1.6.12. Finally, the lettering of the new center identification sign would not exceed 16 inches consistent with

DG 1.6.15 and the 7.6 foot height and base mounted design of the new sign would be consistent with DG 1.6.16.

3. *The architectural design of structures, including all elevations, materials and colors are visually compatible with surrounding development. Design elements, including screening of equipment, exterior lighting, signs, and awnings, have been incorporated into the project to further ensure its compatibility with the character and uses of adjacent development.*

The new center identification sign would be designed to include materials, colors, and illumination that is visually compatible with the existing shopping center. Installation of the new signage would not be anticipated to result in compatibility issues with future commercial development in the area.

4. *The location and configuration of structures are compatible with their sites and with surrounding sites and structures, and do not unnecessarily block views from other structures or dominate their surroundings.*

The new center identification sign that would be permitted by the modification to the CSP would be identical in size and design with the two existing center identification signs which are compatible with the surrounding development. The new center identification sign permitted is appropriately sized for its planned location and it would not block or dominate the surroundings.

5. *The general landscape design, including the color, location, size, texture, type, and coverage of plant materials, and provisions for irrigation and maintenance, and protection of landscape elements, have been considered to ensure visual relief, to complement structures, and to provide an attractive environment.*

The existing landscape of the East Avenue Marketplace shopping center will provide visual relief and an attractive environment around the new center identification sign permitted by the proposed modification to the CSP.

## **RECOMMENDED CONDITIONS OF APPROVAL FOR AR 17-05**

1. All approved sign permits shall note on the cover sheet that project signage shall comply with AR 17-05 (East Avenue Marketplace CSP). No building permits related to this approval shall be finalized without authorization of Planning staff.
2. The criteria for signs approved under this Comprehensive Sign Program are as provided under Attachment D of this report, entitled "Comprehensive Sign Program, East Avenue Marketplace, Chico, CA, (AR 17-05)".

## **PUBLIC CONTACT**

Public notice requirements are fulfilled by placing a notice on the project site and by posting of the agenda at least 10 days prior to the ARHPB meeting.

## **ATTACHMENTS**

- A. Location Map
- B. Center Identification Sign Location Map
- C. Proposed Center Identification Sign

D. Modified Comprehensive Sign Program

**DISTRIBUTION**

Internal (2)

Mark Corcoran, Senior Planner

Files: AR 17-05

External (6)

Sierra Central Credit Union – Steve Henderson, 1351 Harter Pkwy., Yuba City, CA 95993

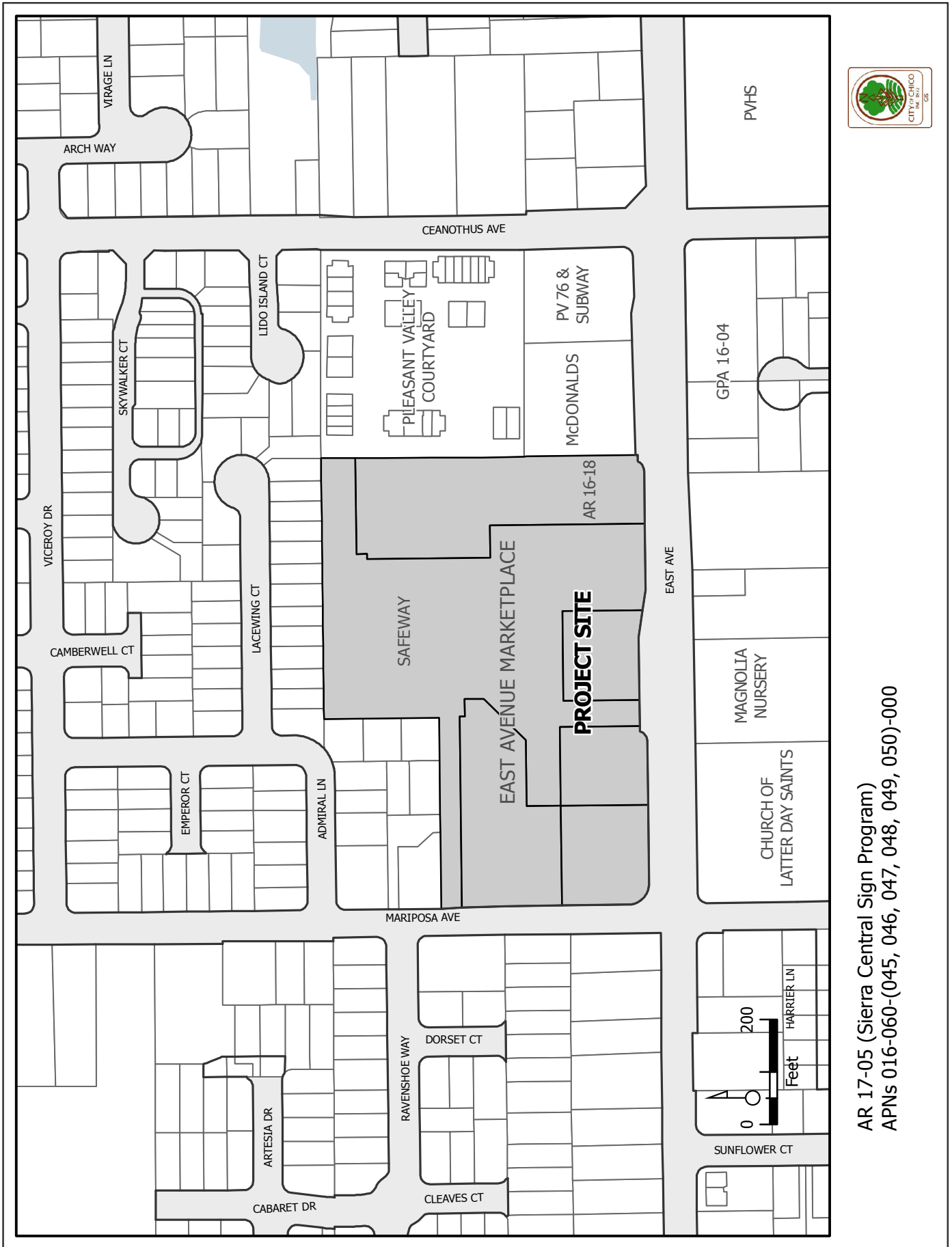
Petredis Law Offices – Nick Petredis, 50 W. San Fernando St., Ste. 1415, San Jose, CA 95113

Peters Law Chico – Mark Habib, 414 Salem St., Chico, CA 95928

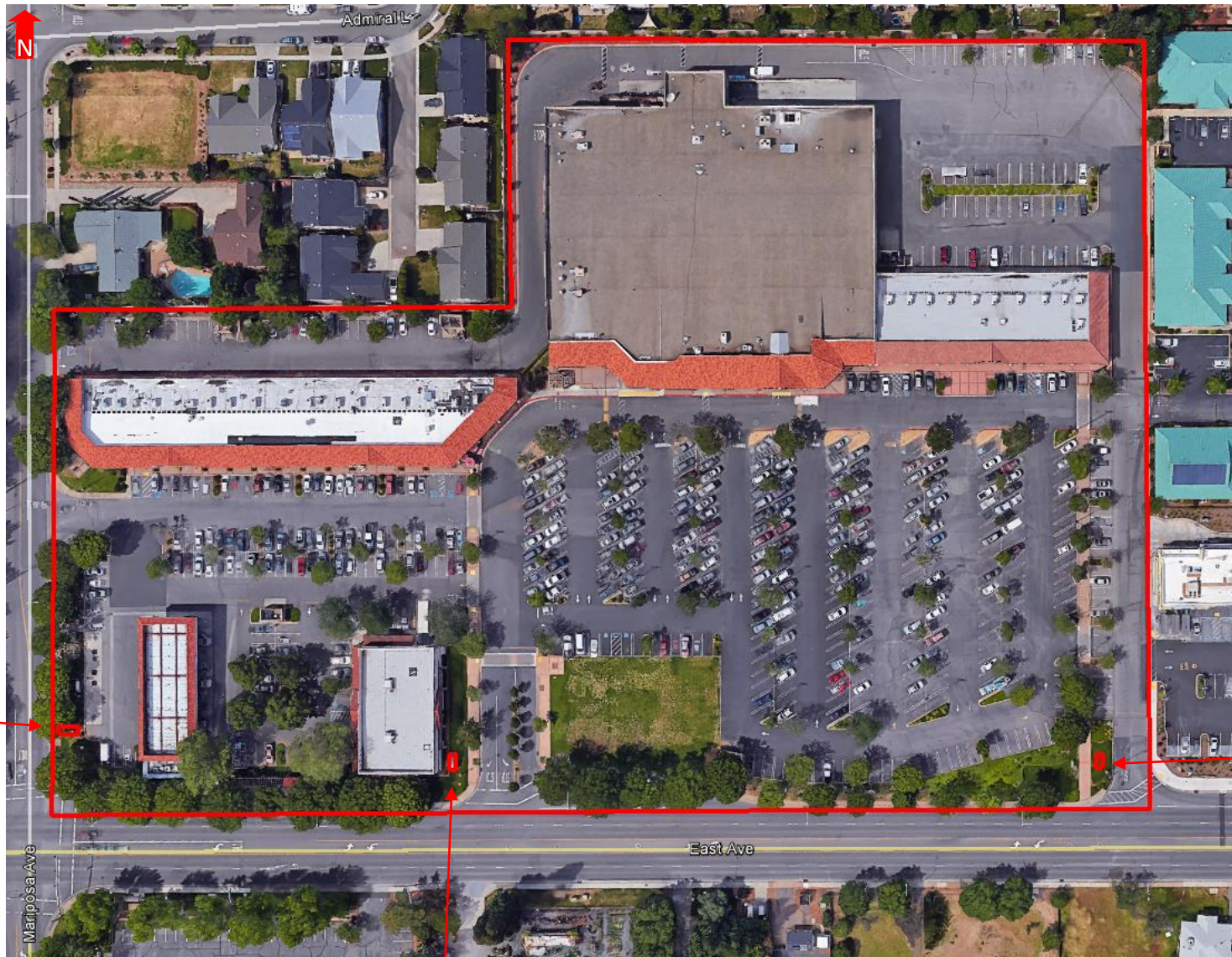
Safeway Inc. – c/o Store # 1125, 1371 Oakland Blvd., Ste. 200, Walnut Creek, CA 95496

Chico 5 LLC - 2101 Tennessee St., Vallejo, CA 94590

Logic Properties – 472 Antonio Dr., Williams, CA 95487



AR 17-05 (Sierra Central Sign Program)  
 APNs 016-060-(045, 046, 047, 048, 049, 050)-000



**Center  
Identification  
Sign 1, Southern  
Driveway from  
Mariposa  
Avenue**

**Center  
Identification  
Sign 3, Eastern  
Driveway from  
East Avenue**

**Center Identification Sign  
2, Western Driveway from  
East Avenue**

Not to scale. For general location purposes only.



**HUPP SIGNS**  
 & LIGHTING, INC.  
 530-345-7078  
 70 Loren Ave. Chico, CA 95928  
 License #969949

www.huppsigns.com  
 SIGN DESIGN  
 MANUFACTURING  
 INSTALLATION & SERVICE

THIS DESIGN IS THE EXCLUSIVE PROPERTY OF HUPP SIGNS AND CANNOT BE REPRODUCED, IN WHOLE OR IN PART, WITHOUT HUPP SIGNS'S PRIOR WRITTEN APPROVAL.

**SALES ASSOCIATE**  
 Kathy Cunningham

**JOB NUMBER**

**CUSTOMER NAME**  
 SCCU AND SAFEWAY

**CUSTOMER ADDRESS**  
 1366 EAST AVE  
 CHICO, CA

**CUSTOMER PHONE#**

**DESIGN PHASE**  
 1 design

REVISED BY	DATE
Kathy C	1-9-17

**APPROVALS INCLUDE**  
 DESIGN, COLOR, SPELLING

**CUSTOMER APPROVAL**

PRINT NAME \_\_\_\_\_  
 SIGN NAME \_\_\_\_\_  
 DATE \_\_\_\_\_

**HUPP STAFF APPROVAL**

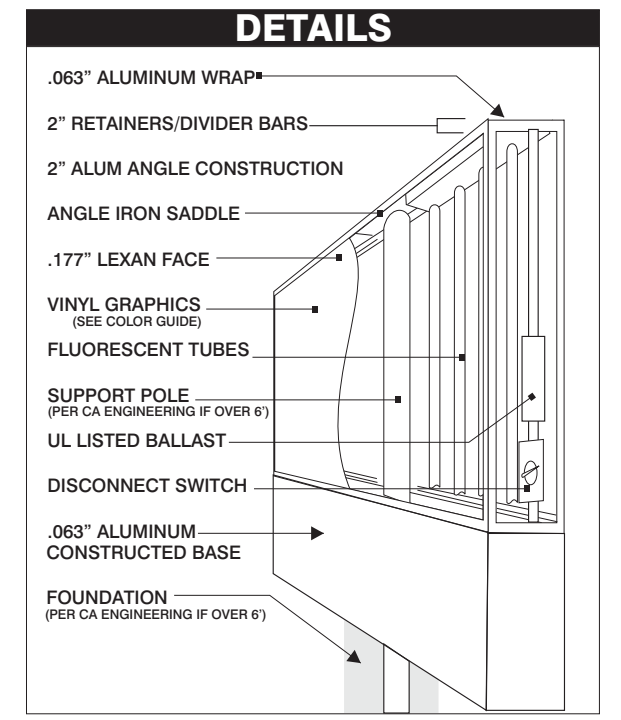
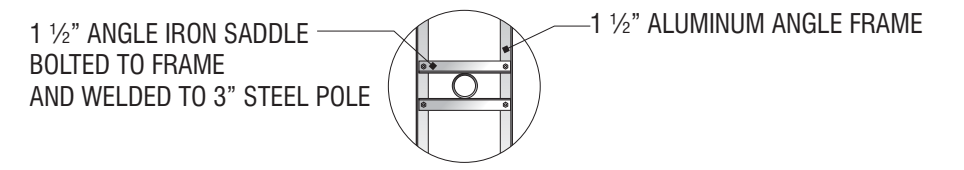
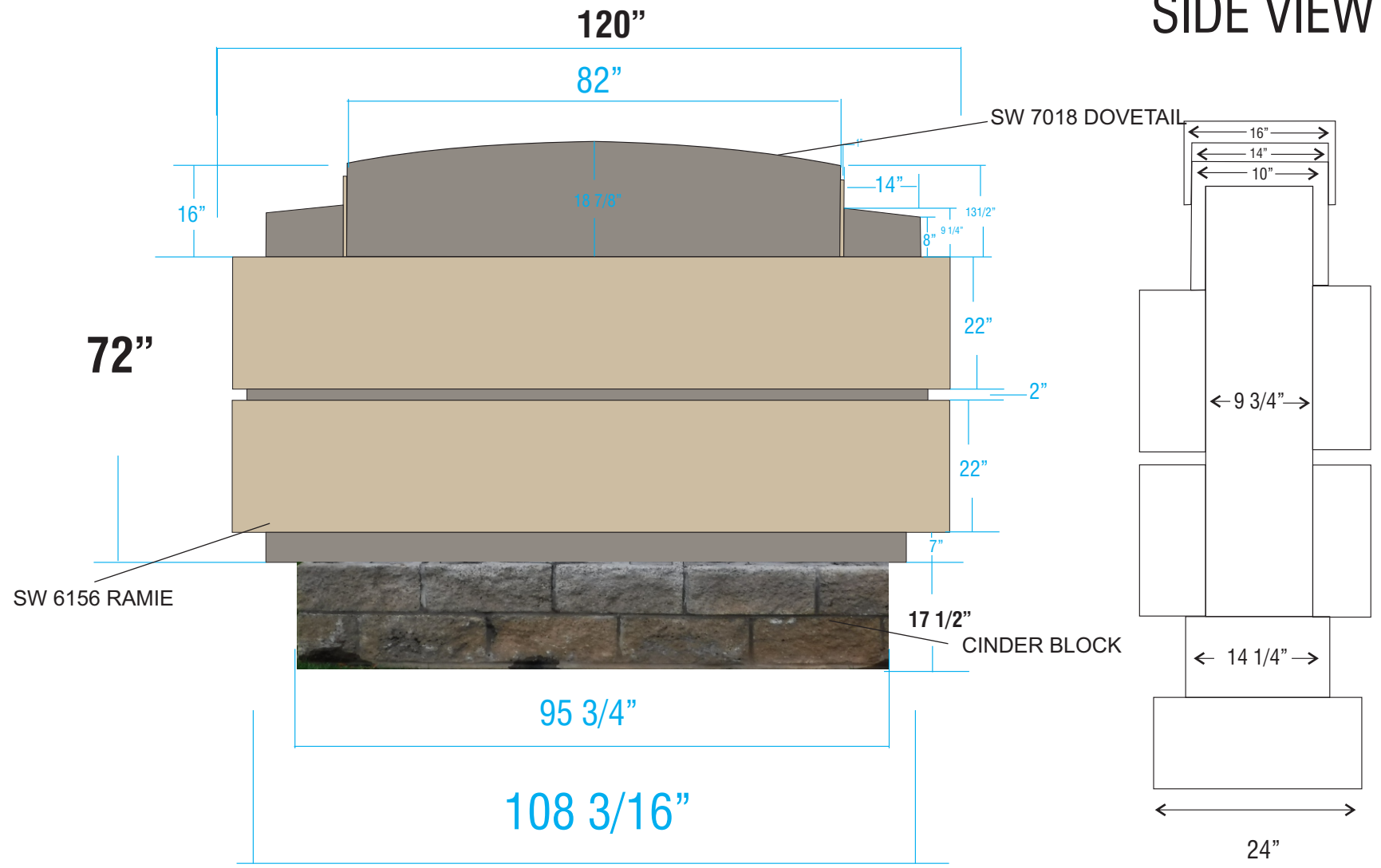
PRINT NAME \_\_\_\_\_  
 SIGN NAME \_\_\_\_\_  
 DATE \_\_\_\_\_

This sign is intended to be installed in accordance with the requirements of article 600 of the national electric code and/or other applicable local codes. This includes proper grounding and bonding of the sign.

PAGE #   1  

# D/F LED ILLUMINATED MONUMENT SIGN

## SIDE VIEW



**COLOR GUIDE**

V1	3M VINYL	XXXXXXXX
V2	3M VINYL	XXXXXXXX
P1	PAINT:	COLOR HERE
	TEXTURE:	NONE
	FINISH:	GLOSS

74.59 SQ FT

FOUNDATION PER CA ENGINEERING

**HUPP SIGNS**  
• LIGHTING, INC.  
**530-345-7078**  
 70 Loren Ave. Chico, CA 95928  
 License #969949,  
 www.huppsigns.com

SIGN DESIGN  
 MANUFACTURING  
 INSTALLATION & SERVICE

THIS DESIGN IS THE EXCLUSIVE  
 PROPERTY OF HUPP SIGNS AND  
 CANNOT BE REPRODUCED, IN WHOLE  
 OR IN PART, WITHOUT HUPP SIGNS'S  
 PRIOR WRITTEN APPROVAL

**SALES ASSOCIATE**  
 Kathy Cunningham

**JOB NUMBER**

**CUSTOMER NAME**  
 SCCU AND SAFEWAY

**CUSTOMER ADDRESS**  
 1366 EAST AVE  
 CHICO, CA

**CUSTOMER PHONE#**

**DESIGN PHASE**  
 1 design

REVISED BY	DATE
Kathy C	1-9-17

**APPROVALS INCLUDE**  
 DESIGN, COLOR, SPELLING

**CUSTOMER APPROVAL**

PRINT NAME \_\_\_\_\_  
 SIGN NAME \_\_\_\_\_  
 DATE \_\_\_\_\_

**HUPP STAFF APPROVAL**

PRINT NAME \_\_\_\_\_  
 SIGN NAME \_\_\_\_\_  
 DATE \_\_\_\_\_

This sign is intended to be installed in accordance with the requirements of article 600 of the national electric code and/or other applicable local codes. This includes proper grounding and bonding of the sign.

PAGE #   1  

# 1/2" CLEAR ACRYLIC PUSH THRU COPY



**EXISTING MONUMENT TO BE REMOVED**



# **COMPREHENSIVE SIGN PROGRAM**

## **SIGN CRITERIA**

### **EAST AVENUE MARKET PLACE**

#### **CHICO, CA**

#### **(AR 17-05)**

These criteria have been established for the purpose of maintaining a continuity of quality and aesthetics throughout the Shopping Center for the mutual benefit of all tenants and to comply with the regulations of the City of Chico. Conformance will be strictly enforced and any installed nonconforming or unapproved signs must be brought into conformance at the expense of the tenant.

#### **~~ALL COMPANIES BIDDING TO MANUFACTURE~~**

~~All companies bidding to manufacture these signs are advised that no substitutes will be accepted by Landlord unless so indicated in the specifications and approved by Landlord and Tenant. Any deviation from these specifications may result in Landlord's or Tenant's refusal to accept the sign.~~

#### **A. General Requirements**

1. Before fabrication, Tenant shall submit two (2) copies of detailed, colored drawings indicating the location, size, layout, design, dimensions, colors, illumination, materials and method of attachment of all signage to Landlord for approval. All signs shall be reviewed for conformance with these criteria and overall design quality. Approval or disapproval of sign submittals based on aesthetics of design shall remain the right of the Landlord or authorized representative and the City of Chico.
2. Sign design, permits, fabrication, installation and costs associated therewith are the sole responsibility of the Tenant. Tenant shall be responsible for the fulfillment of all requirements and specifications including those of the City of Chico.
3. No animated, flashing or audible signs will be permitted.
4. Signs and their installation shall comply with all local building and electrical codes and the City of Chico Sign Ordinance.
5. No portable signs will be permitted. No exposed raceways, crossovers or conduits will be permitted. All cabinets, conductors, transformers and other equipment shall be concealed. Painted lettering will not be permitted.
6. Tenant is responsible for the installation and maintenance of signage. Should Tenant's signage require maintenance or repair, Landlord will give Tenant thirty (30) days written notice to perform said maintenance or repair. Should Tenant fail to do same, Landlord shall undertake repairs and Tenant shall reimburse Landlord within ten (10) days from receipt of invoice.

#### **B. Location of Signs**

1. All wall signs or devices advertising an individual use, business or building shall be attached to the building at a location to be approved by Landlord.

2. Three (3) Center Identification Signs meeting the standards included in Section C. Design Performance may be located as follows: one (1) on the Mariposa Avenue frontage near the gas station, and one (1) at each of the driveway entrances from East Avenue (see Exhibit A).

### **C. Design Performance**

Minor variations to the specifications contained herein will be considered on a case by case basis by Landlord when it is determined such consideration is in the best interest of the Shopping Center and in conformance with the City of Chico Sign Ordinance.

#### **1. Wall Signs–~~Shop Building 2~~**

a. All wall signs shall be of individual, internally illuminated letters, mounted electrically and individually as shown on Exhibit A attached hereto. Sign cabinets will not be permitted. Letter faces shall be three-sixteenth inch (3/16") acrylic with three-fourth inch (3/4") trimcap retainers used at the perimeter. Trimcap color shall be bronze or gold. Returns of individual letters shall be five inches (5") deep, 24 GA. sheet metal, "Pan Channel" type. Sign face colors will be considered on a case by case basis and will be approved at Landlord's discretion. Exterior return color shall be Dupont Duranodic #313 Dark Bronze. Raceway shall be painted Fuller O'Brien #G-101 "Rough Wood" #312-93 high gloss enamel. Neon tubing shall be fifteen millimeters (15mm).

b. Maximum square foot area of wall signs including logo shall not exceed the lineal frontage of shop multiplied by 1.20.

c. The height of letters in all signs shall not exceed twenty-four inches (24"). Logo height and width shall not exceed twenty-four inches (24").

d. Maximum length of all wall signs shall not exceed eighty percent (80%) of the lineal frontage of the Tenant's leased area when that frontage is twenty feet (20') or less and seventy percent (70%) when the frontage is greater than twenty feet (20').

#### **2. Under-canopy Signs**

a. Each Tenant may install a non-illuminated under-canopy sign in accordance with Exhibit B attached hereto. Said sign shall be located as depicted on that exhibit.

b. One (1) under-canopy sign shall be allowed per Tenant.

c. All signs shall be constructed of two inch (2") thick, clear heart, kiln dried redwood.

d. Sign shall be primered and painted with Fuller O'Brien #G-1 01 "Rough Wood" exterior paint

e. Inset border shall be routed one-fourth inch (1/4") deep, one-half inch (1/2") wide. The outside border and sign face shall remain smooth (~~See: Exhibit B~~) (see Exhibit B).

f. Tenant name area shall be #015 White acrylic, one-eighth inch (1/8") thick with vinyl letters and/or logos (See: Exhibit B).

- g. Vinyl lettering and/or logo colors shall match electric sign face color and shall be subject to Landlord approval.
- h. Sign shall be mounted with sixteen-inch (16") long by one-fourth inch (1/4") All Thread Rod with two two-and-one-fourth inch (2-1/4") wood balls between sign and overhang (See: Exhibit B).
- i. Wood balls shall be painted with #109-L One Shot Metallic Gold Lettering Enamel.
- j. Each Tenant shall submit one (1) copy of the sign design and colors to Landlord for approval prior to fabrication and installation.
- k. The square foot area of this sign will be counted as part of the total square foot area allowed for each Tenant's signs (See: Wall mounted sign section).
- l. A building permit will be required from the Chico Building Department prior to installation of this sign.

### 3. Center Identification Signs

a. The three (3) Center Identification Signs (CIS) shall be similar in dimensions and design including bases composed of split-face cement block, and internal illumination though vinyl letters with an opaque negative area (see Exhibit C).

c. Each CIS shall not exceed 90 inches in height and 120 inches at its widest point. The overall sign area for each CIS shall not exceed 75 square feet per sign face or 150 square feet over all.

d. Each CIS shall include conforming stylized text identifying the shopping center as the East Avenue Marketplace above any tenant identification signs.

e. Individual internally illuminated channel letters and logos for the tenant identification signs shall not exceed 22 inches in height.

f. A building permit shall be obtained from the Chico Building Department prior to the installation of any CIS.

### **D. Construction Requirements**

1. All exterior signs shall be installed per ~~Exhibit A~~ **Exhibit D** attached hereto. Signs shall be the U.L. label and comply with all required codes. Exterior signs shall be secured by concealed fasteners, stainless steel, nickel or cadmium plated.
2. Wall sign circuit, conduit and pull box will be provided to edge of canopy by Landlord.
3. No labels will be permitted on the exposed surface of signs except those required by local ordinance which shall be applied in an inconspicuous location.
4. Sign contractor shall repair any damage to any work caused by his work. Damage to structure that is not repaired by the sign contractor shall become the Tenant's responsibility to correct.
5. Tenant shall be fully responsible for the operations of its sign contractors.

### **E. Insurance**

Sign company<sup>ies</sup> shall carry Workers' Compensation and Public Liability insurance against all damage suffered or done to any and all persons and/or property while engaged in the construction or erection of signs in the amount of-five hundred thousand dollars (\$500,000.00) combined single limit.

**F. Maintenance**

Tenant is responsible for the maintenance of signs. In doing so, tenant shall keep the sign and its lighting in good appearance and proper operable condition.

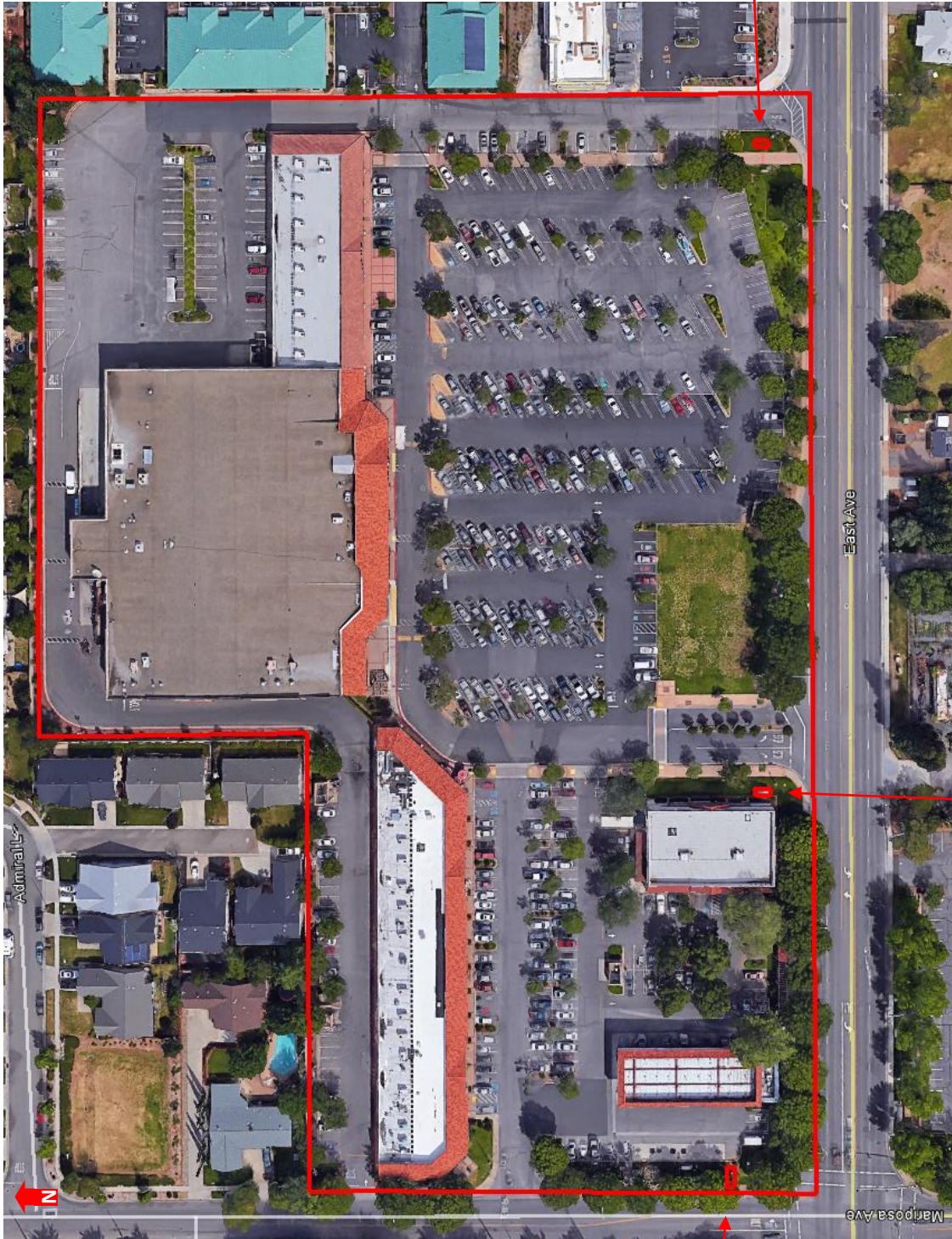
**G. Miscellaneous Requirements**

At the expiration or sooner termination of Tenant's lease term, Tenant shall be required to remove all signs, patch the canopy and fascia and paint the patched area(s) to match the surrounding areas.

**H. Colors**

Color are subject to Landlord's approval.

**Exhibit A**



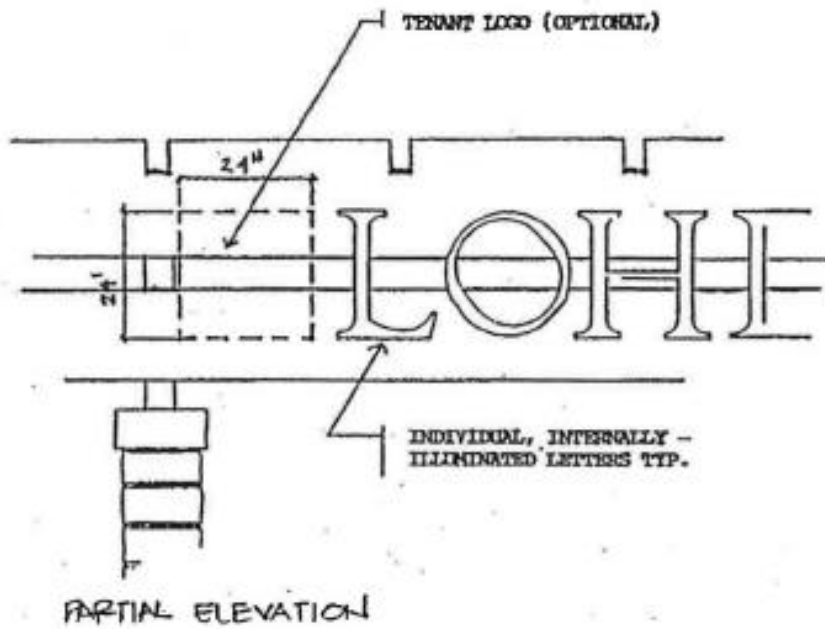
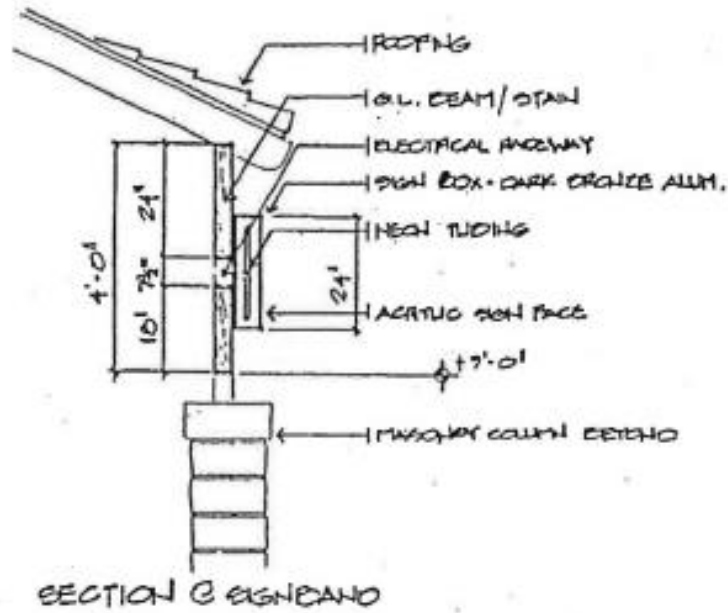
**Center  
Identification  
Sign 1, Southern  
Driveway from  
Mariposa  
Avenue**

**Center  
Identification  
Sign 3, Eastern  
Driveway from  
East Avenue**

**Center Identification Sign 2, Western  
Driveway from East Avenue.**

Not to scale. For general location purposes only.

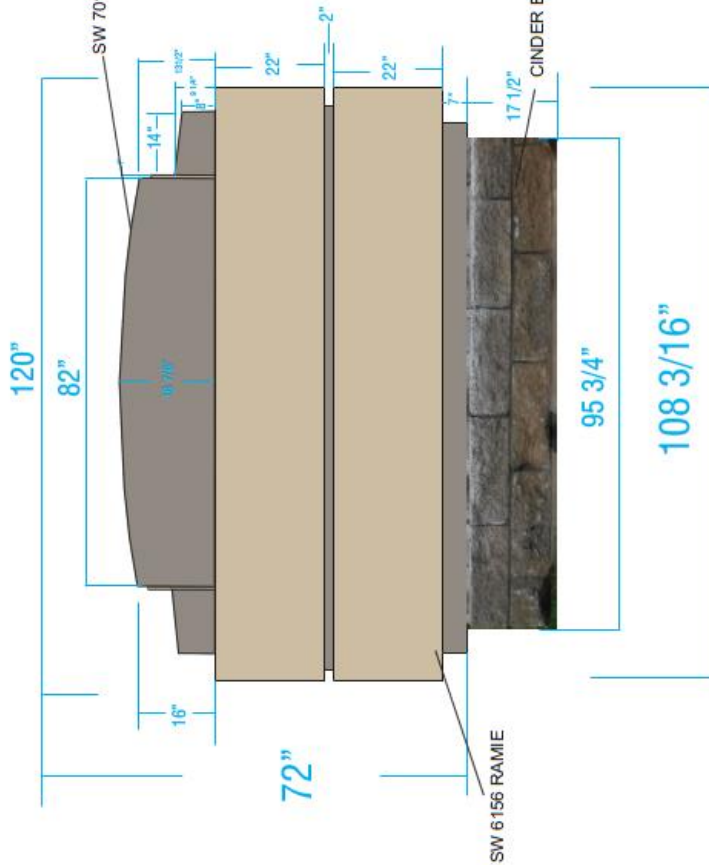
**Exhibit B**



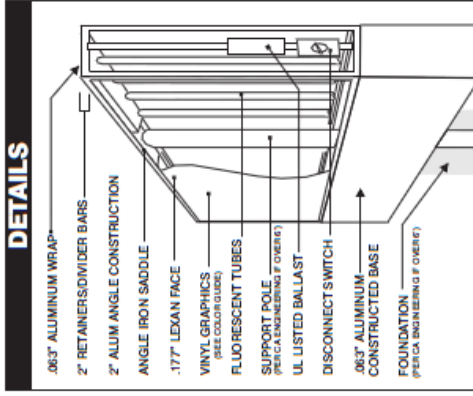
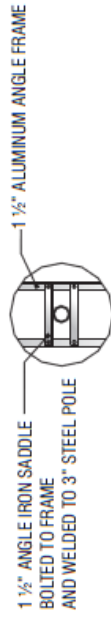
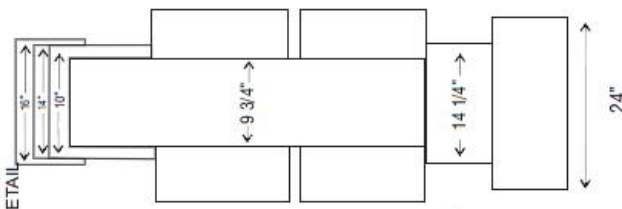


**Exhibit C**

**D/F LED ILLUMINATED MONUMENT SIGN**



**SIDE VIEW**



COLOR GUIDE		TEXTURE	NONE	FINISH	GLOSS
V1	SW VINYL 30000000				
V2	SW VINYL 20000000				
P1	PAINT COLOR HERE				

**74.59 SQ FT**

**FOUNDATION PER CA ENGINEERING**

**Exhibit D**

