



Architectural Review
and Historic Preservation Board
Agenda Report

Meeting Date 02/17/16

DATE: January 28, 2016

File : AR 15-33

TO: Architectural Review and Historic Preservation Board

FROM: Mike Sawley, Associate Planner, (879-6812, mike.sawley@chicoca.gov)
Community Development Department

RE: Reed Apartments, Phase II
1131 W. 5th Street and 505 Oak Street, AP Nos. 004-201-002 and 004-201-001

RECOMMENDATION

Staff recommends that the Architectural Review and Historic Preservation Board adopt the required findings contained in the agenda report and approve the proposed project, subject to the recommended conditions.

Proposed Motion

I move that the Architectural Review and Historic Preservation Board adopt the required findings contained in the agenda report and approve Architectural Review 15-33 (Reed Apartments), subject to the recommended conditions.

BACKGROUND

The applicant proposes to construct a five-unit apartment complex on 0.18-acres located on West 5th Street between Oak Street and Walnut Street (see **Attachment A**, Vicinity Map and **Attachment B**, Architect's Project Description). The project would create a second phase of an existing 5-unit complex constructed 5 years ago. The site is designated Medium-High Density Residential by the Chico General Plan and is zoned R3 (Medium-High Density Residential). Surrounding land uses include a mixture of single-family residential and multi-family residential to the north, multi-family residential to the west, single-family residential to the south, and commercial/service uses to the east along the Walnut Street/Hwy 32 corridor.

Following a merger with the existing apartments located at 505 Oak Street, this proposal would result in a new 3-story building containing five carriage-house style units with first floor garages and living space above (see **Attachment C**, Site Plan and **Attachment D**, Floor Plans). The design would be a mirror image of the existing 5-unit building constructed at 505 Oak Street, and the resultant residential density would be 14.8 du/ac, which is consistent with the allowable range of 14.1 to 22 du/ac for the R3 district.

The new building would have front doors facing east, with porches leading to a common walkway connecting out to the public right-of-way along West 5th Street. The new and existing units would share a common driveway and two vehicle parking spaces would be provided for each unit within private garages. The request includes a parking reduction of two spaces, with the intent that guest will park along the street frontages.

Landscaping is proposed around the new building, including two new planters for shade trees in the parking area (see **Attachment E**, Landscape Plans). Parking lot shading is estimated to reach approximately 51 percent at maturity, utilizing new summershade maple trees to

comprise most of the shade. All new landscape areas are designed for moderate water usage, which is anticipated to consume approximately 80 percent of the maximum water allowable pursuant to AB 1881 water conservation requirements.

As shown on the landscape plan, each new unit would be equipped with two inverted-U bicycle parking fixtures, one inside the front door and one on the front porch, resulting in four bicycle parking spaces for each unit.

The proposed layout would preserve an existing 30-inch valley oak along the southerly boundary between the new building and relocated trash enclosure. Other existing trees, such as an incense cedar and multiple Italian cypresses, would be removed and require a combination of onsite plantings and payment of in-lieu fees to satisfy the tree replacement requirements of the City's Tree Preservation Regulations (CMC 16.66).

The proposed elevations illustrate the three-story structure with gables facing the front and rear of each unit (see **Attachment F**, Elevations, and **Attachment G**, Photos). The exterior walls of each floor vary materials and colors to provide interest. The ground floor features stucco surfaces with a sand finish; the second story features horizontal hardi-plank (or equivalent) lap siding; the third story features vertical board-and-batten surfaces. Cantilevered masses on the second and third stories are stucco sand finish. Roof-mounted air condenser units would be hidden within a central roof well, similar to the existing apartment building.

Colors are earthtone, ranging in hues of light brown, khaki, and olive green (see **Attachment H**, Colors and Materials). Composition shingles cover steep gable roofs. Shed roofs, supported by vernacular-style square columns, cover second floor balconies on the front (east) elevation. The balconies, supported by the same-style columns, create covered entry porches below, six feet in depth.

Modern wall pack lights are proposed over each garage door (see **Attachment I**, Lighting), and recessed can-lights are proposed in the ceilings of balconies and porches. A condition would require the new wall packs to match or be substantially consistent with the existing wall packs on Phase I.

DISCUSSION

The proposed project would expand upon an existing, successful development that represents an appropriate intensity within the R3 zoning district. The roofline evokes historic industrial warehouses (by the array of steep gable roofs, similar to buildings along Orange Street), while the elevations depict residential cottages with varied materials and colors that distinguish each floor level. Cantilevered masses on the north and south elevations, and balconies and front porches on the front elevation provide good articulation for large building mass.

The project is located within walking distance to Chico State and nearby commercial and service uses situated along Walnut Street/Hwy 32. An existing bus transit route runs on Oak Street. Usable porches are included on the first and second stories of each unit, affording private or semi-private outdoor space for each unit. Garage parking minimizes views of parked vehicles and rooftop condenser units would be screened very effectively.

Design Guidelines

Similar to the existing apartments at 505 Oak Street, the design bolsters historic neighborhood identity by replicating the sawtooth pattern of the gable roofs that was originally established on existing warehouses along the City's rail corridor (along Orange Street). This is consistent with Design Guidelines that calls for incorporating recognizable design elements that create a sense of place by referencing ties to the surrounding neighborhood (DGs 1.1.11, 1.1.34, 1.2.12, 1.2.21 and 1.2.22).

The site design is challenged by DGs that encourage a pedestrian orientation via facing building entries and porches toward the street (DGs 4.1.11, 4.1.13 and 4.1.24), however, there are offsetting benefits that result from the project using a shared driveway and architecture that is complementary of the existing 3-story apartments. See Architect's Project Description, **Attachment B**, for additional DG analysis.

Parking

As stated above, the proposal includes a request to reduce the number of off-street parking by two spaces. Such a reduction in off-street parking may be approved by the Board subject to making certain additional findings as outlined below. In this case, staff supports the reduction of off-street parking based on the site's acceptable proximity to shopping and CSUC, parking supplies are not typically overburdened in the immediate area, the site is served by a bus transit route as well as a Class III bicycle route, and the project includes much more covered bicycle parking than required by the code. The additional findings required to approve a reduction in off-street parking are provided below.

Trees

The proposed design would retain a large, healthy oak tree near the location of the proposed new trash enclosure. To ensure proper protection of the tree during construction, a condition is recommended that would require a Tree Protection Plan in compliance with CMC 19.68.060. The plan would be submitted in conjunction with building/grading permit plans, and would cover all phases of the project, including site preparation, construction, and post-construction.

Fencing

The site plan labels both existing and proposed fencing as "6' tall 1x6 cedar fencing with 2x4 cap" and includes a detail depicting the same. Since the existing fence does not have a 2x4 cap a condition is recommended to add the 2x4 cap for a consistent appearance.

In conclusion, the project would advance City goals of achieving urban densities in the R3 zoning district and would do so in an aesthetically pleasing manner by modeling the new structure after an existing, successful 3-story apartment complex.

RECOMMENDED DISCUSSION ITEMS

Driveway Width: Provided that DGs 4.1.32 and 4.1.51 encourages shared driveways to reduce the amount of impervious surfaces associated with development projects, discuss if the drive aisle shall be reduced in width to avoid excessive amounts of paved area and increase the amount of landscape area along the eastern boundary of the site. For reference, CMC 19.70 only requires a 24-foot wide drive aisle to accommodate vehicle circulation and the proposed drive aisle widens to 35 feet between the buildings. Reducing the amount of paved area would also enable smaller-canopy shade trees to be planted in the parking area, reducing potential

conflicts between tree growth and the new building. Staff recommends hearing any supporting rationale for the proposed driveway width from the applicant and weighing that against the standards, DGs, and site planning issues cited above.

REQUIRED FINDINGS FOR APPROVAL

Environmental Review

The project has been determined to be categorically exempt under Section 1.40.220 of the Chico Municipal Code, and pursuant to the California Environmental Quality Act (CEQA) Guidelines Section 15332 (In-Fill Development Projects). This exemption applies to infill projects which: are consistent with the general plan and zoning; are on sites less than five acres in size within the City limits; substantially surrounded by urban uses; have no value as habitat for endangered, rare, or threatened species; would not create any significant effects relating to traffic, noise, air quality, or water quality; and can be adequately served by all required utilities and public services.

Architectural Review

According to Chico Municipal Code Section 19.18.060, the Architectural Review and Historic Preservation Board shall determine whether or not a project adequately meets adopted City standards and design guidelines, based upon the following findings:

1. *The proposed development is consistent with the General Plan, any applicable specific plan, and any applicable neighborhood or area plans.*

The proposal is consistent with several General Plan policies, including those that encourage compatible infill development (LU-1, LU-4, and CD-5). The project design is bicycle friendly in that ample tenant and guest bicycle parking is provided at convenient locations for each unit, consistent with policy CD-3.2. The project includes new landscaping with low to moderate water needs, consistent with sustainability policies that promote water conservation and energy efficiency (SUS-4.2). The project is not located within the bounds of any neighborhood or area plans.

2. *The proposed development, including the character, scale, and quality of design are consistent with the purpose/intent of this chapter and any adopted design guidelines.*

The project promotes orderly development by expanding upon an existing, successful apartment complex, providing sufficient vehicle parking and ample bicycle parking for the new units. The proposal is consistent with Design Guidelines that call for creating a sense of place by incorporating recognizable design elements and enhancing the historic neighborhood identity (DGs 1.1.11, 1.1.34, 1.2.12, 1.2.21 and 1.2.22). Although the site design is challenged by DGs that encourage a pedestrian orientation via facing building entries and porches toward the street, there are offsetting benefits that result from the project using a shared driveway and architecture that is complementary of the existing 3-story apartments.

3. *The architectural design of structures, including all elevations, materials and colors are visually compatible with surrounding development. Design elements, including screening of equipment, exterior lighting, signs, and awnings, have been incorporated into the project to further ensure its compatibility with the character and uses of adjacent development.*

The sawtooth pattern of the gable roofs is reminiscent of historic warehouses along the City's rail corridor and other, newer projects east of the site. Materials and color are compatible with other residential uses in the neighborhood. Exterior equipment will be properly screened from view by a rooftop well, paint and landscape plantings.

4. *The location and configuration of structures are compatible with their sites and with surrounding sites and structures, and do not unnecessarily block views from other structures or dominate their surroundings.*

The proposed three-story building will be the same size as the existing 5-unit building located on the adjacent lot at 505 Oak Street. Following a merger with 505 Oak Street, the new building will meet all setbacks and will be compatible with the site. The new building may block a limited number of existing private views, but would be architecturally compatible with the surrounding area. The building would overshadow adjacent off-street parking areas associated with the residential use to the south and a commercial use to the east, and would be approximately 90 feet from the single-family residences located across East 5th Street to the north. Therefore, it is found that the proposed structure is compatible with the site and will not unnecessarily block views from other structures.

5. *The general landscape design, including the color, location, size, texture, type, and coverage of plant materials, and provisions for irrigation and maintenance, and protection of landscape elements, have been considered to ensure visual relief, to complement structures, and to provide an attractive environment.*

Proposed landscape design would provide a small variety of plantings that repeat in harmony with the pattern of spaces provided between the new units. A mature oak tree would be retained, buffering the new building from the existing residential use to the south, hastening an established appearance for the new construction.

Parking Reduction

According to Chico Municipal Code Section 19.70.050, the Board may approve a reduction in the minimum number of off-street parking spaces for a project based upon making the following findings:

1. *The project meets one of the following:*
 - a. *The site is zoned RMU or has a –COS overlay zone;*
 - b. *The site is located within an area of mixed-use development;*
 - c. *The project will implement sufficient vehicle trip reduction measures (such as vehicles loan programs and transit passes) to offset the reduction; or*
 - d. *The area is served by public transit, bicycle facilities, or has other features which encourage pedestrian access.*

The project site is located within an area of horizontal mixed-use development consisting of a variety of commercial and service uses along the Walnut Street corridor, and is approximately nine blocks from the CSUC campus. In addition, the site is served by a bus transit route as well as a Class III bicycle along Oak Street, and the project will include ample covered tenant and guest bicycle parking, well in excess of the minimum amount required.

2. *The proposed parking reduction is not likely to overburden public parking supplies in the project vicinity.*

The proposed finished project will provide all but two of the off-street vehicle parking spaces required by the City's parking regulations, both of which are guest spaces. As a corner-lot development with a single driveway, there will be seven on-street spaces along the immediate project frontage. Guests are likely to prefer the on-street spaces in general, because they are closer to the front doors of the units than the proposed off-street parking area. Based on information provided by the applicant, as well as observations and informal interviews of nearby residents by staff, public parking supplies in the project vicinity are rarely fully occupied – typically only when there are large evening gatherings in the area. It is for these reasons that the proposed reduction of two off-street parking spaces is not likely to overburden public parking supplies.

RECOMMENDED CONDITIONS OF APPROVAL

1. All approved building plans and permits shall note on the cover sheet that the project shall comply with AR 15-33 (Reed Apartments). The approval documents for this project are date stamped Jan 22, 2016.
2. The approval of AR 15-33 (Reed Apartments) shall only become effective upon recordation of a merger of the parcels underlying the project site, AP Nos. 004-201-002 and 004-201-001.
3. The new wall pack light fixtures shall match or be substantially consistent with the existing wall packs on the Phase I building located at 505 Oak Street.
4. In conjunction with building permit or grading permit review, the developer shall submit a Tree Protection Plan meeting the requirements of CMC 19.68.060. The Plan shall be prepared by a certified arborist and specify the actions necessary to minimize potential construction impacts on the trees that are to be retained, as specified by the approved plans. The Plan shall cover all phases of the project including site preparation, active construction, and post-construction disposition of the areas around the trees.
5. All building and landscape plans shall note the addition of a 2x4 cap on existing fencing so that all perimeter 6-foot fencing is consistent with the detail shown on the approved site plan.
6. All wall-mounted utilities and roof or wall penetrations, including vent stacks, utility boxes, exhaust vents, gas meters and similar equipment, shall be screened by appropriate materials and colors. Adequate screening shall be verified by Planning staff prior to issuance of a certificate of occupancy.
7. All new electric, telephone, and other wiring conduits for utilities shall be placed underground in compliance with CMC 19.60.120.

PUBLIC CONTACT

Public notice requirements are fulfilled by placing a notice on the project site and by posting of the agenda at least 10 days prior to the ARHPB meeting.

ATTACHMENTS

- A. Location Map
- B. Architect's Project Description
- C. Site Plan
- D. Floor Plan
- E. Landscape Plan
- F. Building Elevations (3 sheets)
- G. Photos of Existing Apartments at 505 Oak Street
- H. Colors and Materials
- I. Lighting Details

DISTRIBUTION (6)

Bob Summerville, Senior Planner

Mike Sawley, Associate Planner

Greg Peitz, 383 Rio Lindo Ave, Chico, CA 95926

Brian Firth, 627 Broadway Street, Suite 220, Chico, CA 95928

Reed-Lieberman, LLC, 48 Comanche Ct., Chico, CA 95928

File: AR 15-33

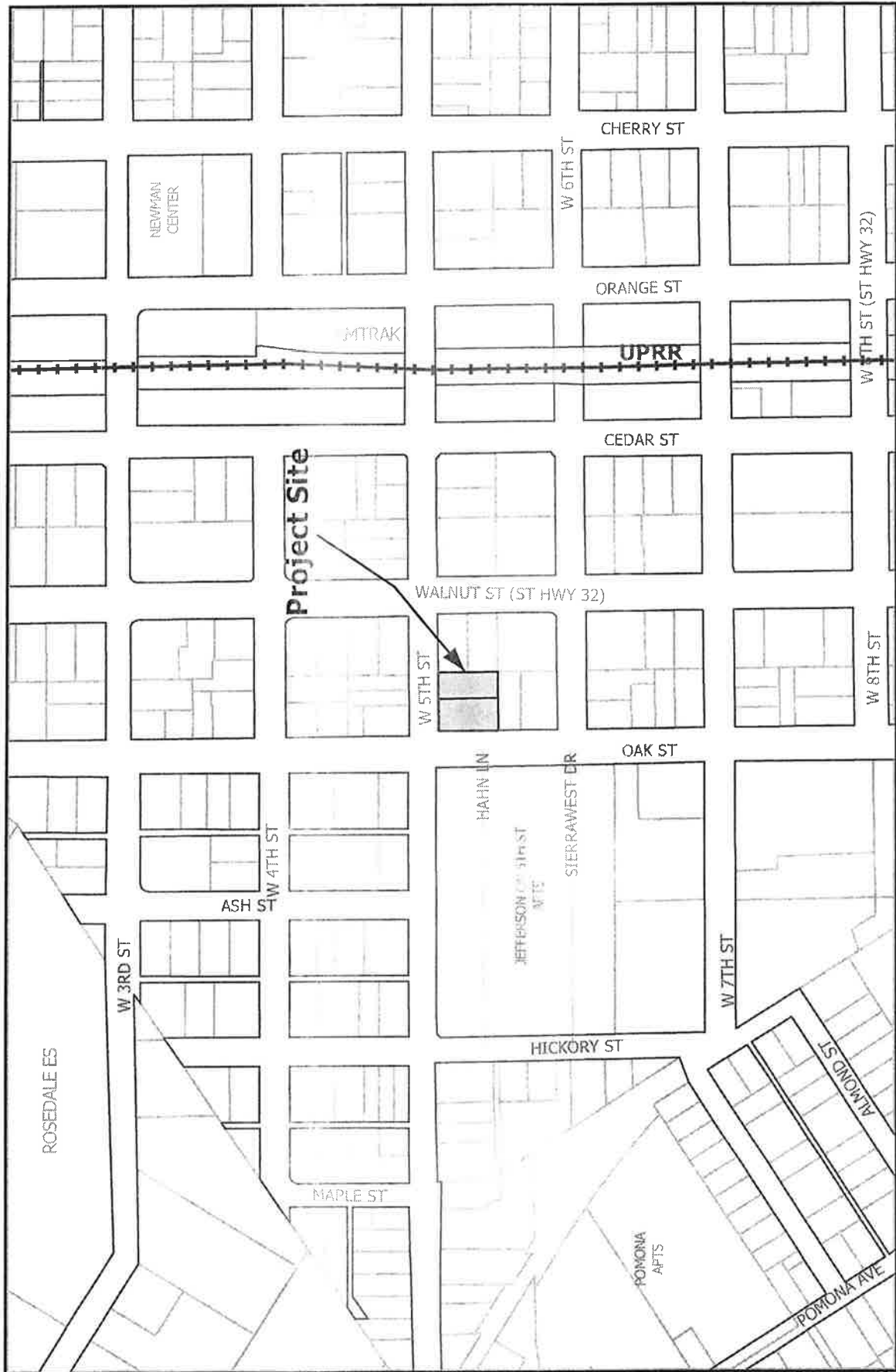

Project Site

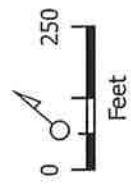

AR 15-33 (5th Street Apts)
 1131 W 5th Street
 APNs 004-201-001-000, 004-201-002-000

GREGORY A. PEITZ
ARCHITECT

383 RIO LINDO AVENUE, CHICO CA 95926 (530) 894-5719

RECEIVED

JAN 22 2016

**CITY OF CHICO
PLANNING SERVICES**

November 10, 2015

SUBJECT: REED APARTMENTS
ARHPB PROJECT DESCRIPTION

The proposed Reed Apartments is an expansion of the existing apartments that were constructed in 2012 on the adjacent lot. It is the intention of the owners to merge the two parcels and construct an exact mirror image of the existing apartments on this lot.

Like the existing apartments, each apartment has a covered front porch with adjacent yard area which reflects back to a single family type of identity and a pleasant and inviting front entrance at ground level that connects with a sidewalk directly to 5th Avenue.

Car parking is provided with a two car garage for each unit all accessed from the rear of the building. The new building will share the existing driveway that serves the existing apartments. This allows the cars and garages to not be the main visual element from the street. DG 4.1.12, DG 1.1.14

Stucco and board and batt siding are used to provide variation in the exterior textures. The roof line is broken into individual gables for each unit to provide a more interesting geometry than one large continuous mass (DG 4.1.15)

Each unit having its own garage as well as a front porch which connects to the on-street parking and public sidewalks makes each unit accessible both for the tenants and their guests. DG 4.1.52, DG 3.1.34

The air conditioning units are completely hidden from view by mounting them in a roof mechanical well. DG 3.1.35

Revision	Date	By
1	12-15-15	CS

GREGORY A. PEITZ ARCHITECT
 383 Rio Lindo Ave. Chico, CA. 95926 (530) 894-5719

5TH STREET APARTMENTS
 FOR: REED - LIBERMAN
 AT: 1131 W. 5TH STREET
 CHICO, CALIFORNIA



REED - LIBERMAN
 5TH STREET APARTMENTS

Date: OCT. 2015
 Scale:
 Draw: CAS
 Job: 14-190B
 Sheet:
ARB-1

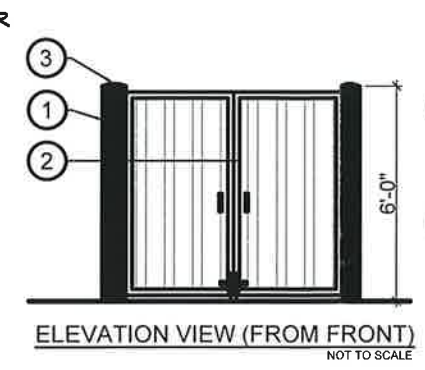
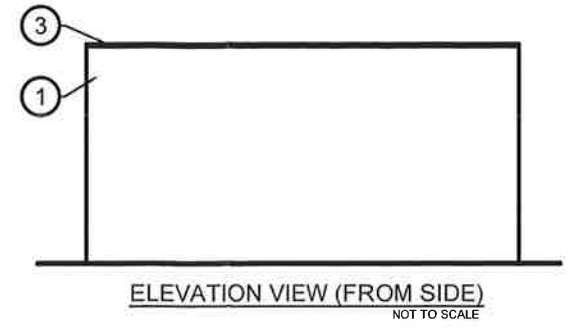
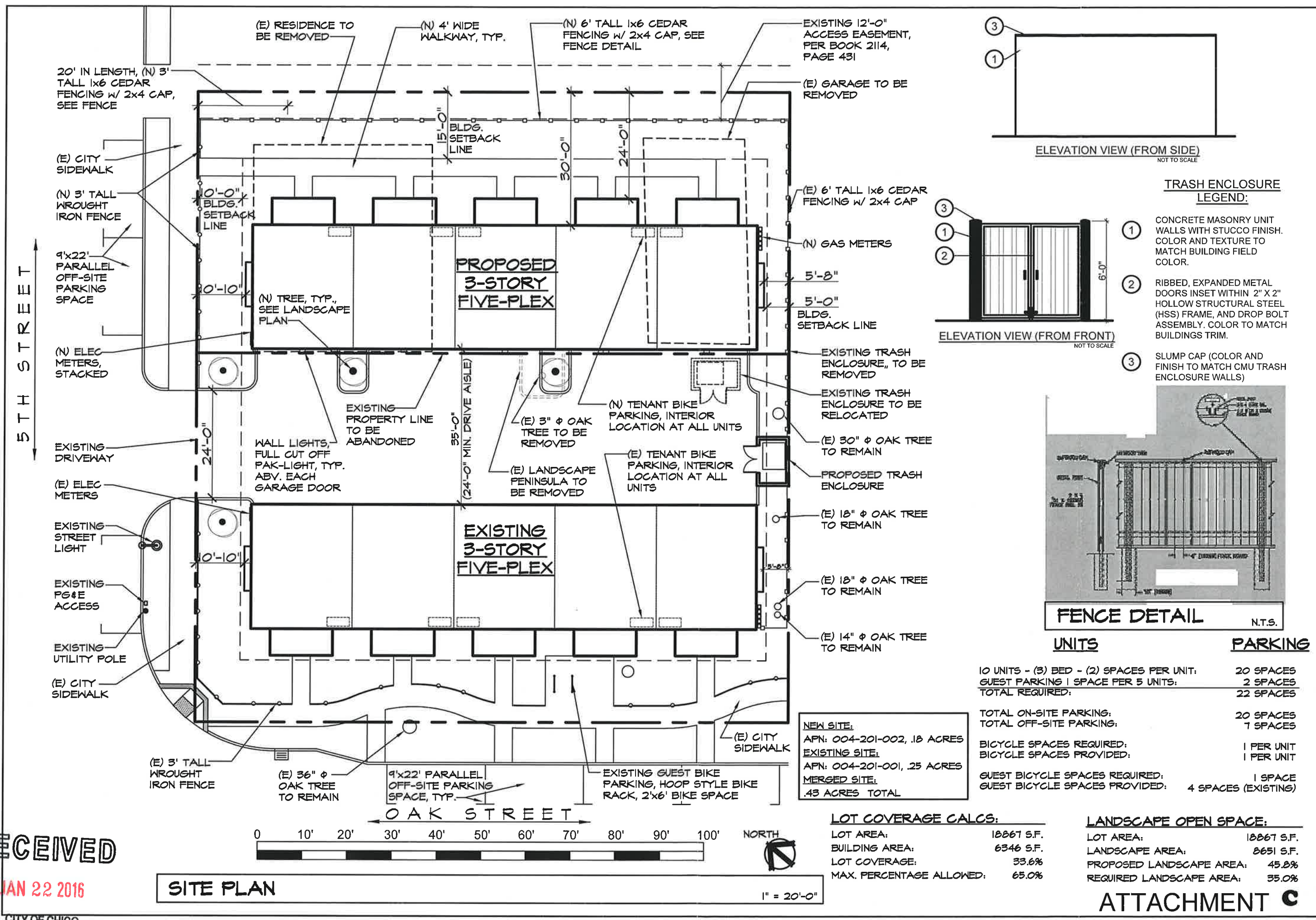

- TRASH ENCLOSURE LEGEND:**
- ① CONCRETE MASONRY UNIT WALLS WITH STUCCO FINISH. COLOR AND TEXTURE TO MATCH BUILDING FIELD COLOR.
 - ② RIBBED, EXPANDED METAL DOORS INSET WITH 2" X 2" HOLLOW STRUCTURAL STEEL (HSS) FRAME, AND DROP BOLT ASSEMBLY. COLOR TO MATCH BUILDINGS TRIM.
 - ③ SLUMP CAP (COLOR AND FINISH TO MATCH CMU TRASH ENCLOSURE WALLS)

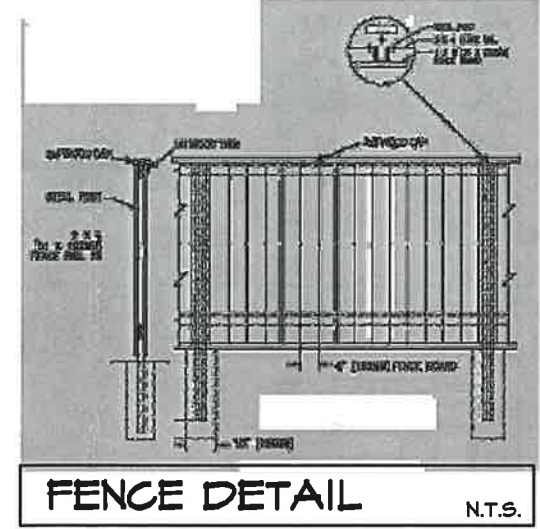

UNITS	PARKING
10 UNITS - (3) BED - (2) SPACES PER UNIT:	20 SPACES
GUEST PARKING SPACE PER 5 UNITS:	2 SPACES
TOTAL REQUIRED:	22 SPACES
TOTAL ON-SITE PARKING:	20 SPACES
TOTAL OFF-SITE PARKING:	7 SPACES
BICYCLE SPACES REQUIRED:	1 PER UNIT
BICYCLE SPACES PROVIDED:	1 PER UNIT
GUEST BICYCLE SPACES REQUIRED:	1 SPACE
GUEST BICYCLE SPACES PROVIDED:	4 SPACES (EXISTING)

NEW SITE:
 APN: 004-201-002, .18 ACRES

EXISTING SITE:
 APN: 004-201-001, .25 ACRES

MERGED SITE:
 .43 ACRES TOTAL

LOT COVERAGE CALCS:

LOT AREA:	18867 S.F.
BUILDING AREA:	6346 S.F.
LOT COVERAGE:	33.6%
MAX. PERCENTAGE ALLOWED:	65.0%

LANDSCAPE OPEN SPACE:

LOT AREA:	18867 S.F.
LANDSCAPE AREA:	8651 S.F.
PROPOSED LANDSCAPE AREA:	45.8%
REQUIRED LANDSCAPE AREA:	35.0%

RECEIVED

JAN 22 2016

CITY OF CHICO
 PLANNING SERVICES

SITE PLAN

ATTACHMENT C

12/15/2015 4:23:55 PM

Revision	Date	By
1	12-15-15	CS

GREGORY A. PEITZ
ARCHITECT
 383 Rio Lindo Ave. Chico, CA. 95926 (530) 894-5719
 Email: gregpeitz@sbcglobal.net

5TH STREET APARTMENTS
 FOR: REED - LIBERMAN
 AT: 1131 W. 5TH STREET
 CHICO, CALIFORNIA



REED - LIBERMAN
 5th STREET
 APARTMENTS

Date: OCT. 2015
 Scale:
 Drawn: CAS
 Job: 14-190B
 Sheet: **ARB-4**
 Of: _____

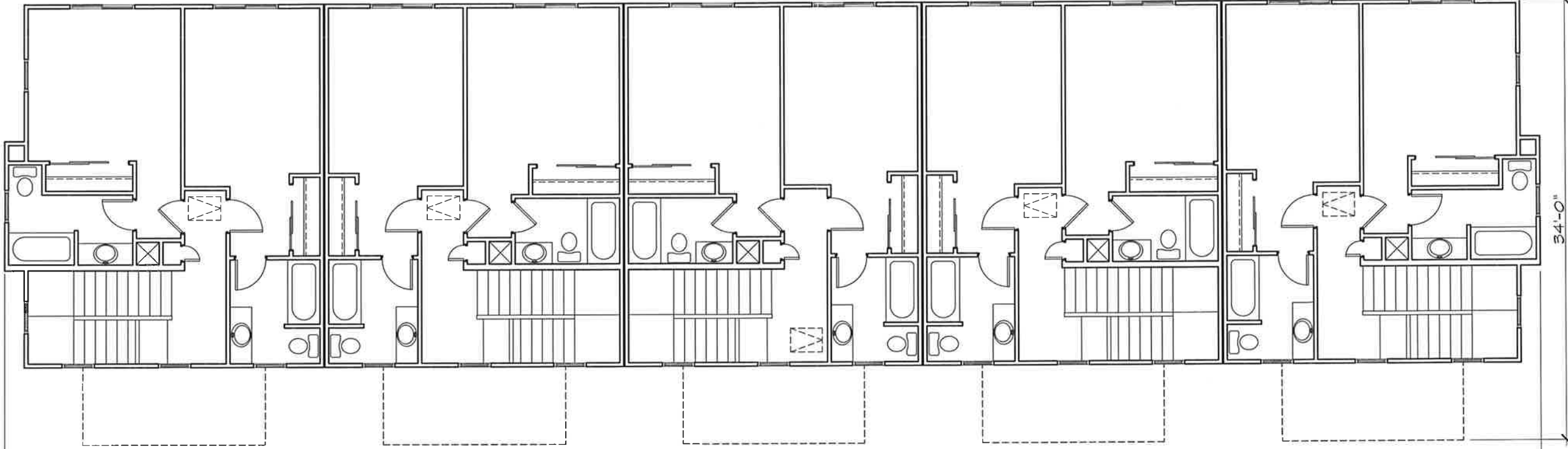

THIRD FLOOR PLAN 1/4" = 1'-0"

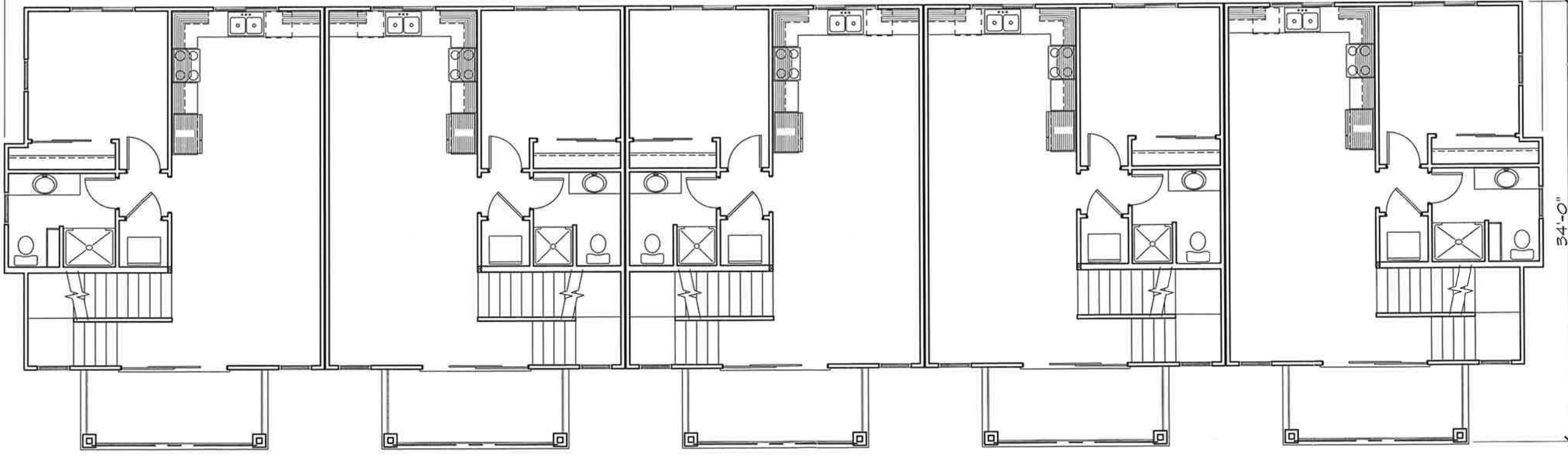

SECOND FLOOR PLAN 1/4" = 1'-0"

RECEIVED

JAN 22 2016

CITY OF CHICO
 PLANNING SERVICES

ATTACHMENT **D**

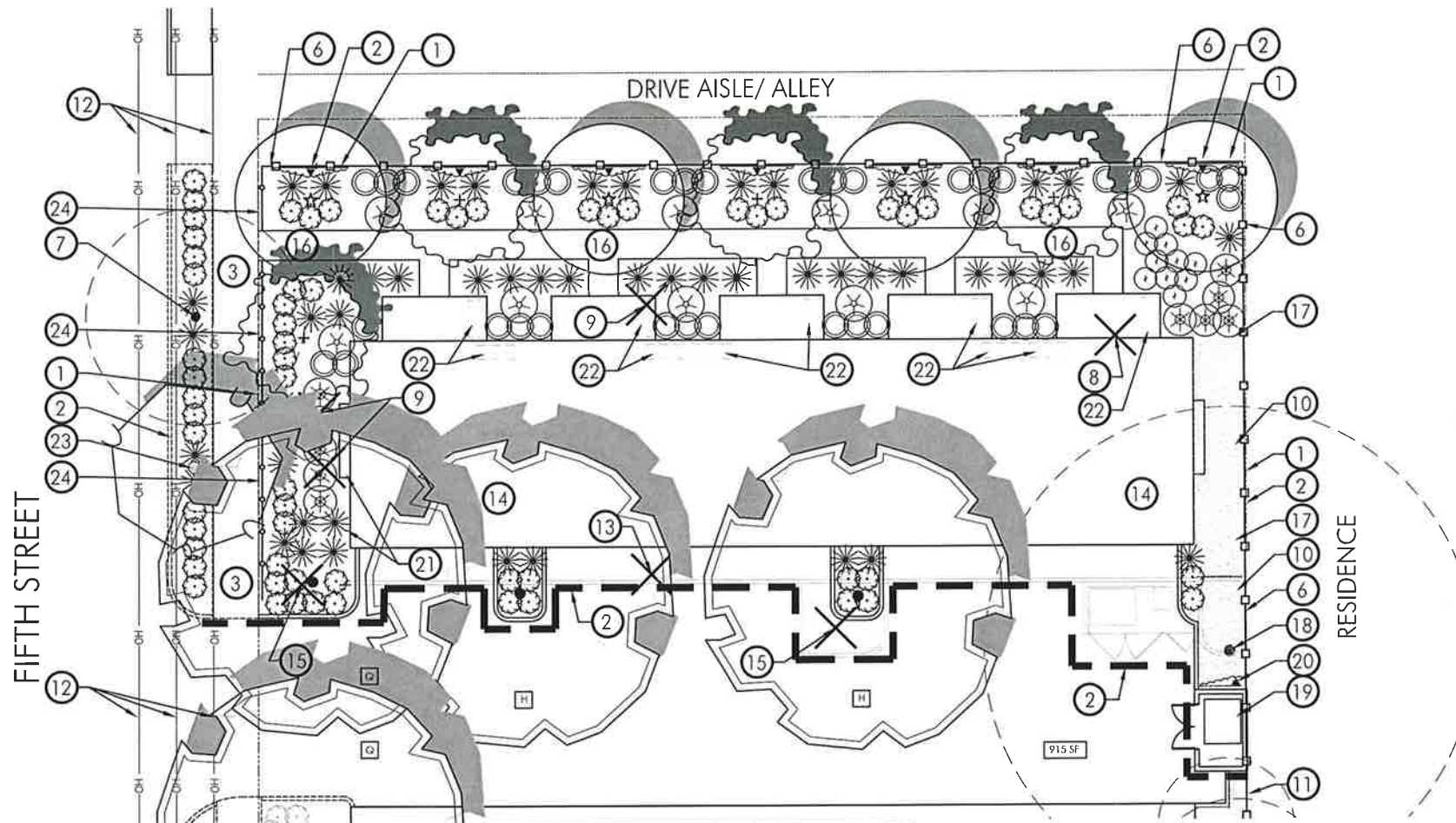

FIFTH STREET

RESIDENCE

Maximum Applied Water Allowance (MAWA) - Calculation

MAWA = (Eto) (0.7) (LA) (0.62)

MAWA = 71,372 Gallons per Year

Where:
 57.3 = Reference Evapotranspiration (Eto)
 0.7 = ET Adjustment Factor (percent)
 2,870 = Landscape Area (LA) (square feet)
 0.62 = Conversion factor (inches to gallons)

Estimated Water Use for Hydrozones (EWU) - Calculation

EWU = (Eto) (PF) (HA) (0.62) / (IE)

Where:
 57.3 = Reference Evapotranspiration (Eto) (Ref. CIMIS)
 PF = Plant Factor per Hydrozone
 HA = Hydrozone Area (square feet)
 0.62 = Conversion factor (inches to gallons)
 IE = Irrigation Efficiency per Sprinkler Type

Hydrozone	PF	HA	EWU
Hydrozone 6; Medium water use trees, shrubs and ground cover, drip.	0.5	2,870 (square feet)	0.065886 Acres
	0.9		
Total Estimated Water Use for All Hydrozones (EWU) - Sum			
	56,844 (gallons per year)	0.173635 Acre-Foot per Year	0.001736 Acres
	76 (100 cubic feet per year)		

PARKING LOT LANDSCAPE

DESCRIPTION	AREA	PERCENT
PARKING LOT PAVING	3,870 SF	
PARKING LOT LANDSCAPE	179 SF	5%

COMPLIANCE CHECKLIST

CHECK BOX	DESCRIPTION	SYMBOL
<input type="checkbox"/>	PLANTING PLAN WITH LEGEND.	(A)
<input type="checkbox"/>	STATEMENT AS TO SOILS TYPE AND ANY SPECIAL PLANTING TECHNIQUES REQUIRED.	(B)
<input type="checkbox"/>	TREES TO REMAIN OR BE REMOVED (NOTE SPECIES AND SIZE).	(C)
<input type="checkbox"/>	FENCE/ WALL LOCATIONS, HEIGHTS, DESIGNS	(D)
<input type="checkbox"/>	HARDSCAPE FEATURES AND MATERIALS.	(E)
<input type="checkbox"/>	EXTERIOR LIGHTING- LOCATION HEIGHT, DESIGN, TYPE OF LAMP, AND INTENSITY. SEE ARCHITECTS PLAN.	(F)
<input type="checkbox"/>	SCREENING METHODS FOR TRASH ENCLOSURES, MECHANICAL EQUIPMENT, AND PARKING AREAS. (SEE ARCHITECTS PLANS FOR ADDITIONAL INFORMATION)	(G)
<input type="checkbox"/>	PERCENTAGE OF PAVEMENT SHADING IN PARKING AREA (MINIMUM OF 50% REQUIRED).	(H)
<input type="checkbox"/>	OUTDOOR AMENITIES/ BREAK AREAS.	(I)
<input type="checkbox"/>	AB 1881 COMPLIANT / CONCEPTUAL HYDROZONES AND IRRIGATION METHODS.	(J)

(A) TREE LIST (MEDIUM WATER USE)

SYMBOL	LATIN NAME/ COMMON NAME	SPREAD	CONTAINER SIZE
(Symbol)	LAURUS NOBILIS SARATOGA' SARATOGA LAUREL	20'	15 GAL
(Symbol)	ARBUTUS MARINA' MARINA MADRONE	20'	15 GAL
(Symbol)	LAGERSTROEMIA INDICA 'DYNAMITE' RED FLOWERING CRAPE MYRTLE	20'	15 GAL
(Symbol)	ACER PLATANOIDES 'SUMMERSHADE' SUMMERSHADE MAPLE	40'	15 GAL

(A) SHRUB LIST (MEDIUM WATER USE)

SYMBOL	LATIN NAME/ COMMON NAME	SPREAD	CONTAINER SIZE
(Symbol)	PINUS MUGO 'MUGO' DWARF MUGO PINE	8'	15 GAL
(Symbol)	PYRACANTHA COCCINEA 'LOWBOY' LOWBOY PYRACANTHA	3'	1 GAL
(Symbol)	NANDINA DOMESTICA 'COMPACTA' COMPACT HEAVENLY BAMBOO	3'	1 GAL
(Symbol)	DIETES BICOLOR FORTNIGHT LILY	3'	1 GAL
(Symbol)	ROSA 'NOARE' P.P.# 1130B FLOWER CARPET® RED GROUNDCOVER ROSE	3'	1 GAL
(Symbol)	MAHONIA REPENS CREEPING MAHONIA	2'	1 GAL
(Symbol)	PARthenocissus TRICUSPIDATA VETCHII BOSTON IVY		1 GAL

VICINITY MAP

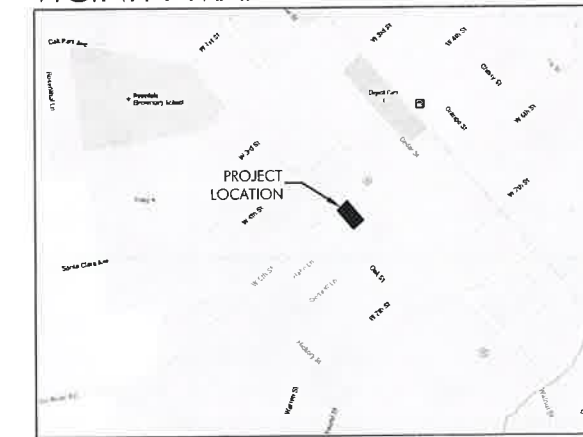

PLAN LEGEND

SYMBOL	DESCRIPTION
(1)	PROPERTY LINE
(2)	LIMIT OF WORK
(3)	EXISTING CITY SIDEWALK
(4)	EXISTING POWER POLE
(5)	EXISTING CITY OF CHICO STREET LIGHT
(6)	6' HIGH WOOD FENCE (3' HIGH TO 20' FROM FACE OF CURB)
(7)	EXISTING CITY STREET TREE TO REMAIN
(8)	EXISTING CEDAR TREE TO BE REMOVED (TRUNKS AND CANOPIES DRAWN TO SCALE- 30" DBH)
(9)	EXISTING ITALIAN CYPRESS TREES TO BE REMOVED (TRUNKS AND CANOPIES DRAWN TO SCALE- 18", 18", & 24" DBH)
(10)	6"-8" DIAMETER RIVER COBBLE OVER WEED BARRIER
(11)	EXISTING 6' HIGH WOODEN FENCE (TO REMAIN)
(12)	OVERHEAD LINES
(13)	EXISTING ALANTHUS TREE TO BE REMOVED (TRUNK AND CANOPY DRAWN TO SCALE- 12" DBH)
(14)	HVAC LOCATIONS: ROOF MOUNTED SEE ARCHITECTS PLANS
(15)	EXISTING CORK OAKS, TO BE REMOVED (TRUNKS AND CANOPIES DRAWN TO SCALE)
(16)	CONCRETE SIDEWALK
(17)	REDWOOD HEADER
(18)	EXISTING VALLEY OAK TO REMAIN. (TRUNK AND CANOPY DRAWN TO SCALE- 30" DBH)
(19)	TRASH ENCLOSURE. SEE ARCHITECTS PLANS.
(20)	VINE TRAINED TO TRASH ENCLOSURE WALLS
(21)	UTILITIES. SEE ARCHITECTS PLANS.
(22)	BICYCLE PARKING (INVERTED 'U' STYLE, 2 BIKE CAPACITY) TYPICAL AT EACH FRONT PORCH
(23)	CITY STREET TREE INSTALL WITH ROOT BARRIERS AND SOIL SET TREE GUARDS, TYPICAL AT ALL NEW CITY STREET TREES.
(24)	3' HIGH WROUGHT IRON FENCE MATCH EXISTING.

(G) SHADE CALCULATIONS

DESCRIPTION	SHADE AREA	QUANTITY	TOTAL	PERCENT
TOTAL PARKING AND BACK-UP AREA			3,870 SF	
SHADE AREA PROVIDED				
SUMMERSHADE MAPLE				
(F) FULL	706 SF	0	0	0
(H) THREE QUARTER	530 SF	0	0	0
(I) HALF	353 SF	2	706 SF	18%
(J) QUARTER	177 SF	2	353 SF	9%
EXISTING TREE SHADE				
(915 SF)			915 SF	24%
TOTAL SHADE AREA PROVIDED			1,974 SF	51%

TREE MITIGATION

TREE SPECIES	DIAMETER	MITIGATION REQUIREMENT
QUALIFYING TREES		
INCENSE CEDAR	30"	YES
ITALIAN CYPRESS	24"	YES
ITALIAN CYPRESS	18"	YES
ITALIAN CYPRESS	18"	YES
TOTAL DBH OF QUALIFYING TREES		90"
MITIGATION TREES REQUIRED (1 FOR EVERY 6" DBH)		15
7 MITIGATION TREES PROVIDED ON SITE, IN LIEU FEES FOR 8 OFF-SITE TREES REQUIRED		
NON-QUALIFYING TREES		
ALANTHUS	12"	NO
CORK OAK	3"	NO
CORK OAK	3"	NO

(B) SOILS STATEMENT

THIS SITE IS LOCATED IN A REGION FREE OF TUSCAN FORMATIONS AND LAVA CAPS. SITE SOILS ARE OF SUPERIOR QUALITY. STANDARD SOIL AMENDMENTS WILL BE APPLIED.

BARK MULCH

A UNIFORM 2" MINIMUM LAYER OF WALK-ON FIR BARK MULCH SHALL BE APPLIED TO ALL LANDSCAPE AREAS (EXCEPT FOR TURF AREAS AND AREAS TO RECEIVE RIVER COBBLE GROUNDCOVER).

(I) LANDSCAPE IRRIGATION

ALL LANDSCAPED AREA (2,870 SF) IS HYDROZONED AS MEDIUM WATER USE AND SHALL BE IRRIGATED BY MEANS OF AN AUTOMATICALLY CONTROLLED, LOW VOLUME DRIP IRRIGATION SYSTEM. USING THE WATER BUDGET CALCULATIONS PER AB 1881 REQUIREMENTS (SHOWN TO THE RIGHT), IT HAS BEEN DETERMINED THAT THE ESTIMATED WATER USE (EWU) OF THE PROPOSED LANDSCAPE IS 56,844 GALLONS PER YEAR AND DOES NOT EXCEED THE MAXIMUM APPLIED WATER ALLOWANCE (MAWA), WHICH IS 71,372 GALLONS PER YEAR.

FIFTH AT OAK 5-PLEX

PRELIMINARY LANDSCAPE PLAN

RECEIVED

JAN 22 2016

Prepared for:
REED LIEBERMAN LLC
 P.O. BOX 3193
 CHICO, CALIFORNIA 95927

**CITY OF CHICO
 PLANNING SERVICES**

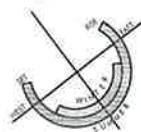

SOLAR INFLUENCE



BAR SCALE

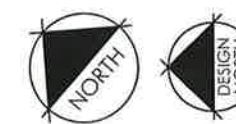

SCALE: 1"= 10'-0"

Prepared by:

DATE: DECEMBER 9, 2015
 PROJECT NUMBER: 1865
 DRAWN: JBB

BRIAN FIRTH LANDSCAPE ARCHITECT, INC.
 627 BROADWAY, SUITE 220, CHICO, CALIFORNIA 95928
 PHONE: (530) 899-1130 / FAX: (530) 899-1920
 www.BFLAdesign.com www.facebook.com/BFLAdesign

ATTACHMENT E



FRONT (EAST)

**REED -
LIEBERMAN
5th STREET
APARTMENTS**



BACK (WEST)



SIDES (NORTH & SOUTH)

RECEIVED

JAN 22 2016

CITY OF CHICO
PLANNING SERVICES

ATTACHMENT **F**

Project	Date	By
	12-15-15	CS

GREGORY A. PEITZ ARCHITECT
 383 Rio Lindo Ave. Chico, CA. 95926 (530) 894-5719
 Email: gregpeitz@sbglobal.net

RECEIVED

5TH STREET APARTMENTS
 FOR: REED - LIBERMAN
 AT: 1131 W. 5TH STREET
 CHICO, CALIFORNIA

REED - LIBERMAN 5th STREET APARTMENTS

DATE: OCT. 2015
 Scale: CAS
 Job: 14-190B
 Sheet: ARB-2

JAN 22 2015

CITY OF CHICO
 PLANNING SERVICES

12/15/2015 4:23:58 PM



TRIANGLE GABLE VENT

REAR ELEVATION

1/4" = 1'-0"

WALL LIGHTS, FULL CUT OFF PAK-LIGHT, TYP. ABV. EACH GARAGE DOOR



FRONT ELEVATION

1/4" = 1'-0"

ATTACHMENT **F**

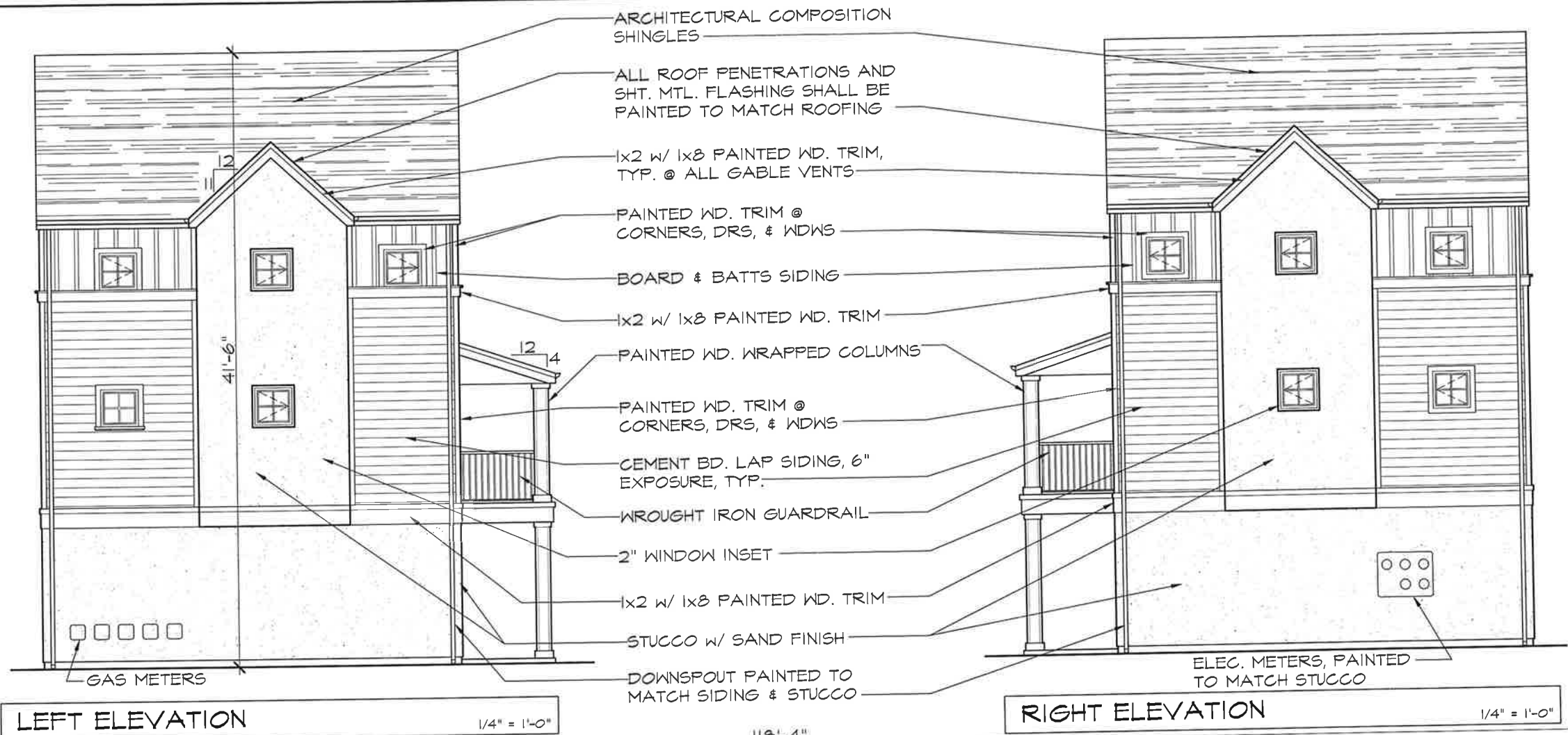

LEFT ELEVATION

RIGHT ELEVATION

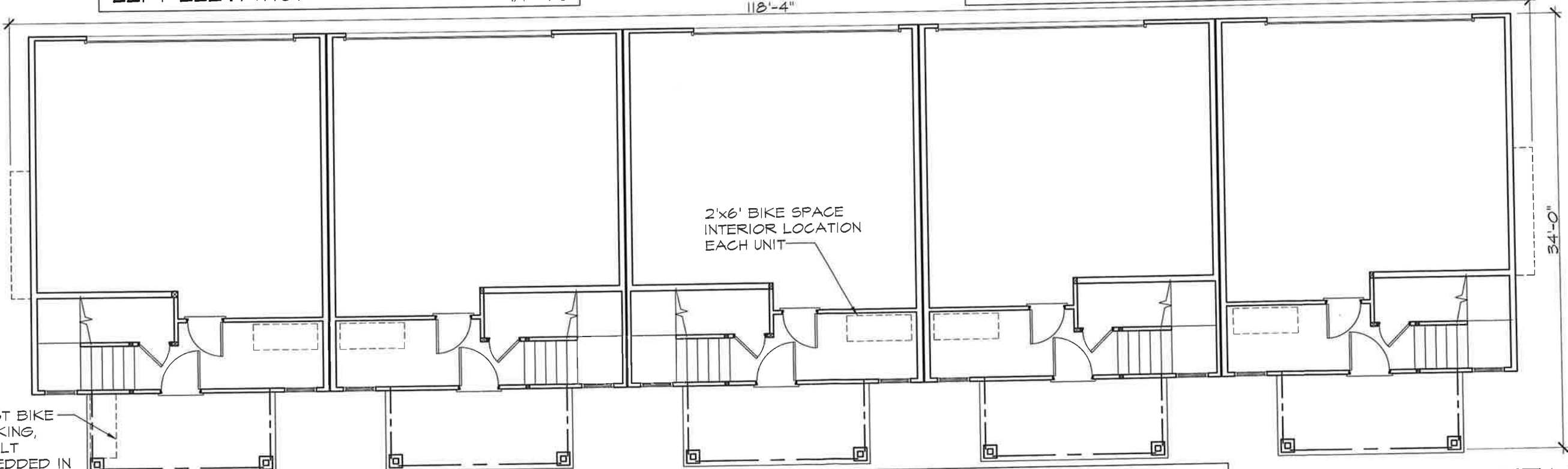

FIRST FLOOR PLAN

ATTACHMENT F

Revision	Date	By
1	12-15-15	CAS

GREGORY A. PEITZ
ARCHITECT
 383 Rio Lindo Ave. Chico, CA. 95926 (530) 894-5719
 Email: gregpeitz@sbcglobal.net

5TH STREET APARTMENTS
 FOR: REED - LIBERMAN
 AT: 1131 W. 5TH STREET
 CHICO, CALIFORNIA

RECEIVED

JAN 22 2016

CITY OF CHICO



REED - LIBERMAN
 5TH STREET APARTMENTS

DATE: OCT. 2015
 SCALE:
 DRAWN: CAS
 JOB: 14-190B

ARB-3



ATTACHMENT G

5th STREET 5-PLEX

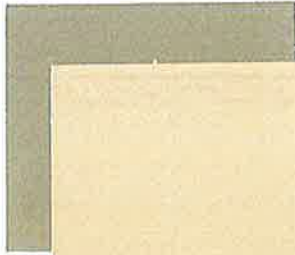

WINDOW & DOOR STUCCO TRIM -
KELLY MOORE - "VILLITA" 196



STUCCO COLOR -
KELLY MOORE - "CHARRO" 228



WINDOW & DOOR STUCCO TRIM -
KELLY MOORE - "SALTILLO" 212



CEMENT BOARD SIDING -
KELLY MOORE - "CHARRO" 228



CORNER, WINDOW & DOOR TRIM -
KELLY MOORE - "SALTILLO" 212



BOARD & BATTS -
KELLY MOORE - "VILLITA" 196



GUTTER, FASCIA, ATTIC VENT -
KELLY MOORE - "SALTILLO" 212



ROOFING -
COMPOSITION SHINGLES

RECEIVED

JAN 22 2016

CITY OF CHICO
PLANNING SERVICES

ATTACHMENT H

PATRIOT WALL SCONCE (Various reflectors are protected by U.S. Patent No. 6,464,378.)



Flat-lensed fixtures meet IESNA full cutoff classification
 COMMUNITY FRIENDLY

DIMENSIONS

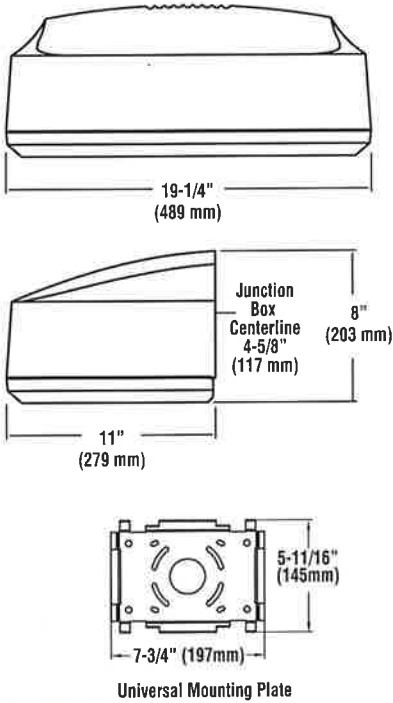

RECEIVED

JAN 22 2016

**CITY OF CHICO
 PLANNING SERVICES**

SHIPPING WEIGHTS - Patriot Wall Sconce

Catalog Number	Est. Weight (kg/lbs.)	Length (mm/in.)	Width (mm/in.)	Height (mm/in.)
PTWS-HID	11/25	616/24.25	394/15.5	362/14.25
PTWS-CFL	9/20	616/24.25	394/15.5	362/14.25

HOUSING - The one-piece die-cast aluminum housing is a multi-radiused rectangular shape. All mounting hardware is stainless steel or electro-zinc plated steel.

WALL MOUNT - A galvanized-steel universal wall mounting plate easily mounts directly to a 4" octagonal or square junction box. An EPDM gasket is supplied to be installed between the mounting plate and junction box, sealing the junction box from entrance of water. The galvanized-steel universal plate allows the fixture to be suspended while making wiring connections. A unique clamping design securely locks the fixture to the wall mounting plate by utilizing two hex head screws. The universal plate permits the fixture to be mounted in the uplighting or downlighting position. Both positions are listed for wet locations. The standard housing/door seal design prevents external contaminants from entering the PTWS, resulting in an IP65 rating.

DOOR FRAME - The die-cast aluminum door frame with two black stainless steel captive fasteners allows easy access into the fixture. A one piece extruded silicone closed-cell sponge gasket seals the door frame against the housing. The door hinges open for ease of lamp and ballast maintenance.

LENS/GASKET - A flat clear tempered glass lens is sealed to the door frame with silicone closed-cell sponge gasketing.

SOCKETS - HID lampholders are glazed porcelain, medium base, 4KV pulse rated. The Compact Fluorescent fixtures feature a one-piece thermoplastic socket.

LIGHT SOURCES - The fixture is designed to operate with horizontal Ceramic Metal Halide, Metal Halide, High Pressure Sodium, and single or double Compact Fluorescent lamps. Lamps supplied as standard – HID (clear, shipped installed), and Compact Fluorescent (coated, 4100K, not installed).

BALLASTS/ELECTRICAL COMPONENTS

- Electrical components are factory-mounted in housing and prewired with voltage specific leads which extend out the back of the unit through a rubber grommet. This grommet prevents the entry of insects, dust, and moisture into the fixture. The need to open the fixture to make wiring connections is eliminated, thus making installation quick and easy. UL listed HID components with high-power factor ballasts rated for -20° F starting. Compact Fluorescent ballasts are Electronic Universal Voltage (120-277V, 50/60Hz) or 347V (60Hz), 0° F starting. Compact Fluorescent fixtures with UE (Universal Electronic) voltage are available with an optional dimming ballast for multiple types of controls such as building lighting controls and occupancy sensors. Available battery back-up of BB (32° starting temperature) and CWBB (0° starting temperature) are 120 or 277 voltage specific for U.S. applications for 26 watt through 42 watt lamps. Consult factory for available wattages and voltages for use in Canada

EMERGENCY OPERATION - A variety of integral emergency options are available to comply with Life Safety Codes which require emergency lighting along the path of egress on the building's exterior, so building occupants can exit safely. Integral Emergency Battery Back-up options are available on Compact Fluorescent units. Emergency Quartz options are offered on HID units. Options for one or two 12 volt separate circuit(s), for use with up to 35 watt Halogen lamp(s) are available on both Compact Fluorescent and HID units.

REFLECTORS/DISTRIBUTION PATTERNS

- Forward Throw (FTM, FT), Type III (3), and Wall Wash (WW) reflectors are available. All are high performance, full cut-off distribution as defined by the IESNA (downlight position only). Photometric data is tested in accordance with IESNA guidelines.

FINISHES - Each fixture is finished with LSI's DuraGrip® polyester-powder finishing process. The DuraGrip finish withstands extreme weather changes without cracking or peeling and is guaranteed for five full years. Standard colors include bronze, black, platinum plus, white, satin verde green, metallic silver, and graphite.

PHOTOMETRICS - Please visit our web site at www.lsi-industries.com for detailed photometric data.



IP65

ARRA
 Funding Compliant



Project Name _____ Fixture Type _____
 Catalog # _____