



Architectural Review
and Historic Preservation Board
Agenda Report

Meeting Date 11/16/16

DATE: November 7, 2016

File : AR 16-24

TO: Architectural Review and Historic Preservation Board

FROM: Mike Sawley, AICP, Associate Planner, (879-6812, mike.sawley@chicoca.gov)
Community Development Department

RE: Parkside Tap House CSP, 115 W. 3rd Street, APN 004-151-004 and -003
Southwest Corner of West 3rd and Main Streets

SUMMARY AND RECOMMENDATION

The applicant is proposing a Comprehensive Sign Program (CSP) for the new Parkside Tap House restaurant and existing television studios, located at 115 W. 3rd Street and 300 Main Street, respectively, in Downtown Chico. New signs associated with the CSP include a non-illuminated projecting sign near the street intersection and a cabinet sign placed over a gateway feature located in a private alleyway off W. 3rd Street. Staff recommends that the Architectural Review and Historic Preservation Board adopt the required findings contained in the agenda report and approve the CSP, subject to the recommended conditions.

Proposed Motion

I move that the Architectural Review and Historic Preservation Board adopt the required findings contained in the agenda report and approve Architectural Review 16-24 (Parkside Tap House CSP), subject to the recommended conditions.

BACKGROUND

The applicant proposes to install two signs near the southwest corner of 3rd and Main Streets in Downtown Chico (see **Attachment A**, Location Map). The site is zoned DN-L-COS (Downtown North with Landmark and Corridor Opportunity Site overlays), and designated Commercial Mixed Use by the General Plan.

Currently under construction, the new Parkside Tap House restaurant will share the ground-floor of the building located at 300 Main Street with existing television studios that front along Main Street (see **Attachment B**, Site Plan). The restaurant will occupy the western portion of the ground floor, and will have an outdoor seating area located in the private alleyway between the restaurant and *Powell's Sweet Shoppe* located at 121 W. 3rd Street. The minor external changes associated with the restaurant (converting the private alleyway to outdoor seating and adding a fence/gate feature), were approved administratively earlier this year.

The applicant requests approval of two signs, as follows:

1. A projecting wall sign ("Sign A") that would be mounted at the corner of the building at the intersection of 3rd and Main Streets (see **Attachment C**, Sign A Details). The sign would have two faces and would not be illuminated. Sign A would be 18- to 36-inches in width; eight feet, nine inches in height; and mounted 13 feet above the public sidewalk. Sign construction would be powder-coated black aluminum, with white plastic letters and logo displaying the restaurant's theme (Bidwell Park).

2. A cabinet sign (“Sign B”) that would be integrated into a gateway feature that controls access to the outdoor beer garden area (see **Attachment D**, Sign B Details). The sign would have one internally illuminated face. It would be eight feet, eight inches wide; 28-inches in height; and mounted eight feet, six inches above the ground (six inches above a large gate). Also powder-coated black aluminum, the sign would have cutout letters with vinyl backing to create white illuminated letters displaying the restaurant name at night.

DISCUSSION

The two new signs are complementary in that the corner projecting sign would be mounted high on the building to enhance the new restaurant’s visibility to the general public, and the gateway sign would help patrons find the restaurant’s entrance area, which is set back from 3rd Street and shielded from Main Street by buildings.

The proposed signs would add approximately 73 square feet to the existing 65 square feet of signage at the site for a total of 138 square feet (see **Attachment E**, Sign Areas). This would remain below the maximum allowable sign area of 200 square feet for the overall site.

Board approval is required for Sign A as part of the CSP because projecting signs are typically limited to 8 square feet (4 square feet per face). Although Sign A is shown on the drawings as having 26.25 square feet per face, the area containing the copy and logo is less than 16 square feet. Sign A would also be located above the sill of the second-story windows on the building, which requires Board approval.

Board approval is required for Sign B because internally illuminated cabinet signs require Board approval within the Downtown area.

Two General Plan policies specifically apply to new signs within the Downtown area. The proposed signs will aid wayfinding to the restaurant for pedestrians and motorists, consistent with Action DT-6.3.1 which encourages signs in the Downtown that help residents and visitors navigate and find their destinations. The other General Plan policy applicable to project signage encourages the use of the City’s Design Guidelines (DGs) when evaluating signs in the Downtown (DT-3.1.1).

The following Design Guidelines apply to the proposed signs:

- DG 1.3.51 Reflect the building’s architectural characteristics, while effectively presenting the business’s image.*
- DG 1.3.52 Prioritize lower placed signs (below street tree canopies when appropriate) rather than higher placed signs.*
- DG 1.3.53 Prioritize awning signs, and under awning, pedestrian-oriented signs.*
- DG 1.3.54 Prioritize individually mounted letters and symbols that are indirectly or individually illuminated rather than plastic-faced, backlit, metal cabinet signs.*

Prioritize light colored letters and graphic details when internally illuminated signs are proposed, over dark letters on light colored fields.

- DG 1.6.11 Enhance a project's identity, while protecting the character of residential neighborhoods, business areas, streetscapes, and vistas.*
- DG 1.6.12 Maintain consistency in size, material, and location within each development.*
- DG 1.6.13 Shade, shield, subdue, or direct illumination of signs so that the light intensity will not negatively impact surrounding properties or night skies.*
- DG 1.6.14 Enhance the building and do not dominate the elevation with signage.*
- DG 1.6.15 Incorporate modest-sized lettering, in accordance with Code, when using signage on an awning.*
- DG 1.6.16 Pedestrian-scaled monument signs on bases are preferred over pole-mounted varieties.*

The proposal is consistent with DGs encouraging signage that enhances a project's identity, while also respecting the building's architecture and character of the nearby streetscape (DGs 1.3.51 and 1.6.11). The project is also consistent with DGs that call for signs and lettering of modest size that do not dominate the building's elevation (DGs 1.6.14 and 1.6.15). Consistent with DGs 1.3.54, 1.6.12, and 1.6.13, the signs create contrast by using light-colored letters over dark/opaque fields, similar to existing signs on the building, and the potential for illumination from the new signs to affect off-site properties is negligible.

The proposed sign package is somewhat consistent with DGs 1.3.52 and 1.3.53, in that it prioritizes lower placed signs by only illuminating the pedestrian-level gateway sign, and DG 1.6.16 in that the gateway sign would be integrated into a decorative fence feature.

Overall, the style and placement of the proposed signs is compatible with the existing building and uses, and will heighten visibility and enhance wayfinding for the new restaurant. Staff recommends approval of the project.

REQUIRED FINDINGS FOR APPROVAL

Environmental Review

The project has been determined to be categorically exempt pursuant to the California Environmental Quality Act (CEQA) Guidelines Section 15303 (New Construction or Conversion of Small Structures). Consistent with this exemption, the project consists of the placement of signs that are appurtenant to a restaurant use, not involving the use of significant amounts of hazardous substances, where all necessary public services are available, and the surrounding area is not environmentally sensitive.

Architectural Review

According to the Chico Municipal Code Section 19.18.060, the Architectural Review and Historic Preservation Board shall determine whether or not a project adequately meets adopted City standards and design guidelines, based upon the following findings:

1. *The proposed development is consistent with the General Plan, any applicable specific plan, and any applicable neighborhood or area plans.*

The proposed signs are a minor addition to an existing commercial site in Downtown Chico. The proposed signs will aid wayfinding to the restaurant for pedestrians and motorists, consistent with Action DT-6.3.1, and the City's Design Guidelines have been applied to the project as directed by policy DT-3.1.1. No aspects of the proposed signs have been identified as inconsistent with the General Plan. The site is not included in the City's Historic Inventory or located within a Neighborhood Plan or area plan.

2. *The proposed development, including the character, scale, and quality of design are consistent with the purpose/intent of this chapter and any adopted design guidelines.*

The signs reflect a high-quality design, are appropriately scaled, and will support a desirable land use in that they would promote a new visitor-oriented restaurant use at a site, increasing attractiveness to Downtown patrons. The proposal is consistent with Design Guidelines that encourage signage that enhances a project's identity, while also respecting the building's architecture and character of the nearby streetscape (DGs 1.3.51 and 1.6.11). The project is also consistent with DGs that call for signs and lettering of modest size that do not dominate the building's elevation (DGs 1.6.14 and 1.6.15). Consistent with DGs 1.3.54, 1.6.12, and 1.6.13, the signs create contrast by using light-colored letters over dark/opaque fields, similar to existing signs on the building, and the potential for illumination from the new signs to affect off-site properties is negligible. The sign package is consistent with DGs 1.3.52 and 1.3.53, in that it prioritizes lower placed signs by only illuminating the pedestrian-level gateway sign, and DG 1.6.16 in that the gateway sign would be integrated into a decorative fence feature.

3. *The architectural design of structures, including all elevations, materials and colors are visually compatible with surrounding development. Design elements, including screening of equipment, exterior lighting, signs, and awnings, have been incorporated into the project to further ensure its compatibility with the character and uses of adjacent development.*

The design, materials and colors of the proposed new signs are visually compatible with the existing building and surrounding buildings, specifically regarding the use of light-colored letters over an opaque field, similar to existing cabinet signs on the building. Electrical wiring for the new cabinet sign will properly be screened through concealment within the support posts for the gateway feature.

4. *The location and configuration of structures are compatible with their sites and with surrounding sites and structures, and do not unnecessarily block views from other structures or dominate their surroundings.*

No new structures are proposed. The proposed CSP consists of two new signs that are appropriately scaled for the locations where they are proposed and will not unnecessarily block views or cause the site to dominate its surroundings.

5. *The general landscape design, including the color, location, size, texture, type, and coverage of plant materials, and provisions for irrigation and maintenance, and protection*

of landscape elements, have been considered to ensure visual relief, to complement structures, and to provide an attractive environment.

The proposal consists of two new signs, neither of which are freestanding signs, therefore no landscaping is proposed or required in conjunction with the project. A limited amount of landscaping, unrelated to the project signs, will be included in the outdoor beer garden area for the restaurant use.

Comprehensive Sign Program Findings

According to the Chico Municipal Code Section 19.74.070, in approving a Comprehensive Sign Program, the Architectural Review and Historic Preservation Board shall determine whether or not a project adequately meets all of the following findings in addition to those required by Chapter 19.18:

1. *The proposed Comprehensive Sign Program is consistent with the purpose and intent of this chapter;*

The proposal effectively uses flexibility allowed by the CSP process by using signs that are well-designed, aesthetically pleasing, and balance providing a reasonable amount of offsite signage with basic wayfinding to the restaurant. The projecting sign would be on the same building containing the restaurant use, though placed nearer to the street intersection to effectively communicate the restaurant's location to the public.

2. *The signs are visually related to other signs included in the Comprehensive Sign Program and to the structure and/or developments they identify and to surrounding development;*

The new signs visually relate to the existing signs at the site in that both styles display messages using light-colored letters and logos over an opaque black field. Both new signs use contrasting, compatible colors to communicate the restaurant's theme, and the cabinet sign would be integrated into a uniquely identifiable gateway feature.

3. *The Comprehensive Sign Program accommodates future revisions which may be required due to changes in use or tenants; and*

Conditions have been included to accommodate future changes to the sign program, specifying that staff may administratively approve substitutions of similar signs or new signs that meet code requirements for the zoning district.

4. *The Comprehensive Sign Program complies with all of the standards of this chapter, including the maximum overall sign area allowable, except that flexibility is allowed with regard to individual sign area, number, location, and/or height to the extent that the Comprehensive Sign Program will enhance the overall development and will more fully accomplish the purposes of this chapter.*

The sign program complies with the standards of CMC 19.74, including allowing less than the maximum overall sign area of 200 square feet. Illumination of the cabinet sign in the private alley will be set back from 3rd Street and not negatively affect nearby properties.

Flexibility is allowed with regard to location and individual area of the projecting sign, which meets the purpose of a comprehensive sign program by enhancing the visibility of a new restaurant use that would otherwise be limited by surrounding buildings.

RECOMMENDED CONDITIONS OF APPROVAL

1. All approved building plans and permits shall note on the cover sheet that project signage shall comply with AR 16-24 (Parkside Tap House CSP). No building permits related to this approval shall be finalized without authorization of Planning staff.
2. The signs approved under this Comprehensive Sign Program are shown on the accompanying drawings date-stamped October 28, 2016, by the Planning Services Division and include the following:

Signs for 115 W. 3rd Street

- a. Sign A: a non-illuminated projecting sign mounted at the corner of the building at the intersection of 3rd and Main Streets. Sign A is 18- to 36-inches in width; eight feet, nine inches in height; and mounted 13 feet above the public sidewalk. Sign A is powder-coated black aluminum, with white plastic letters and/or logos.
- b. Sign B: an internally-illuminated cabinet sign integrated into a gateway feature that controls access to the outdoor seating area located in the private alleyway between 115 and 121 W. 3rd Street. Sign B is eight feet, eight inches wide; 28-inches in height; and mounted eight feet, six inches above the ground (six inches above a large gate). Sign B is powder-coated black aluminum, with cutout letters with vinyl backing to create illuminated letters.

Signs for 300 Main Street

- c. Sign C: an internally illuminated cabinet sign facing Main Street, 28 square feet in size. Sign C is a black aluminum cabinet with a plastic face composed of black opaque negative area and light-colored letters/logos.
- d. Sign D: an internally illuminated cabinet sign facing W. 3rd Street, 28 square feet in size. Sign D is a black aluminum cabinet with a plastic face composed of black opaque negative area and light-colored letters/logos.
- e. Sign E: internally illuminated cabinet sign facing Main Street, 9 square feet in size, with red semi-opaque negative area and light-colored letters/logos.

Signs under this approval may be substituted over time with new signs of substantially the same style, or any new sign that meets typical sign code requirements for the district.

Also, additional signs that conform to code requirements for the district may be authorized by staff, provided that the new signs add 30 square feet or less to the total signage for either address and do cause total signage at the site to exceed the maximum code allowance.

3. All approved building plans and permits shall note that exposed conduit, mounting brackets, flashing, and similar visible hardware and appurtenances shall be painted using appropriate colors. Adequate finishing details for the sign installation shall be verified by Planning staff prior to permit final.

PUBLIC CONTACT

Public notice requirements are fulfilled by placing a notice on the project site and by posting of the agenda at least 10 days prior to the ARHPB meeting.

ATTACHMENTS

- A. Location Map
- B. Site Plan
- C. Sign A Details
- D. Sign B Details
- E. Sign Areas

DISTRIBUTION (4)

Bob Summerville, Senior Planner

Mike Sawley, Associate Planner

Parkside Tap House, Attn: Josh Snider, 115 3rd. Street, Chico, CA 95928

Tom Van Overbeek, 3 Miguelita Road, San Jose, CA 95127

Files: AR 16-24 (Parkside Tap House CSP)

X:\Current Planning\AR\2016\24 Parkside Tap House CSP\ARHPB report 11-16-16.doc

SITE PLAN

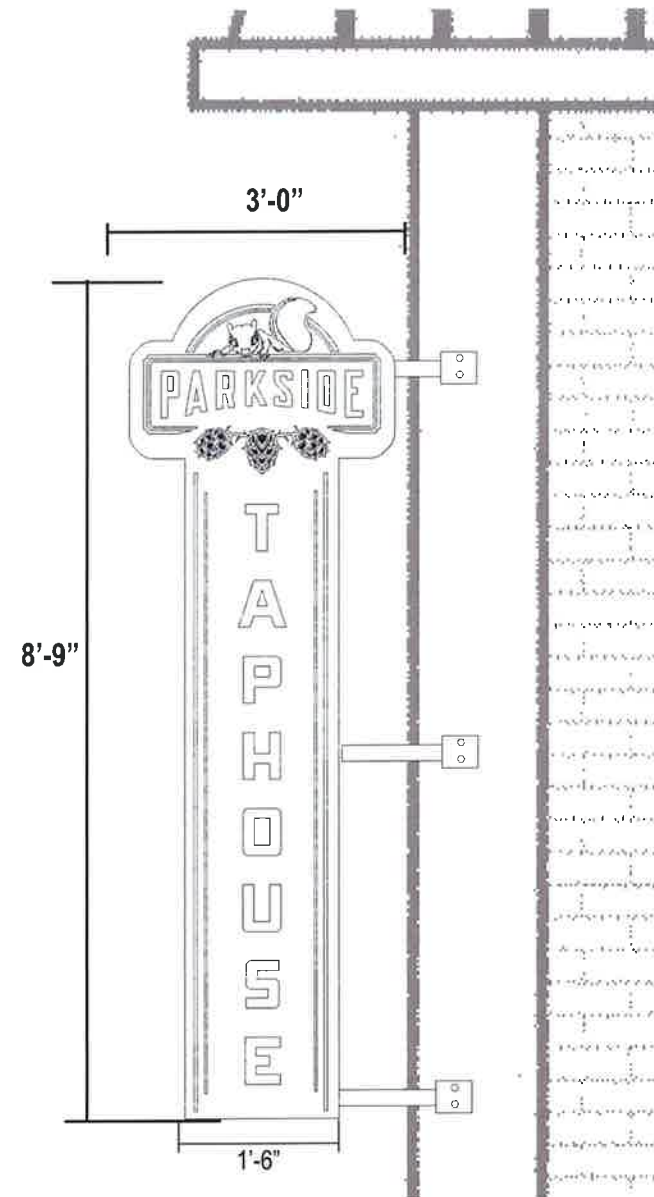
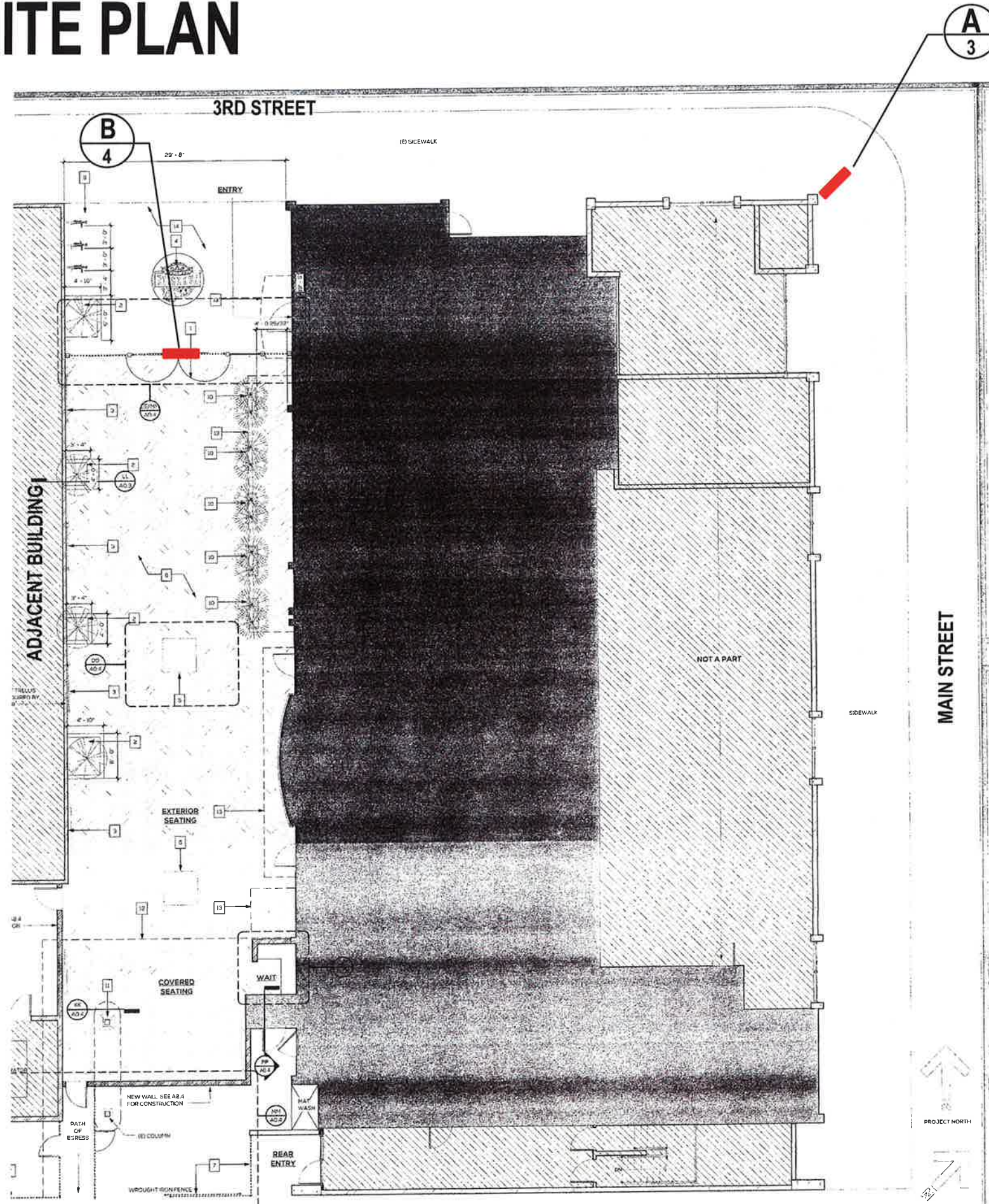

A D/F NON-ILLUMINATED PROJECTING CORNER SIGN - QTY: (1)
 SCALE: 1/2" = 1'-0"
 52.5 SQ. FT.
 (Includes both sides)



B SINGLE FACED - LED ILLUMINATED "GATE SIGN" - QTY: (1)
 SCALE: 1/2" = 1'-0"
 20.22 SQ. FT.

RECEIVED

MAY 25 2016

CITY OF CHICO
 PLANNING SERVICES

ATTACHMENT B

SHEET 2



signsofchico.com

158 Commercial Avenue
 Chico, California 95973
 Phone: (530) 343-2543
 Fax: (530) 343-7757
 Email: Signs@Chico.com
 Lic. No. 990728

PROJECT: Parkside Tap House 115 3rd Street, Chico, CA
 DRAWING: Sheet 2 - Site Plan DATE: 10/18/16
 DRAWN BY: LeAnn Cooley

(1) D/F NON-ILLUMINATED PROJECTING SIGN

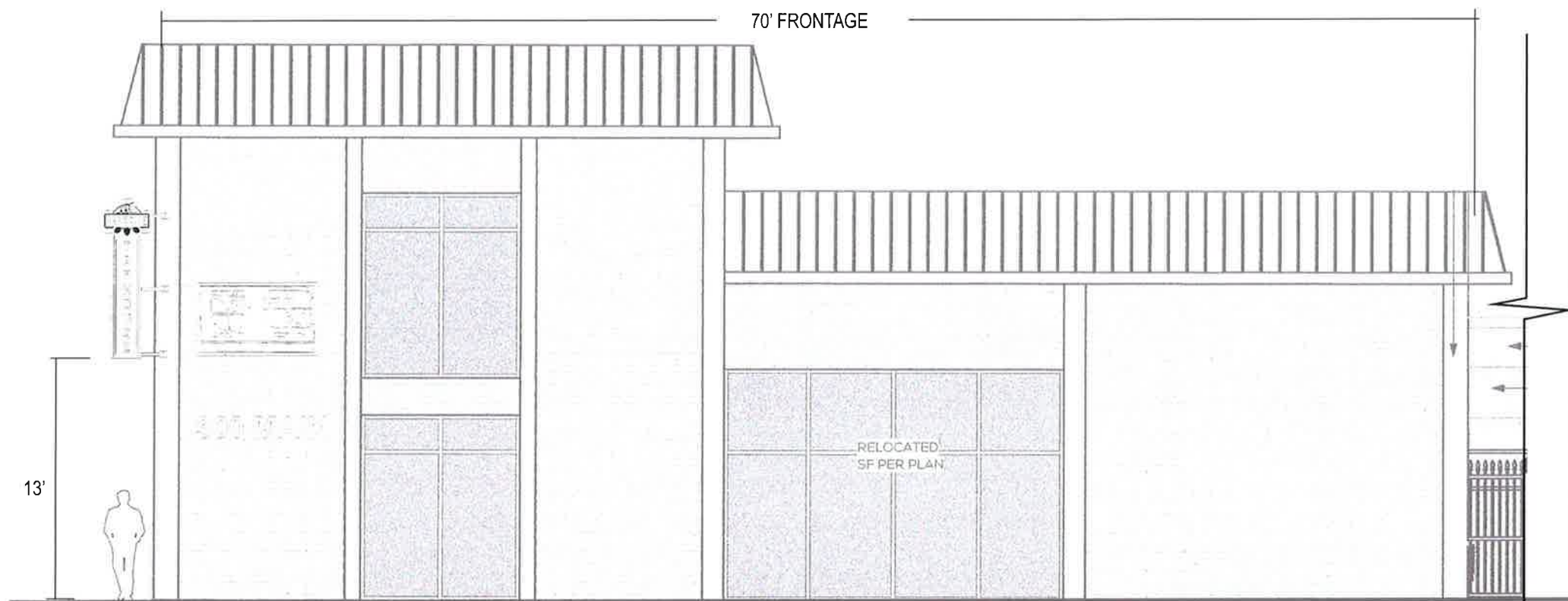

NORTH ELEVATION
SCALE: 1/8" = 1'-0"

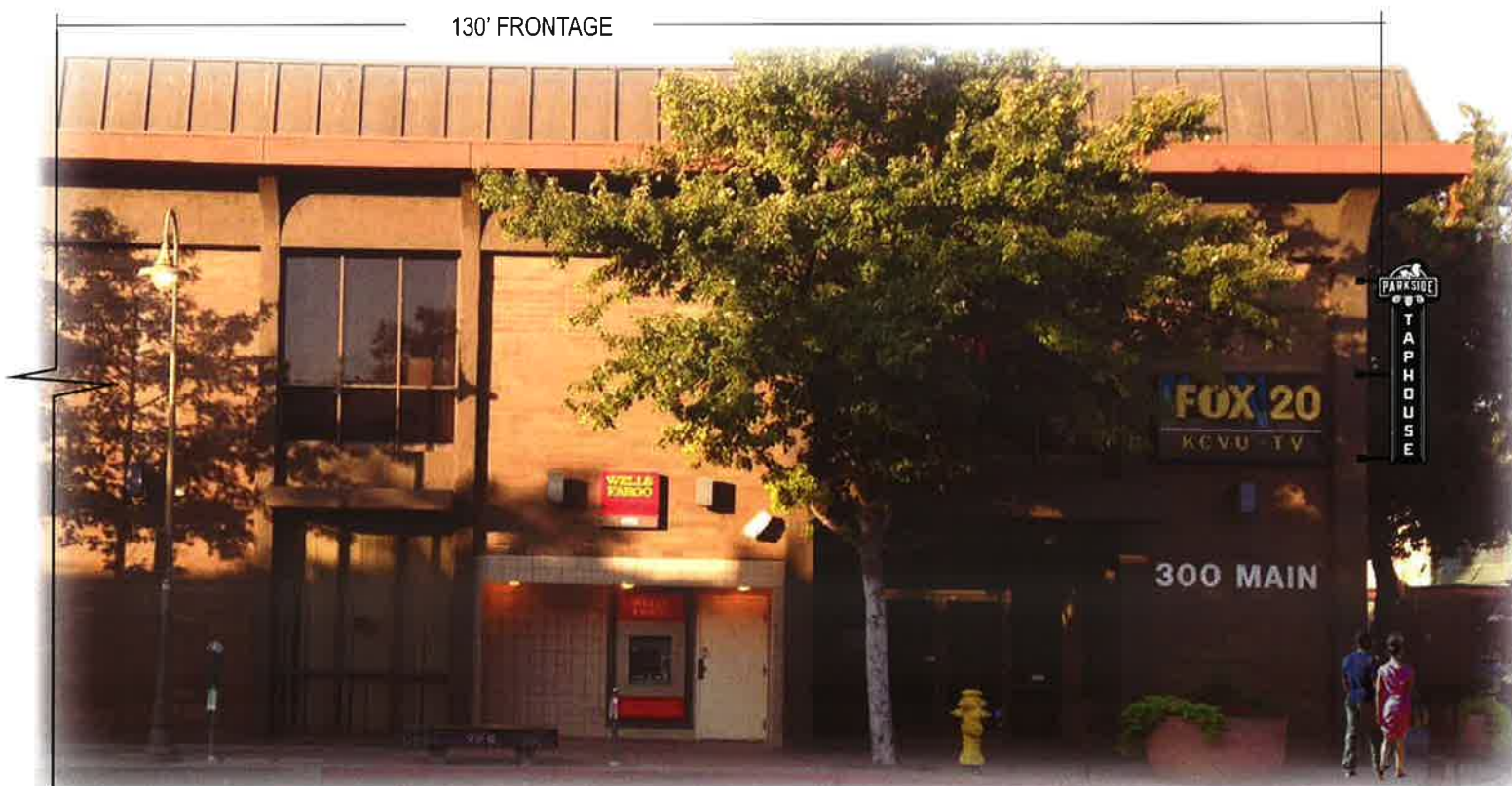

WEST ELEVATION
SCALE: 1/8" = 1'-0"

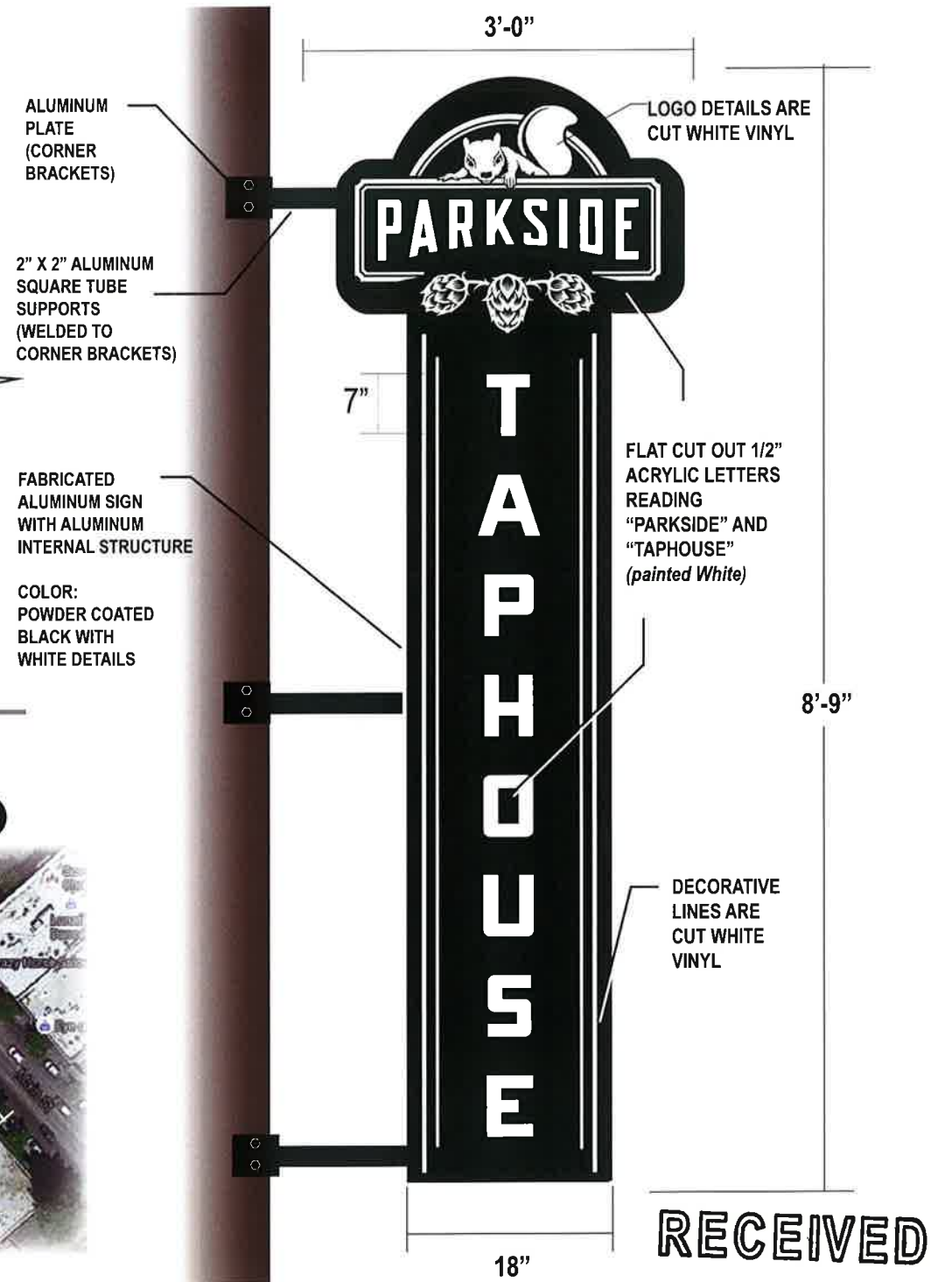
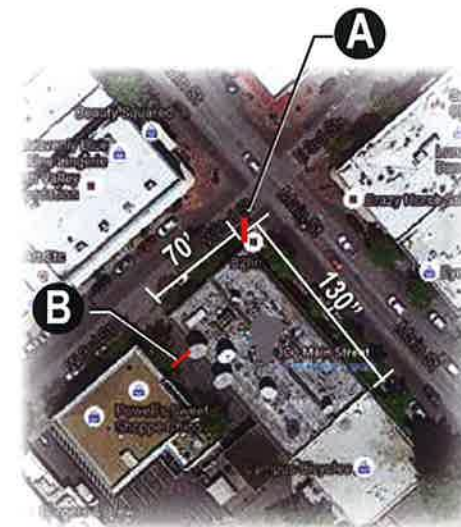

D/F PROJECTING CORNER SIGN - QTY: (1)
SCALE: 3/4" = 1'-0"
52.5 SQ. FT. CITY OF CHICO PLANNING SERVICES

OCT 25 2016
CITY OF CHICO PLANNING SERVICES



signsofchico.com

Chico, California 95973
Phone: (530) 343-2543
Fax: (530) 343-7767
Email: Signs@Chico.com
Lic. No. 990728

PROJECT: Parkside Taphouse 115 3rd Street. Chico, CA
DRAWING: Sign A - Sheet 3 DATE: 10/18/16
DRAWN BY: LeAnn Cooley

SHEET 3

ATTACHMENT C

(1) S/F LED ILLUMINATED GATE SIGN

SIGN FABRICATION BY RICHER'S EARTHEN IRON AND WOLFE ELECTRIC

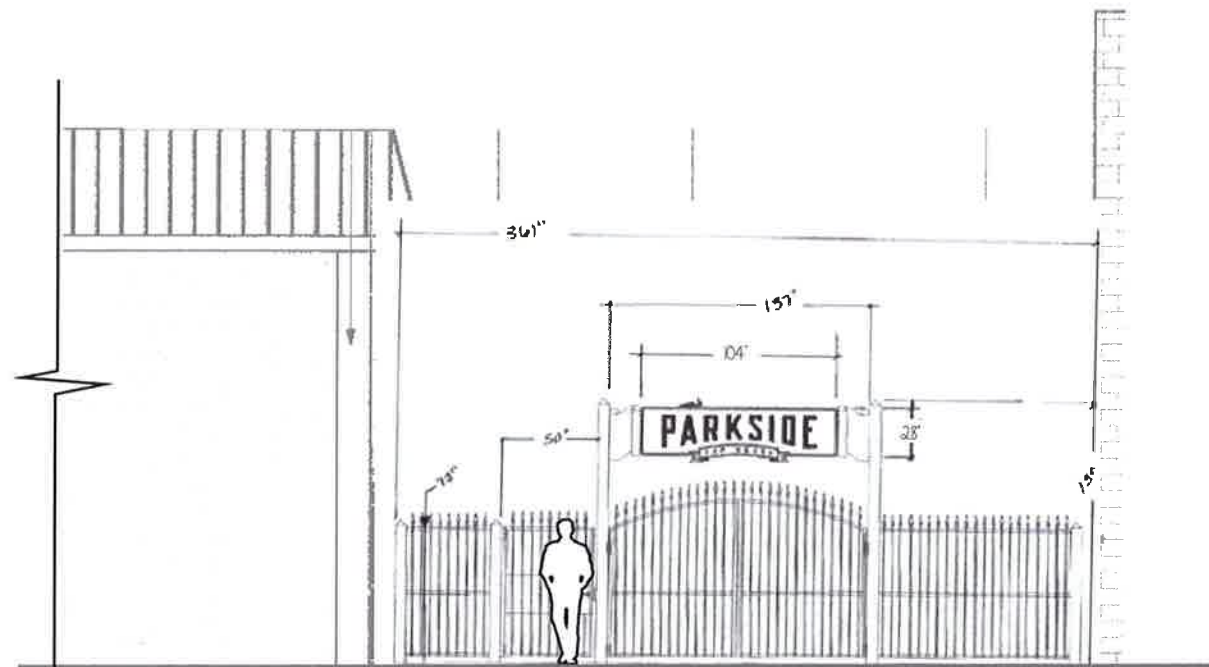

NORTH ELEVATION - PATIO
SCALE: 1/8" = 1'-0"

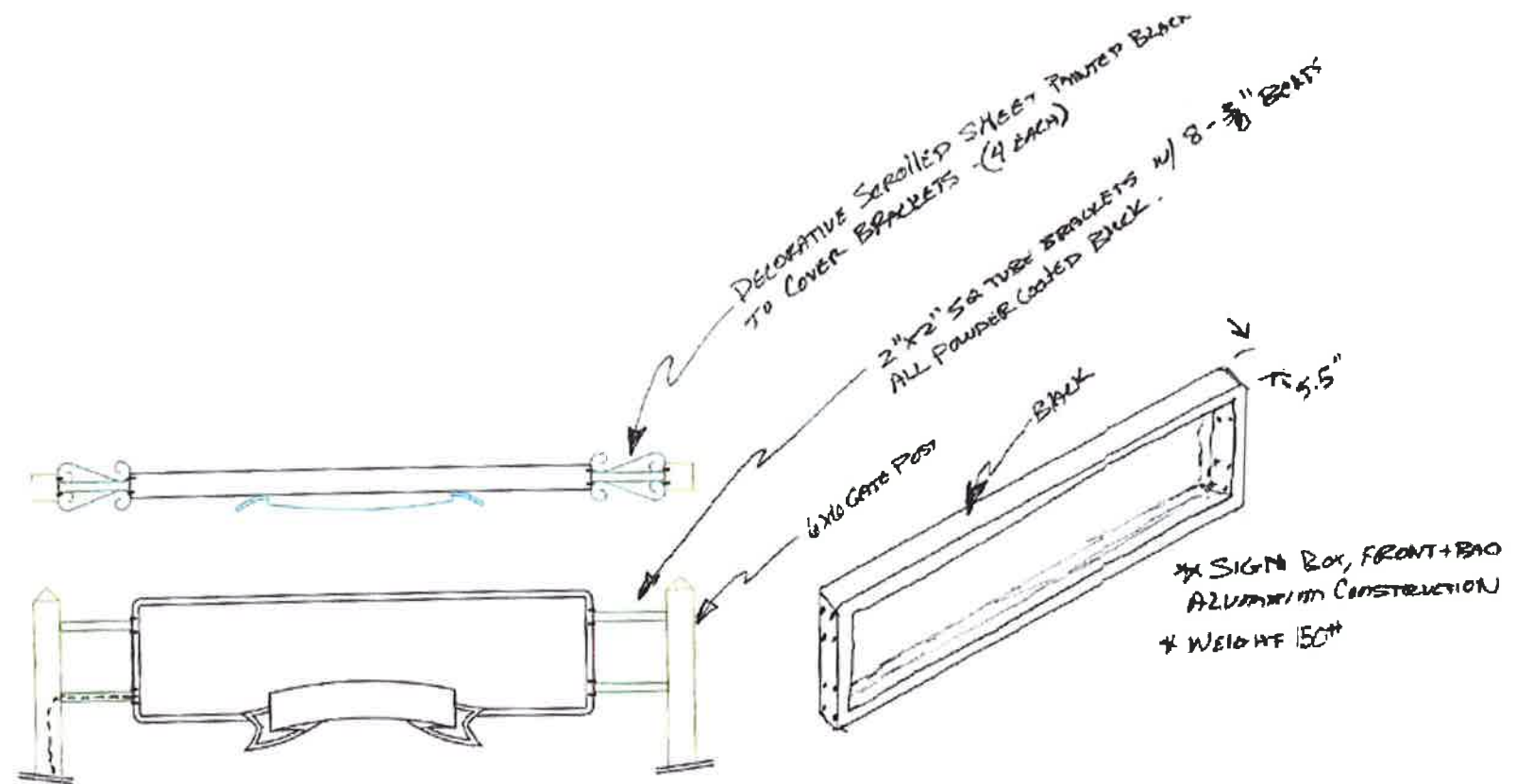

PARKSIDE TAP HOUSE GATE ENTRANCE SIGN

- * SIGN BODY - ALUMINUM CONSTRUCTION
- * FINISH - PAINTED
- * LETTERING - WHITE ACRYLIC INSIDE OPENINGS
- * ILLUMINATION - LED STRIP LIGHT (UL APPROVED) PLUG IN SYSTEM.
- * ELECTRICAL WIRING AND INSTALLATION TO BE PROVIDED BY ELECTRICAL CONTRACTORS.



GATE SIGN FABRICATION DETAILS
N.T.S.

B SINGLE FACED - LED ILLUMINATED "GATE SIGN" - QTY: (1)
SCALE: 1/2" = 1'-0" **20.22 SQ. FT.**

RECEIVED

MAY 25 2016

CITY OF CHICO
PLANNING SERVICES



Chico, California 95973
Phone: (530) 343-2543
Fax: (530) 343-7767
Email: SignsofChico.com
Lic. No. 990728

PROJECT: Parkside Tap House 115 3rd Street, Chico, CA
DRAWING: Sheet 4 - Sign B DATE: 10/18/16
DRAWN BY: LeAnn Cooley

SHEET 4

ATTACHMENT D

EXISTING AND PROPOSED SIGNAGE

3 EXISTING SIGNS

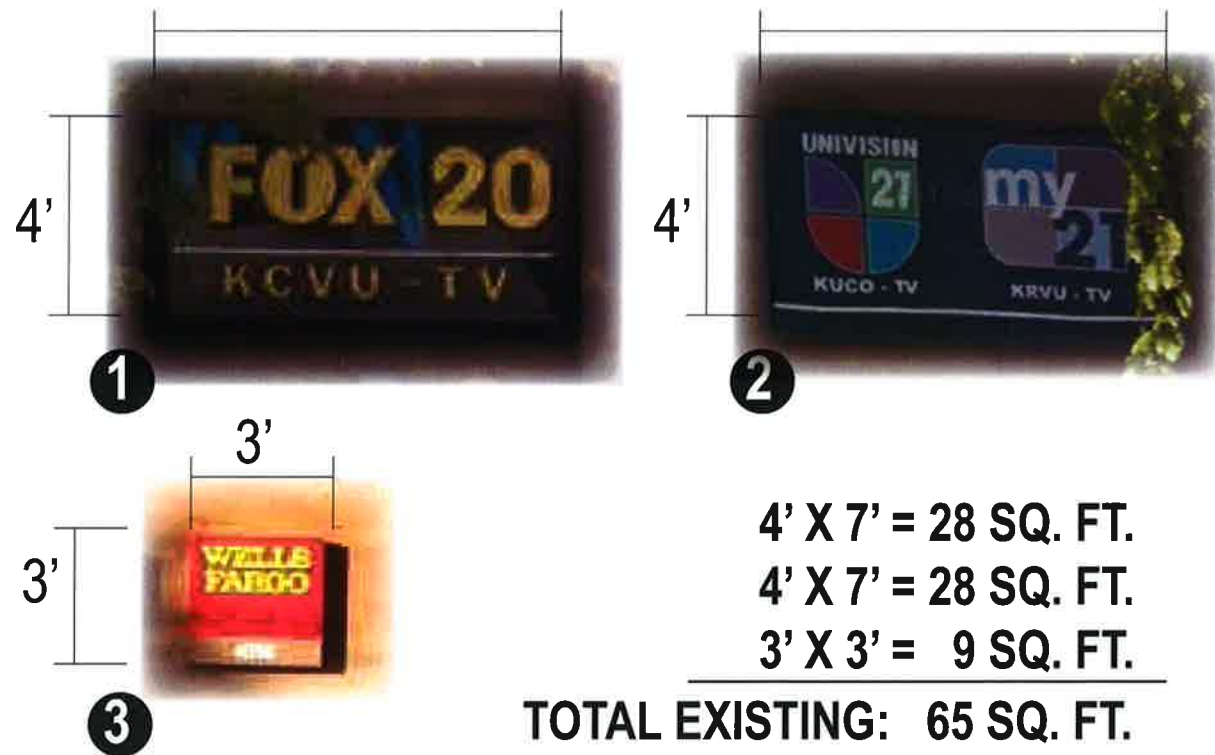

2 PROPOSED SIGNS

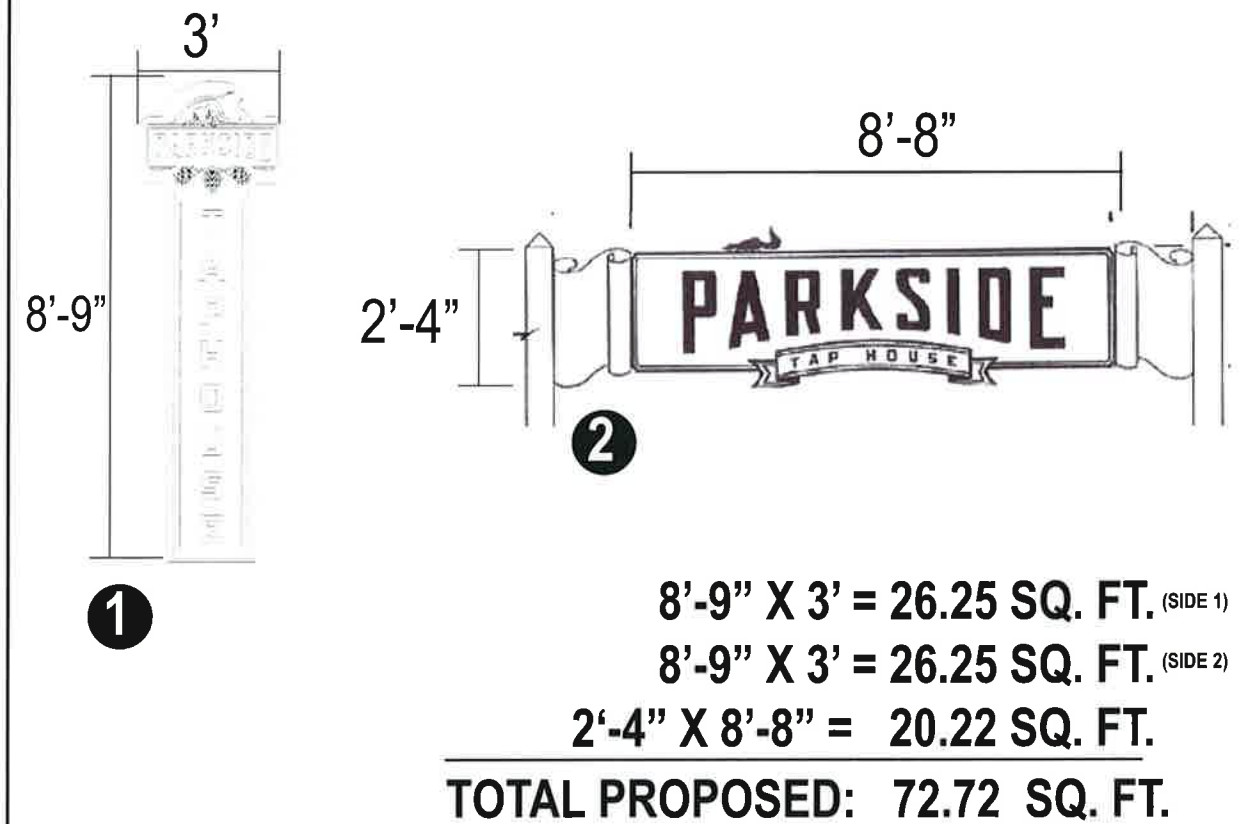

RECEIVED
 OCT 25 2016
 CITY OF CHICO
 PLANNING SERVICES



Exterior Signage Plan

115 3rd Street Chico, CA 95928

RECEIVED

OCT 25 2016

CITY OF CHICO
PLANNING SERVICES

Presented by:



signsofchico.com

158 Commercial Avenue
Chico, California 95973
Phone: (530) 343-2543
Fax: (530) 343-7767
Email: SignsOfChico.com
Lic. No. 990728

SHEET 1