



Architectural Review and
Historic Preservation Board
Agenda Report

Meeting Date 10/19/16

REPORT

DATE: October 12, 2016

File: PDP 16-04

TO: Architectural Review and Historic Preservation Board

FROM: Kelly Murphy, Assistant Planner, (879-6535, kelly.murphy@chicoca.gov)
Community Development Department

RE: Recommendation to the Planning Commission for the Urban Apartments Project –
Located at 1033 W. 5th Street & 1046 W. 6th Street (APN 004-202-007 and -018)

REPORT IN BRIEF

The applicant requests that the Board forward a recommendation of approval to the Planning Commission for the design of a 36-unit apartment complex as part of a proposed planned development permit (PDP). The PDP is necessary for the project to deviate from the requirement for 50-percent shading of all paved areas using landscaping. Staff believes the project meets the intent of the Code and supports the request to allow the required shading to be provided by the building in lieu of the required trees.

With a Board recommendation, the proposal must go to the Planning Commission for final consideration of the permit, including final architectural design approval.

RECOMMENDATION

Staff recommends that the Architectural Review and Historic Preservation Board adopt the required findings contained in the agenda report and recommend approval of the project, subject to conditions.

Proposed Motion:

I move that the Architectural Review and Historic Preservation Board adopt the required findings contained in the agenda report and recommend approval of the Urban Apartments Planned Development Permit (PDP 16-04), subject to the staff recommended conditions.

BACKGROUND

The applicant proposes to construct four 3-story apartment buildings, with a total of 36 units, along Walnut Street (State Route 32), between 5th and 6th Streets (see Location Map, **Attachment A**, and Project Description, **Attachment B**). The site is designated Commercial Mixed Use (CMU) on the General Plan Land Use Diagram and located within a CC-FS-COS (Community Commercial with Fraternity and Sorority and Corridor Opportunity Site overlay), zoning district. The residential density range typically allowed in the CMU district is 6 to 22 units per acre. With the –COS overlay, the range is increased to 15 to 70 dwelling units per acre. The project would result in a density of 38 units per acre.

One of the parcels (APN 004-202-007, 1046 W. 6th Street) is developed with a single-family residence planned for demolition. The other parcel, (APN 004-202-018, 1033 W. 5th Street), is undeveloped. A merger of these two parcels was approved by the Map Advisory Committee on August 11th, 2016, resulting in a single parcel 265 feet in length and 132 feet in width.

The majority of land uses adjacent to the 0.81-acre project site are residential dwellings, mostly multi-family. Specifically, north of the site are single-family houses primarily used as student rental properties. Commercial businesses and restaurants are located to the south. There are multiple apartment complexes on the east side. The site is bounded on its west by a commercial corridor (Walnut Street). The site is within walking and biking distance to California State University - Chico, and is near Class I and Class II bicycle facilities, Butte County Regional Transit (B-line), open space (Depot Park) and commercial services.

Vehicle access to the site would be provided via two main drive aisles off of 5th and 6th Streets (see Site Plan, **Attachment C**). Pedestrian access to the site would be available from all street frontages and entrances to the units would face the street. Internal site circulation is configured to allow for easy “way finding”, providing pedestrian walkways separate from vehicular drives.

The majority of the site would be secured by a wire-mesh fence with multiple gated entry points located around the property that would connect the internal pedestrian paths to the public sidewalk. Fencing along the rear yard (northern property line) would extend around the northwest and northeast corners of the site, terminating at the drive aisle entrances, and have a height of 5 feet. An 18” high-low wall with 5-foot wire-mesh fencing above is proposed for the front-yard (southern property line).

The main building entrance and lobby are located at the corner of 5th and Walnut, along an existing pedestrian and bicycle route. Covered (“tuck-under”) vehicle and bicycle parking would be provided on the ground floor level. The minimum parking requirement for the new units is 38 spaces. The project proposes a total of 47 vehicle parking spaces and 41 bicycle parking spaces (see Floor Plans, **Attachment D**).

The three-story structures would have a maximum height of 42 feet, 3 inches; however, the mass of the buildings would be differentiated by cantilevered volumes and varied roof planes and heights. In addition to the “tuck-under” parking provided on the ground level, there would be six (6) accessible units. A variety of textures and materials would be implemented into the building’s exterior design including smooth trowel plaster, corrugated metal siding, 20/30 stucco and metal mesh. The first floor would utilize light grey and dark grey smooth plaster. Stucco and metal siding would be used on the exterior walls of the second and third floors, alternating between dark and light grey color dominance (see Elevations, **Attachment E**). The proposed color scheme consists of white, grey, blue and clay colors (see Color Pallet, **Attachment F**). The roof plan incorporates decks and trellis structures. All HVAC units are located on the rooftop of the structure and screened from view.

The proposed orientation of the buildings on the site would create a multi-courtyard design. The main courtyard would include an outdoor recreation area to include a dipping pool, BBQ area, and landscaping (see Hardscape Plan, **Attachment G**). The landscape plan calls for a variety of species with moderate to low water demands including a mixture of trees, shrubs, and perennials (see Landscape Plan, **Attachment H**). Eighteen (18) Saratoga sweet bay and 2 marina strawberry trees would be planted along the northern property line, 14 fruitless olive trees along the Walnut Avenue street frontage (southern property line), and one 36-inch Oak tree on the corner of Walnut and West 6th Street. Landscaping would be provided between the new buildings along the pedestrian walkways to provide relief and add interest and color. Two (2) mid-sized Western redbud trees would be planted between Buildings D and C, and 2 between Buildings B and C. In addition to a decorative water feature, three (3) 36-inch London

plane trees would be planted at the main entrance/lobby. All existing vegetation onsite, including four large Valley Oak trees, is proposed for removal.

All exterior lighting would be low-intensity and energy efficient. Entrances, cantilevered façade volumes and roof eaves would be provided with recessed down lighting (see Exterior Ground Level Lighting Plan, **Attachment I**). Landscape lighting would be incorporated that accents the proposed plant material and building elements while staying visually subtle (see Landscape Lighting Plan, **Attachment J**). One monument sign reading “*The Urban*” is proposed outside the main entry/lobby, along the Walnut Street frontage (see Monument Sign, **Attachment K**). The sign would incorporate materials used in the building design, such as corrugated metal, and would have an area of 12 square feet (per side). Lighting details for the proposed sign are shown on **Attachments J and K**.

DISCUSSION

In cases where a project requires a discretionary approval by the Planning Commission or City Council in addition to design review, such as a Planned Development Permit in this case, CMC Section 19.18.024(B), requires the Board to forward a recommendation regarding the site and architectural design.

The proposed infill project would establish a residential use on an undeveloped site, consistent with the zoning and General Plan Designation, while reflecting the established residential, commercial and industrial character of the uses along Walnut Street. These aspects of the project are consistent with General Plan policies that encourage compatible infill development (LU-4.2 and LU-4.3), and context-sensitive design (CD-5.2 and CD-5.3). The design is also consistent with policies that call for a strong pedestrian orientation that promotes walking by connecting onsite pedestrian paths to the public sidewalk and by including architectural features that provide way-finding to the front doors (CD-3.2 and CIRC-4).

The project design is consistent with several Design Guidelines (DGs), including those that encourage a pedestrian-oriented design and relating the project to the immediate neighborhood (DGs 1.2.21, 1.2.31 and 1.4.11). The project is also consistent with DGs that call for residential buildings to increase safety/security by, incorporating entry porches, balconies and large windows that face the street (DG 4.1.11, 4.1.13, and 4.1.24). Additional Design Guideline discussion is provided by the architect in **Attachment B**.

A Planned Development Permit is necessary for the project to deviate from the requirement for 50-percent shading of all paved areas. While the parking area is mostly shaded using the “tuck-under” design, portions of the drive aisles are left exposed. Due to site area constraints, additional landscaping cannot be implemented to shade the paved drive aisles. Shade calculations and additional discussion regarding this PD request are provided in **Attachment L**, and detailed more specifically as follows:

Paved Area Shading Requirement:

As required by CMC Section 19.70.060E(2), trees shall be planted and maintained in planters or landscaped areas so that at tree maturity, 15 years, at least 50 percent of the total paving area, excluding only the entrance drives, shall be shaded at solar noon on June 21. The applicant is requesting that the shading requirement for paved areas be met using shade from the buildings rather than landscaping.

The total paved area (parking and drive aisles) is 14,915 square feet. Of that total, 3,120 square feet of the drive aisle is not directly covered by the buildings. As proposed, zero percent of the drive aisle would be shaded using landscaping. The unshaded drive aisle would equate to approximately 20-percent of the total paved area and would not significantly contribute to the “heat island” effect. Staff believes the project meets the intent of the Code and supports the request to allow the required shading to be provided by the building in lieu of the required trees.

RECOMMENDED DISCUSSION ITEMS

Staff recommends that the Board discuss the following items and condition the project as necessary:

Front-Yard Fence Height: As proposed, the front-yard fencing would exceed the maximum height allowance of 3-feet established by CMC Section 19.60.060 and cannot be approved.

Recommendation: Reduce the height of the fencing proposed in the front-yard (Walnut Street frontage) to comply with the 3-foot height maximum or remove from the project plans.

REQUIRED FINDINGS FOR APPROVAL

Environmental Review

The project has been determined to be categorically exempt pursuant to the California Environmental Quality Act (CEQA) Guidelines Section 15332 (In-Fill Development Projects). Consistent with this exemption, the project is: consistent with the applicable general plan designation, zoning regulations, and general plan policies; is less than five acres in size, substantially surrounded by urban uses; has no habitat value for special status species; will not result in any significant impacts regarding traffic, noise, air quality, or water quality; and can be adequately served by all required utilities and public services.

Architectural Review

According to the Chico Municipal Code Section 19.18.060, the Architectural Review and Historic Preservation Board shall determine whether or not a project adequately meets adopted City standards and design guidelines, based upon the following findings:

1. *The proposed development is consistent with the General Plan, any applicable specific plan, and any applicable neighborhood or area plans.*

At 38 dwelling units per acre the proposal falls within the allowable density range for the –COS overlay zone (15 to 70 units per acre). The project is consistent with several General Plan policies, including those that encourage compatible infill development (LU-1, LU-4, and CD-5). The project design is also consistent with policies that call for a strong pedestrian orientation that promotes walking by connecting internal pedestrian paths to the public sidewalk and by including architectural features that provide way-finding to the front doors (CD-3.2 and CIRC-4). The site is not located within the bounds of a Neighborhood Plan or area plan.

2. *The proposed development, including the character, scale, and quality of design are consistent with the purpose/intent of this chapter and any adopted design guidelines.*

The project design, materials and color palette are visually compatible with the

surrounding residential developments, while incorporating elements that encourage a pedestrian-oriented environment and help to establish a sense of place (DG 1.2.21, 1.2.31, 4.1.11, 4.1.13). The project provides variation in massing and roof plane heights, adding to aesthetic appeal (DG 4.1.15, 4.1.23) The project is also consistent with DGs that call for residential buildings to increase safety/security by, incorporating entry porches, balconies and large windows that face the street (DG 4.1.11, 4.1.13, and 4.1.24).

3. *The architectural design of structures, including all elevations, materials and colors are visually compatible with surrounding development. Design elements, including screening of equipment, exterior lighting, signs, and awnings, have been incorporated into the project to further ensure its compatibility with the character and uses of adjacent development.*

Vehicle parking is covered and interior to the site, thus not visible from the street. The proposed building materials are typical for residential developments and are compatible with the surrounding development which is a mixture of light-industrial, commercial and residential. Parking lot and exterior lighting is shielded and at pedestrian scale thereby not creating any unnecessary source of glare or contribute to the night sky pollution.

4. *The location and configuration of structures are compatible with their sites and with surrounding sites and structures, and do not unnecessarily block views from other structures or dominate their surroundings.*

The proposed structures are compatible with the site in that they provide functional, adequate setbacks, with the off street parking and recreation area located on the project interior. Although the structures would be three stories, they would not unnecessarily block views or dominate their surroundings as the overall building height would be less than 45 foot maximum allowed in the CC zoning district, and well below the maximum height permitted within the –COS overlay (65 feet).

5. *The general landscape design, including the color, location, size, texture, type, and coverage of plant materials, and provisions for irrigation and maintenance, and protection of landscape elements, have been considered to ensure visual relief, to complement structures, and to provide an attractive environment.*

The proposed landscape plan includes a variety of trees and shrubs that would serve useful functions and have a range of colors and textures that would provide visual interest throughout the year. The trees proposed along the Walnut Street frontage would provide visual relief for the buildings, and the interior plantings would contribute to an attractive living environment. Trees proposed along northern property line would enhance privacy between the adjacent properties.

RECOMMENDED CONDITIONS OF APPROVAL

1. The front page of all building plans shall clearly note that the project shall comply with the Urban Apartments Planned Development Permit (PDP 16-04).
2. The approval documents for this project consist of the following exhibits:

- a. Planned Development Permit Site Plan (sheet A-0.10)
 - b. Landscape Plan (sheets L-1.0 through L-2.2)
 - c. Color Elevations and Floor Plans (sheets A-1.10 through A-2.40),
 - d. Color Sample Sheet, and
 - e. Lighting Plans (sheets A-5.10, E-0.01 and L-4.0)
 - f. Monument Sign (sheet A-6.30)
3. Planned Development Permit 16-04 authorizes the following development standards for the Urban Apartments development:
 - a. Relief from compliance with shading requirement for paved areas using trees and landscaping.
 4. The applicant shall submit a tree removal permit application pursuant to CMC Section 16.66.070 prior to the issuance of building permits.
 5. The 5-foot wire-mesh fencing proposed in the front-yard (Walnut Street frontage) of the project site shall be reduced to comply with the 3-foot height maximum or be removed from the project plans.

PUBLIC CONTACT

Public notice requirements were fulfilled by placing a notice on the project site and by posting of the agenda at least 10 days prior to this ARHPB meeting.

DISTRIBUTION

Internal (3)

Mark Wolfe, Community Development Director
Kelly Murphy, Assistant Planner
File: PDP 16-04

External (4)

Andrew Clark, President of SCSH Chico LLC, 1023 ½ Abbot Kinney Blvd., Venice CA 90291
Vladimir Tomalevski, 2332 Cotner Avenue, Suite 303, Los Angeles CA 90064
Gaudet Design Group, 2109 Stoner Avenue, Los Angeles, CA 90025
NorthStar Engineering, 111 Mission Ranch Blvd., Suite 100, Chico CA 95926

ATTACHMENTS

- A. Location Map
- B. Project Description
- C. Site Plan
- D. Floor Plans
- E. Elevations
- F. Color Pallet
- G. Hardscape Plan
- H. Landscape Plan
- I. Ground Level Exterior Lighting Plan
- J. Landscape Lighting Plan
- K. Monument Sign
- L. Planned Development Request

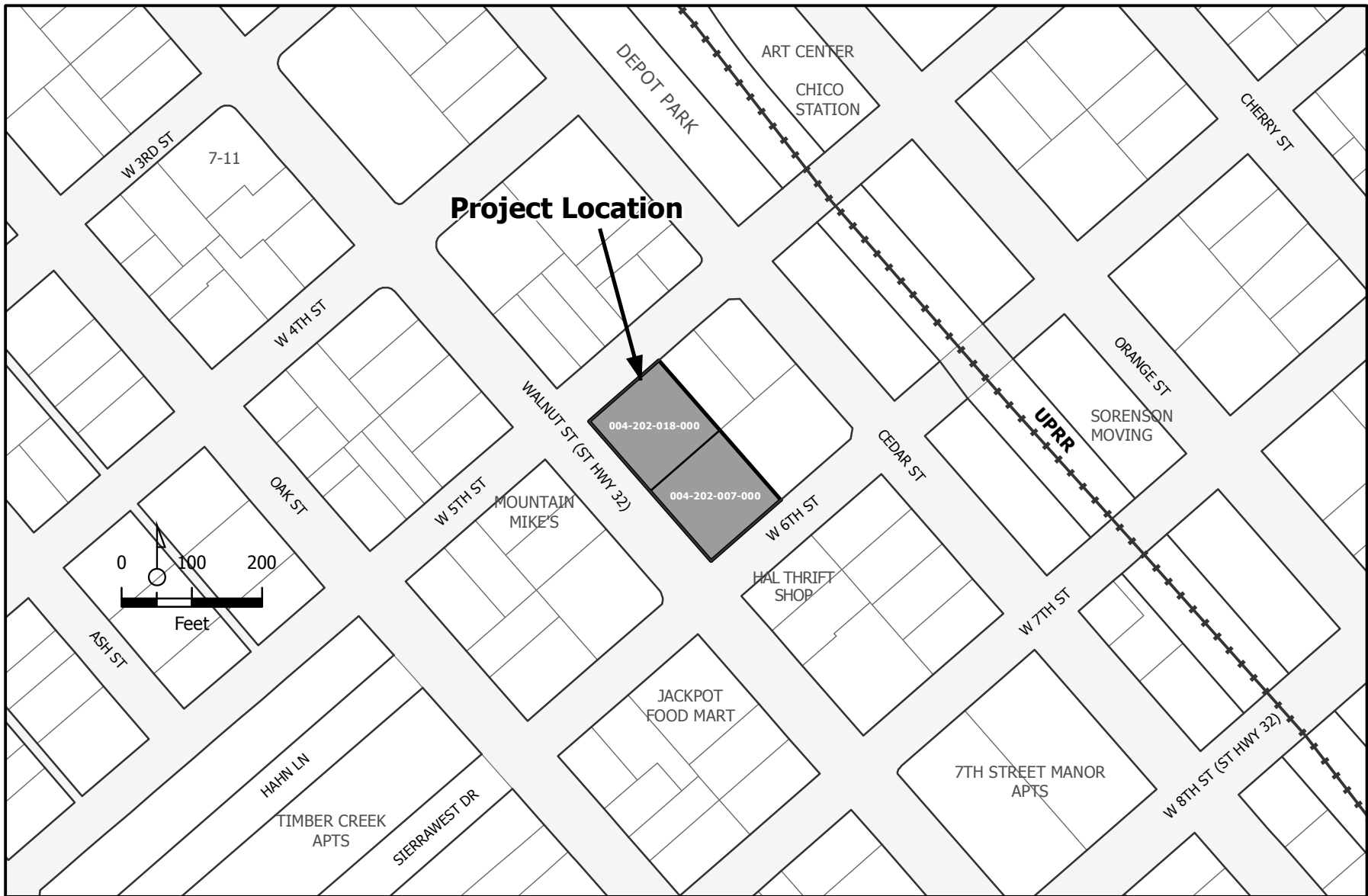

PDP 16-04 (The Urban Apartments)
 1033 W 5th Street and 1046 W 6th Street
 APN 004-202-007-000, 004-202-008-000



RECEIVED

2016-08.22

AUG 23 2016

PROJECT DESCRIPTION

**CITY OF CHICO
PLANNING SERVICES**

The proposed project site is a peninsula type lot with 3 sides of street exposure, with the main exposure facing Walnut Avenue. The project consists of a new 3-story, 36 unit, apartment complex that encompasses 4 separate buildings. The buildings' orientation on the site creates a multi-courtyard scheme. At the heart of the main courtyard is an outdoor recreation area that includes a dipping pool, BBQ, area, adjacent indoor recreation room, and lush landscaping. The secondary courtyards incorporate walking paths and lush landscaping. The parking for the project is accessed from the central courtyard by way of two main drive aisles that are accessed from 5th street and 6th street. The vehicle parking is screened from the public way by bicycle parking corals, embracing the cities pedestrian oriented feel. Entrances to the units and the units' living rooms face the street activating the community connection. The main building entrance and lobby are located at the corner of 5th Street and Walnut Avenue connecting to an existing pedestrian and biking route. The exterior entry is celebrated and defined by a dynamic water feature, roof covering and lush landscaping. The building's exterior incorporates a variety of textures and materials including smooth trowel plaster, corrugated metal siding, 20/30 stucco and metal mesh. The mass of the buildings is differentiated by cantilevered volumes, varied roof planes and height, and expression of exterior materiality and color.

DESIGN OBJECTIVES

The following is a list of applicable design objectives from the city's Design Guideline Manual and the applicable design solutions proposed to meet the objective.

1

COMMUNITY DESIGN

1.1 Site Design:

1.1.1 COMMUNITY IDENTITY

Design Objective:

Reinforce the positive qualities of a site's surrounding built or natural environment

Design Solutions:

(DG1.1.13) The project reinforces a pedestrian friendly environment by emphasizing bicycle use, and a pedestrian active frontage. Bicycle parking is placed in front of vehicular parking effectively screening out the vehicle and emphasizing the bicycle orientation of the city. Entrances to the units are located at grade and front along the prominent street elevation of the project. Internal exterior walking paths are visible from the public way further emphasizing the pedestrian orientation of the project.

(DG1.1.14) The project minimizes views of automobiles from the public right of way by locating the parking areas and drive aisles to the sides and rear of the site. Parking areas located along the front of the property are screened by bicycle parking and unit entrances

(DG1.1.15) The project's buildings are located close to the streets emphasizing the pedestrian orientation of the project and allowing for internal courtyards that allow for vehicle drive aisles to be screened from public view

1.1.3 PUBLIC SPACES AND PEDESTRIAN AMENITIES

Design Objective:

Aesthetically integrate areas for safe public gathering, shelter, or rest in site design

Design Solutions:

(DG1.1.32) The project provides for a variety of pedestrian gathering areas including a pool/recreation area located within the main central courtyard, walking paths around the entire site surrounded by lush landscaping and embedded sitting areas, resting places defined by unique benches that embrace the proposed landscaping and take advantage of on the shade of proposed trees and private roof decks that take advantage of surrounding vistas

(DG1.1.33) Pedestrian gathering spaces are defined by special textures, water features, landscaping, architectural features, sitting areas and accent lighting

1.1.4 PARKS AND OPEN SPACE

Design Objective:

Architecturally integrate and reinforce the sense of place of the surrounding neighborhood, environment, or greater Chico community regarding site design of passive and active open space areas.

Design Solutions:

(DG1.1.32) The project provides for a variety of pedestrian gathering areas including a pool/recreation area located within the main central courtyard, walking paths around the entire site surrounded by lush landscaping and embedded sitting areas, resting places defined by unique benches that embrace the proposed landscaping and take advantage of on the shade of proposed trees.

(DG1.1.33) Pedestrian gathering spaces are defined by special textures in the form of architecturally scored and colored concrete, Infinity edge water feature, lush landscaping, various sitting areas and custom landscape lighting.

1.2 Architecture:

1.2.1 MASSING, SCALE, AND FORM

Design Objective:

Design with elements that enhance a pedestrian-level scale regarding the massing, scale and form of buildings

Design Solutions:

(DG1.2.11) The proposed project utilizes massing, scale, and form that transitions the existing pattern of development to the proposed. The surrounding buildings consist of 1, 2 and 3 story buildings of varied scale and form. The proposed project consists of 2 and 3 story volumes that undulate along the buildings' façades. The ground level story is activated by large storefront glazing, pedestrian walkways, bicycle parking corals, and unit entrances emphasizing the pedestrian scale seen throughout the city.

(DG1.2.12) The project responds to the main linkage of 5th street as a connecting element to the University by locating the primary building entry along 5th Ave. The corner is activated by a pedestrian plaza containing a water feature, shade tree sitting area and storefront glazing that connects the recreation room and lobby to the street.

(DG1.2.13) The scale and character of the proposed development blends well with the varied scale of buildings in the surrounding context by creating a

varied roof line and undulating front facade that is broken up by courtyards allowing green spaces to bleed out toward the public way.

1.2.2 DESIGN CONCEPT, STYLE, AND DETAILS – FACADES and ROOFS

Design Objective:

Reinforce the sense of place for a given development through the design of building facades and roofs

Design Solutions:

(DG1.2.21) The design of the buildings' facades relates to the immediate neighborhood by utilizing materials and forms that are seen on the surrounding light industrial and commercial buildings.

(DG1.2.22) The proposed project's rooflines and building faces are varied in height and depth adding to the character of the development and the surrounding context.

1.2.3 DESIGN CONCEPT, STYLE, AND DETAILS – BUILDING MATERIALS AND COLORS

Design Objective:

Add visual interest with building materials and color that reinforces the overall architectural design concept and sense of place

Design Solutions:

(DG1.2.31) The color palette for the proposed project consists of natural colors that blend into surrounding context while still creating a vibrant feel.

(DG1.2.32) The proposed building materials relate contextually to the existing pattern of development creating a connection to the sense of permanence and history of the area.

1.3 N/A

1.4 Art in Public Spaces

1.4.1 ART IN PUBLIC SPACES

Design Objective:

Consider art components in private development as integral features of a project's site and/or building design

Design Solutions:

(DG1.4.11) Elements such as the architectural/sculptural benches located under proposed shade trees along the public way, the sculptural water feature at the prominent corner/entry, and artistic landscape features all combine to reinforce the sense of place and the natural character of the Chico community.

(DG1.4.13) Functional design features such as the sculptural benches serve as a place to gather, rest, or simply read a book in the shade of a tree while at the same time creating a visually stimulating element when not in use.

1.5 Art in Public Spaces

1.5.1 EXTERIOR LIGHTING

Design Objective:

Design architecturally integrated, energy efficient, and shielded or recessed exterior lighting so that direct glare and reflections are minimized and confined within the boundaries of the site.

Design Solutions:

(DG1.5.11) Entrances, cantilevered façade volumes, and roof eaves are provided with recessed down lighting that enhances the project's character while providing for security, safety and ease of access.

(DG1.5.12) Landscape lighting is provided that accents the proposed plant material and building elements while staying visually subtle.

(DG1.5.14) The intensity of the proposed exterior light fixtures is minimal and directed downward by way of recessed lighting and sconce down lights to minimize glare and energy consumption while maintaining safety, security and the character of the project at night.

(DG1.5.16) The proposed exterior lighting is designed such that the lights are at the pedestrian level along walkways, primarily located in the underside of second story cantilevered building volumes. The lights are directed downward and reserved for the pedestrian level which avoids glare.

1.6 Signage

1.6.1 EXTERIOR LIGHTING

Design Objective:

Architecturally integrate project signage with a given development project so as to not dominate the site or building design

Design Solutions:

(DG1.6.11) The proposed signage will enhance the projects identity by utilizing the buildings' materials and forms. The proposed monument sign follows the existing pattern of signage in the neighborhood by locating the sign along Walnut Ave (the primary building elevation and busiest street). The surrounding buildings all have monument signs located along walnut.

(DG1.6.12) Only one sign is proposed and therefore will be consistent within the development

(DG1.6.13) Signage lighting will be directed at the sign directly and not onto neighboring properties

(DG1.6.14) The proposed signage is modest in size and will not dominate the building façade

(DG1.6.16) The proposed signage is a Pedestrian-scaled monument sign located on a base.

1.7 Energy Conservation

1.7.1 EXTERIOR LIGHTING

Design Objective:

Consider passive design, and active energy conservation systems early in the design phase of project development

Design Solutions:

(DG1.7.11) Solar orientation was considered when placing buildings. Building facades have a primary east west orientation allowing for effective shading device to be used on south facing facades.

(DG1.7.12) Energy efficient LED light fixtures are proposed for the buildings' exterior.

(DG1.7.14) Roof eave shading elements are proposed for the large window openings along the south side of the project.

(DG1.7.15) Unshaded pavement is minimized along south and west elevations

4.1 Site Design:

4.1.1 BUILDING PLACEMENT AND ORIENTATION – STREETScape AND PUBLIC REALM

Design Objective:

Innovative and diverse design of residential streetscapes that facilitate interaction between residents and include homes that are positively oriented to the street

Design Solutions:

(DG4.1.11) The proposed project orients unit and building entrances toward the street and sidewalk, along with the primary living room windows, to create a sense of community.

(DG4.1.12) The proposed project is oriented to the street and to pedestrians. Parking is removed from the primary entrances and contained within the core of the property allowing for pedestrian oriented circulation, and exposure.

(DG4.1.14) The proposed building facades incorporate a variety of unit types, mass, scale, fenestration, and material, creating a varied street scape.

(DG4.1.15) The proposed project utilizes varied mass, building size, materials and roof heights to create a dynamic streetscape

4.1.2 BUILDING PLACEMENT AND ORIENTATION – ORIENTATION OF HOMES ON LOTS

Design Objective:

Site Design of residential projects that create safe, pleasant, and active neighborhoods

Design Solutions:

(DG4.1.23) The proposed project has varied building mass, height, façade depth, texture, and materiality which creates a dynamic and pleasant appearance

(DG4.1.24) Front entry porches, large living room floor to ceiling glazing, and balconies face the public way creating a sense of community and provides “eyes on the street” for safety and security

4.1.3 INTERNAL CIRCULATION

Design Objective:

Circulation patterns that provide for the safe and efficient movement of vehicles, pedestrians, and bicyclists

Design Solutions:

(DG4.1.31) Internal site circulation is configured to allow for easy “way finding”. Pedestrian paths are clearly separate from vehicular drives. Building entrances are clearly located along pedestrian pathways. Pedestrian signage will be located along pathways to direct visitors to a particular unit

(DG4.1.32) The vehicular site circulation consists of a Shared driveway that is accessed from the two secondary streets that the project site fronts on. This limits the amount of curb cuts and reduces the amount of impervious surfaces

(DG4.1.33) Vehicular drives are separated from pedestrian paths by an elevation change, landscaping, paving differentiation and buildings, thus clearly delineating the pedestrian areas as separate from vehicular areas while maintaining a visually interesting aesthetic

(DG4.1.35) The majority of the site is secured by a gated fence with multiple entry points located around the property connecting the internal pathways to

the public sidewalks. The gated access points are remotely controlled by residents. Many unit entrances face the street

4.1.4 PUBLIC SPACE/PEDESTRIAN AMENITIES

Design Objective:

Site Design of residential projects that create aesthetically pleasing and vibrant places to gather and provide common amenities for use and enjoyment of residents

Design Solutions:

(DG4.1.41) Convenient pedestrian pathways connect all units to the common courtyard spaces around the property

(DG4.1.42) Common open space areas are distributed throughout the project and serve as an integral component of the design concept

(DG4.1.44) Open space areas consist of both common recreation areas and private balconies and roof decks

(DG4.1.44) Lighting of open space areas is created by way of recessed downlights and subtle landscape lighting, limiting the glare impacts to residents and neighboring properties

(DG4.1.45) Resident amenities include: Picnic tables, a barbeque area (with adjacent shade structure), a dipping pool, an indoor recreation room, and natural open space areas where residents can simply enjoy the shade of a tree

(DG4.1.47) Sculptural benches that surround landscape areas are located at the 2 prominent corners of the site. The common recreation room fronts the street and utilizes large storefront glazing to animate the project from the perspective of the public. A publicly viewed water feature accents the main entry to the site.

4.1.5 PARKING

Design Objective:

Parking areas that do not dominate views from public streets and sidewalks

Design Solutions:

(DG4.1.51) A common shared driveway serves as a sort of "alley down the middle of the site and is screened from public view by buildings and bicycle parking.

(DG4.1.52) Pedestrian pathways connect parking areas to the residential units in a direct and convenient manner

(DG4.1.53) Based on the parking configuration parking lot lighting is located within the tuck under parking. Exterior lighting is kept to a minimum to serve the drive aisle thus limiting glare impacts to residents

4.1.6 GARAGE PLACEMENT AND DESIGN

Design Objective:

To ensure that the garage is visually subordinate to the residential unit through design and placement

Design Solutions:

(DG4.1.61) To minimize the visual impact of garages they have been placed so that they are recessed from the front facade of the building and screened by bicycle parking corals and unit entrances. The second story of the residential

building cantilevers over the garage. Tandem parking is utilized to reduce the appearance of the garage from the street.

4.2 Architecture:

4.2.1 MASSING SCALE AND FORM

Design Objective:

Visual interest in the streetscape via attention to the pedestrian-level scale and compatibility with surrounding properties

Design Solutions:

(DG4.2.11) The mass of the proposed project is broken up into smaller components and articulated in such manner that the overall perceived mass of the building is reduced. Fenestration defines the individual unit while breaking up the façade to eliminate a monotonous façade. Roof overhangs and wall projections breakdown the scale of the building mass. Materiality and texture changes further breakdown the perceived mass of the buildings.

(DG4.2.12) The scale of the project is transitioned to the surrounding community scale by varying the project buildings between 2 and 3 stories

(DG4.2.13) Individual Units are defined by building masses and materiality

4.2.2 MASSING SCALE AND FORM

Design Objective:

Incorporating design elements that establish a clearly identifiable architectural style

Design Solutions:

(DG4.2.21) Varied exterior expression and unit orientation breaks up the visual monotony of a repetitious building configuration.

(DG4.2.22) The architectural expression, while varied, is harmonious and creates a unified project identity.

4.2.3 STYLE AND DESIGN DETAILS - Elevations

Design Objective:

Design Details of residential building elevation that reinforce a clear architectural style

Design Solutions:

(DG4.2.31) The visual interest of the front elevations are enhanced by the following: Façade colors and accent materials enhance the street scape while harmoniously connecting to the surrounding community. The proposed building façades are articulated with rich architectural detailing including roof overhangs, window detail treatments, reglet patterns, and material/color that all combine to create a rich architectural character

(DG4.2.32) Architectural features are provide at he front entrances to units that define the entry, provide a functional seating area and are connected to the public way and parking areas by way of clearly defined pedestrian paths.

4.2.4 STYLE AND DESIGN DETAILS - Entries

Design Objective:

Residential entries that create an inviting transition between public and private areas while supplying necessary shelter and security

Design Solutions:

(DG4.2.41) Unit entries are clearly defined by covered patios/walkways and entry benches

(DG4.2.42) Entry doors are accented by vibrant colors that relate to the project composition

(DG4.4.43) Building entries are protected from the elements by second story cantilevers

(DG4.2.44) Security is provided to the unit entries by creating a visual connection to the street and by providing adequate lighting that reduces glare
Impacts to surrounding properties

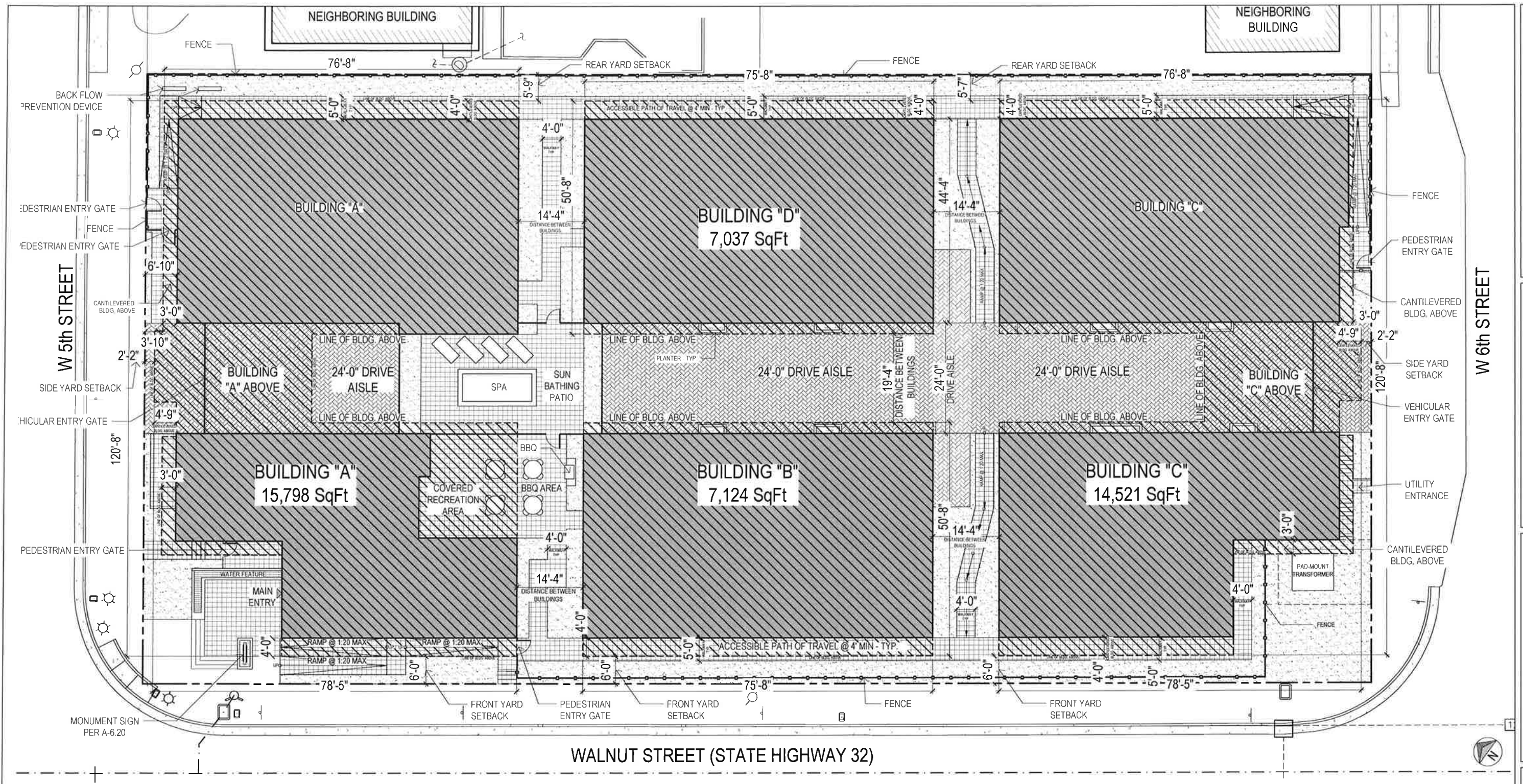

NOTE 1: BUILDINGS SHALL HAVE APPROVED ADDRESS NUMBERS, BUILDING NUMBERS OR APPROVED BUILDING IDENTIFICATION PLACED IN A POSITION THAT IS PLAINLY LEGIBLE AND VISIBLE FROM THE STREET OR ROAD FRONTING THE PROPERTY. (R319)

NOTES
NO SCALE 3

- | | | | | | |
|-------|--------------------------|------|----------------------------------|-----------|--------------------------------------|
| --- | BUILDING LINE ABOVE | GM | GAS METER | [Pattern] | LANDSCAPE AREA |
| - - - | SUBSURFACE DRAINAGE LINE | EM | ELECTRICAL METER | [Pattern] | WATER |
| - - - | PROPERTY LINE | WM | WATER METER | [Pattern] | ASPHALT DRIVEWAY |
| --- | FENCE | RICS | REMOTE IRRIGATION CONTROL SYSTEM | [Pattern] | ARCHITECTURAL CONCRETE WALKWAY |
| DS | DOWNSPOUT | OD | OVERFLOW DRAIN | [Pattern] | NEW GROUND FLOOR BUILDING |
| HB | HOSE BIB | AD | AREA DRAIN | [Pattern] | NEW 2nd AND 3rd STORY BUILDING ABOVE |
| NGS | NATURAL GAS STUBOUT | FD | FRENCH DRAIN | | |

SITE PLAN
3/32" = 1'-0" 2

LEGEND
NO SCALE 1

L+V architects
2332 CORNER AVE, SUITE 303
WEST LOS ANGELES, CA
90024
T: 310.914.6577
WWW.LVARCH.COM

THE URBAN - NEW APARTMENT COMPLEX
1033 W. 5th Street + 1046 W. 6th Street
Chico, CA 95926

TITLE: SITE PLAN
NOT FOR CONSTRUCTION

September 22, 2016

A-0.10

L+V architects
2332 COTNER AVE, SUITE 303
WEST LOS ANGELES, CA
90064 914.8577
WWW.LVARCH.COM

THE URBAN - NEW APARTMENT COMPLEX
1033 W. 5th Street + 1046 W. 6th Street
Chico, CA 95926

NOT FOR CONSTRUCTION

TITLE: FIRST FLOOR PLAN

September 22, 2016

A-1.10

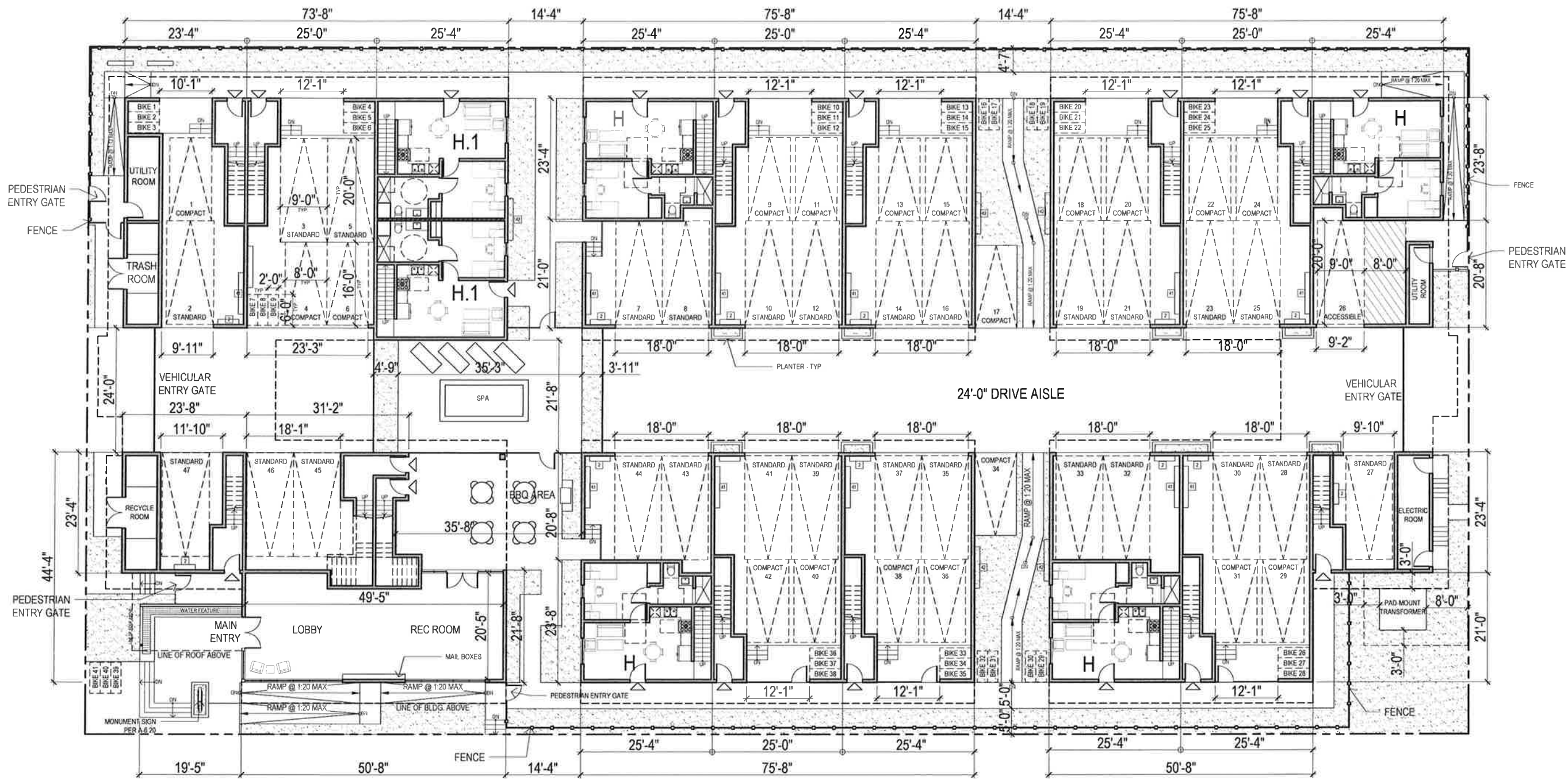

FIRST FLOOR PLAN
3/32" = 1'-0" 2

- 1 GAS FURNACE
- 2 TANKLESS WATER HEATER
- 3 KITCHEN SINK
- 4 DISHWASHER
- 5 RANGE
- 6 COOK TOP
- 7 WALL OVEN
- 8 REFRIGERATOR FREEZER COMBO
- 9 REFRIGERATOR
- 10 FREEZER
- 11 KITCHEN HOOD
- 12 PANTRY w/ ADJUSTABLE SHELVES
- 13 24" BASE CABINETS w/ 4" TOE SPACE
- 14 14" UPPER CABINETS
- 15 42" HIGH BAR
- 16 LAVATORY
- 17 BUILT-IN MILLWORK
- 18 22" BATHROOM BASE CABINET w/ 4" TOE SPACE
- 19 SHOWER
- 20 SHOWER BENCH
- 21 LOW CONSUMPTION WATER CLOSET
- 22 MIRROR
- 23 POLE AND SHELF
- 24 VANITY
- 25 PLANTER
- 26 NICHE
- 27 SKYLIGHT - See Roof Plan
- 28 STAIRWAYS / STEPS
- 29 GUARDRAIL
- 30 HANDRAIL
- 31 THRESHOLD
- 32 WASHER
- 33 DRYER
- 34 DRYER MOISTURE EXHAUST DUCT
- 35 STACKED WASHER DRYER COMBO
- 36 LAUNDRY SINK
- 37 GAS FIRED APPLIANCE CLOSET
- 38 PLUMBING ACCESS PANEL
- 39 EXTERIOR VENT
- 40 5/8" TYPE "X" GYP.
- 41 WATER SUB-METER w/ MANIFOLD
- 42 GAS METER w/ MANIFOLD

NOTE 1 - SMOKE DETECTORS: An approved smoke alarm shall be installed in each sleeping room & hallway or area giving access to a sleeping room, and on each story and basement for dwellings with more than one story. Smoke alarms shall be interconnected so that actuation of one alarm will activate all the alarms within the individual dwelling unit. In new construction smoke alarms shall receive their primary power source from the building wiring and shall be equipped with battery back up and low battery signal. (R314)

NOTE 2 - CARBON MONOXIDE DETECTORS: An approved carbon monoxide alarm shall be installed in dwelling units and in sleeping units within which fuel-burning appliances are installed and in dwelling units that have attached garages. Carbon monoxide alarm shall be provided outside of each separate dwelling unit sleeping area in the immediate vicinity of the bedroom(s) and on every level of a dwelling unit including basements. (R315)

NOTE 3: Each appliance provided and installed shall meet ENERGY STAR if an ENERGY STAR designation is applicable for that appliance.

NOTE 4: The flow rates for all plumbing fixtures shall comply with the minimum flow rates in Table 4.303.2 (see G-2.10)

NOTE 5: When single shower fixtures are served by more than one showerhead, the combined rate of all showerheads shall not exceed the maximum flow rates specified in the maximum allowable flow rate column contained in Table 4.303.2 or the shower shall be designed to only allow one showerhead to be in operation at a time. (see G-2.10 for Table 4.303.2)

Note 6: Heater shall be capable of maintaining a minimum room temperature of 68°F at a point 3 feet above the floor and 2 feet from the exterior walls in all habitable rooms at the design temperature.

Note 7: ENERGY REQUIREMENTS: See attached Forms CF-1R and MF-1R specifying the required energy features for wall/ceiling insulation, window areas and types, HVAC systems, duct insulation and testing, lighting type and switching, water heater type and pipe/heater insulation and HERS rater verification requirements. (form CF-6R required)

Note 8: FIRE BLOCKING REQUIREMENTS: Fire blocking shall be installed at:
 a. Concealed spaces of stud walls and partitions, floor and ceiling at 10'-0" max. intervals both vertically and horizontally;
 b. Interconnections between concealed vertical and horizontal spaces;
 c. Concealed space between stair stringers at top and bottom run;
 d. At openings around vents, pipes, ducts and chimneys (non-combustible materials);
 e. At openings between attic and chimney chase for factory-built chimneys.

	NEW PARTY WALL		ROOM NAME
	NEW WOOD FRAMED WALL		ROOM TAG
	DOWNSPOUT		WINDOW TAG
	MECHANICAL VENTILATION - CAPABLE OF PROVIDING 50 CFM.		LEVEL CHANGE
	SMOKE DETECTOR - see NOTE 1		ENLARGED DRAWING CALLOUT
	CARBON MONOXIDE DETECTOR - see NOTE 1		DIMENSION FINISHED FACE TO FINISHED FACE
	KEY NOTE		MINIMUM CLEAR DIMENSION
			DIMENSION FINISHED FACE TO CENTERLINE OF OPENING

KEY NOTES
NO SCALE 4

NOTES
NO SCALE 3

LEGEND
NO SCALE 1

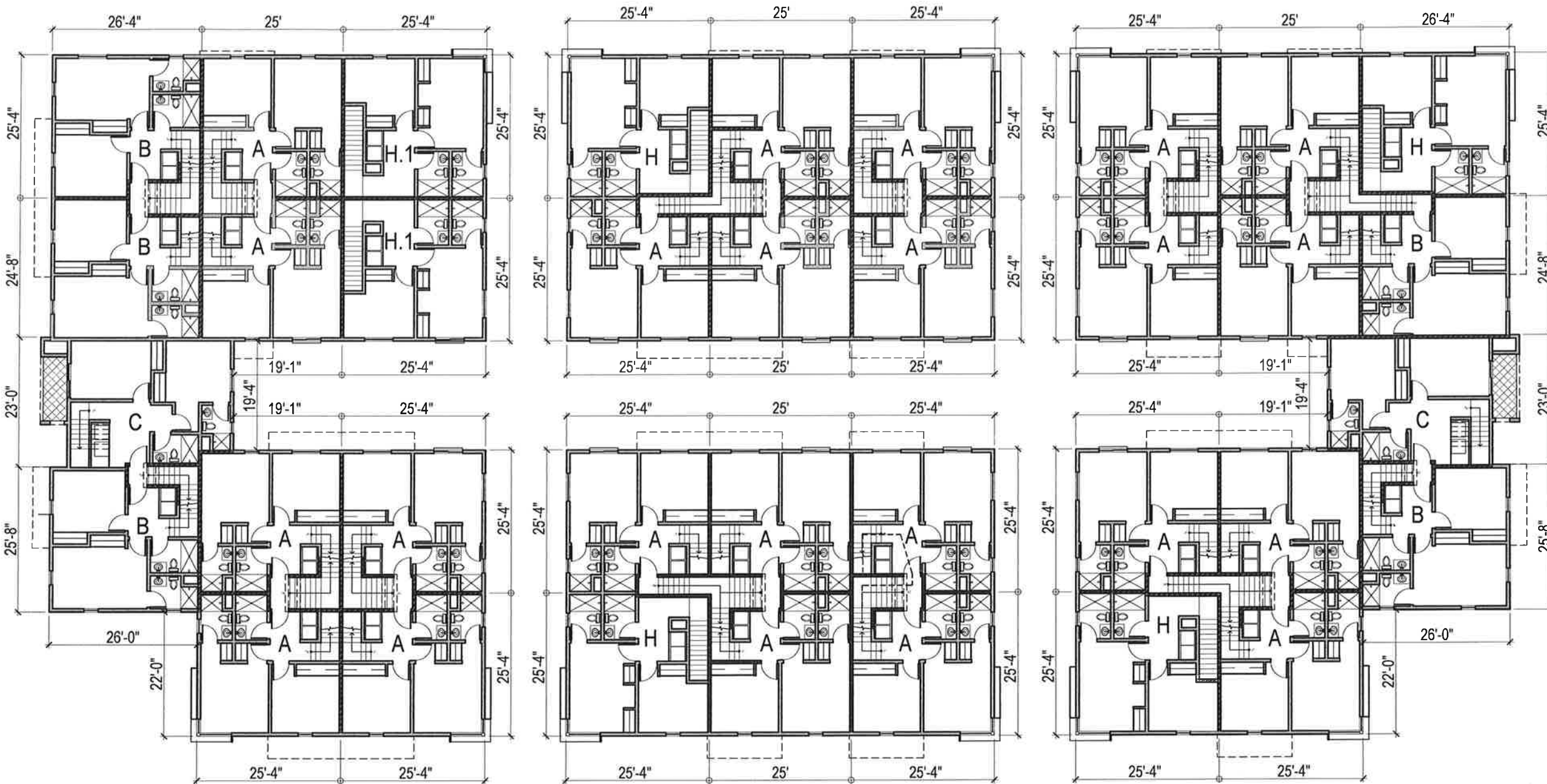

SECOND FLOOR PLAN
 $\frac{3}{32}'' = 1'-0''$ 2

- 1. GAS FURNACE
- 2. TANKLESS WATER HEATER
 a. by NORITZ
- 3. KITCHEN SINK
- 4. DISHWASHER
- 5. RANGE
- 6. COOK TOP
- 7. WALL OVEN
- 8. REFRIGERATOR FREEZER COMBO
- 9. REFRIGERATOR
- 10. FREEZER
- 11. KITCHEN HOOD
- 12. PANTRY w/ ADJUSTABLE SHELVES
- 13. 24" BASE CABINETS w/ 4" TOE SPACE
- 14. 14" UPPER CABINETS
- 15. 42" HIGH BAR
- 16. LAVATORY
 a. FAUCET - Maximum flow rate to be 1.8 gallons per minute
- 17. BUILT-IN MILLWORK
- 18. 22" BATHROOM BASE CABINET w/ 4" TOE SPACE
- 19. SHOWER
 a. Glass enclosure shall be tempered and shatter resistant when provided
 b. Min. 70" high non-absorbent wall adj. to shower
 c. Shower area to be minimum of 1024 s.f. with a 30" dia. clear turning radius.
 d. SHOWERHEAD - Maximum flow rate to be 2.0 gallons per minute
- 20. SHOWER BENCH
- 21. LOW CONSUMPTION WATER CLOSET
 - 15" min between water closet and any side wall
 - 24" clear space in front of water closet
- 22. MIRROR
- 23. POLE AND SHELF
- 24. VANITY
- 25. PLANTER
- 26. NICHE
- 27. SKYLIGHT - See Roof Plan
- 28. STAIRWAYS / STEPS:
 a. Min. 36" wide stairway and landings UO.N. - 1009.1
 b. Headroom clearance of not less than 6'-8" at tread nosing - 1009.2
 c. COMMERCIAL AND MULTIFAMILY: Max. 7" rise, min. 11" run for stairways - 1009.3
 d. SFD and contained within a dwelling unit: Max. 7.75" rise, Min. 10" run for stairways - 1009.3
 e. The largest rise or run in a flight of stairs may not exceed the smallest by more than 0.375" - 1009.3.2
 f. min. of 36"x36" landing - 1009.4.
- 29. GUARDRAIL
 a. Open guards shall have in terminal rails or ornamental patterns such that a 4-inch-diameter sphere cannot pass through any opening 1013.3
 b. Guards shall have a 42" min. height 1013.2
 c. Within a dwelling unit when the guardrail serves as hand rail too, they shall be not less than 34" and not more than 38" above the nosing 1013.2
- 30. HANDRAIL
 a. Required for 4 or more risers
 b. Top of handrails shall be 34" to 38" above tread nosing. 1012.2
 c. Handgrip portion of handrail shall not be less than 1 1/4" nor more 2" cross-sectional dimension having a smooth surface with no sharp corners. - 1012.3.
- 31. THRESHOLD
 a. Thresholds at doorways (1008.1.6) shall not exceed:
 - 0.75" in height for sliding doors;
 - 0.5" for other doors;
 Exception: The threshold height shall be limited to 7.75" where the door does not swing over the landing or step in a SFD.
- 32. WASHER
- 33. DRYER
- 34. DRYER MOISTURE EXHAUST DUCT
 a. 4" dia min, smooth, metal with back-draft damper (A flexible duct cannot extend more than 6 ft. and cannot be concealed)
- 35. STACKING WASHER DRYER COMBO
- 36. LAUNDRY SINK
- 37. GAS FIRED APPLIANCE CLOSET
 a. 100 sq. in. min. openings 18" w in 12" from floor & ceiling of the enclosure for combustion air. Doors serving the compartment shall be at least 24" wide
- 38. PLUMBING ACCESS PANEL
 a. 12"x12" min
 b. Required for bathtubs unless plumbing is without slip joints 405.2
- 39. EXTERIOR VENT
 a. Openings into floors, attics, or other enclosed areas shall not exceed 144 sq. inches and shall be covered w/ corrosion resist. metal mesh w/ mesh w/ max openings of 1/4" inch.
- 40. 5/8" TYPE "X" GYP
- 41. WATER SUB-METER w/ MANIFOLD
- 42. GAS METER w/ MANIFOLD

NOTE 1 - SMOKE DETECTORS: An approved smoke alarm shall be installed in each sleeping room & hallway or area giving access to a sleeping room, and on each story and basement for dwellings with more than one story. Smoke alarms shall be interconnected so that activation of one alarm will activate all the alarms within the individual dwelling unit. In new construction smoke alarms shall receive their primary power source from the building wiring and shall be equipped with battery back up and low battery signal. (R314)

NOTE 2 - CARBON MONOXIDE DETECTORS: An approved carbon monoxide alarm shall be installed in dwelling units and in sleeping units within which fuel-burning appliances are installed and in dwelling units that have attached garages. Carbon monoxide alarm shall be provided outside of each separate dwelling unit sleeping area in the immediate vicinity of the bedroom(s) and on every level of a dwelling unit including basements. (R315)

NOTE 3: Each appliance provided and installed shall meet ENERGY STAR if an ENERGY STAR designation is applicable for that appliance.

NOTE 4: The flow rates for all plumbing fixtures shall comply with the maximum flow rates in Table 4.303.2 (see G-2.10)

NOTE 5: When single shower fixtures are served by more than one showerhead, the combined rate of all showerheads shall not exceed the maximum flow rates specified in the maximum allowable flow rate column contained in Table 4.303.2 or the shower shall be designed to only allow one showerhead to be in operation at a time. (see G-2.10 for Table 4.303.2)

Note 6: Heater shall be capable of maintaining a minimum room temperature of 68°F at a point 3 feet above the floor and 2 feet from the exterior walls in all habitable rooms at the design temperature.

Note 7: ENERGY REQUIREMENTS: See attached Forms CF-1R and MF-1R specifying the required energy features for wall/ceiling insulation, window areas and types, HVAC systems, duct insulation and testing, lighting type and switching, water heater type and pipe/insulation and HERS rater verification requirements. (form CF-6R required)

Note 8: FIRE BLOCK REQUIREMENTS: Fire blocking shall be installed at:
 a. Concealed spaces of stud walls and partitions, floor and ceiling at 10'-0" max. intervals both vertically and horizontally;
 b. Interconnections between concealed vertical and horizontal spaces;
 c. Concealed space between stair stringers at top and bottom run;
 d. At openings around vents, pipes, ducts and chimneys (non-combustible materials);
 e. At openings between attic and chimney chase for factory-built chimneys.

	NEW PARTY WALL		ROOM NAME	ROOM TAG
	NEW WOOD FRAMED WALL			DOOR TAG
	DOWNSPOUT			WINDOW TAG
	MECHANICAL VENTILATION - CAPABLE OF PROVIDING 50 CFM.			LEVEL CHANGE
	-Newly installed bathroom exhaust fans shall be ENERGY STAR compliant and be ducted to terminate to the outside of the building (9.506.1)			ENLARGED DRAWING CALLOUT
	- Newly installed bathroom exhaust fans, not functioning as a component of a whole house ventilation system, must be controlled by a humidistat which shall be readily accessible (9.506.1)			DIMENSION FINISHED FACE TO FINISHED FACE
	SMOKE DETECTOR - see NOTE 1			MINIMUM CLEAR DIMENSION
	CARBON MONOXIDE DETECTOR - see NOTE 1			DIMENSION FINISHED FACE TO CENTERLINE OF OPENING
	KEY NOTE			

KEY NOTES
 NO SCALE 4

NOTES
 NO SCALE 3

LEGEND
 NO SCALE 1

A-1.20

L+V architects
2882 COTNER AVE., SUITE 303
LOS ANGELES, CA
90064
T: 310.914.5577
WWW.LVARCH.COM

THE URBAN - NEW APARTMENT COMPLEX
1033 W. 5th Street + 1046 W. 6th Street
Chico, CA 95928

TITLE: THIRD FLOOR PLAN
3/32" = 1'-0"
NOT FOR CONSTRUCTION

September 22, 2016

A-1.30

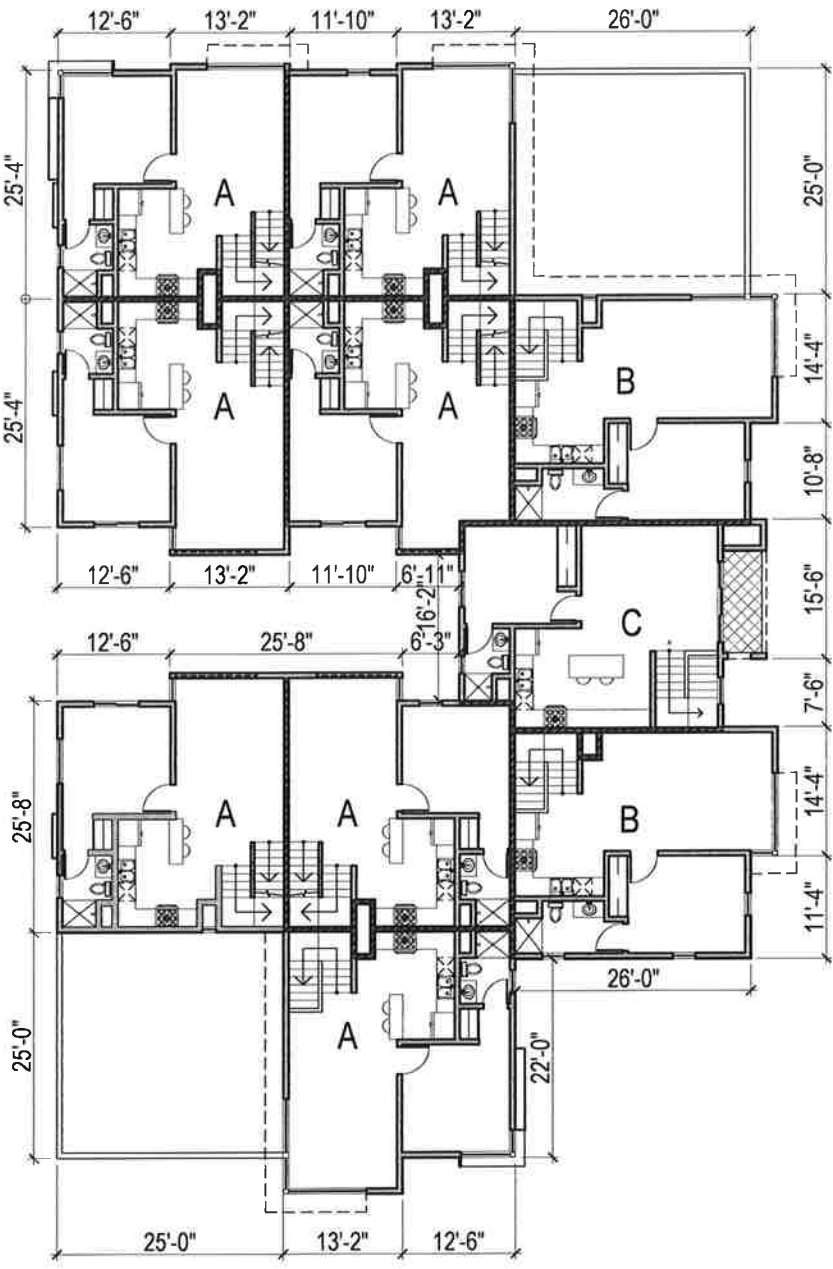
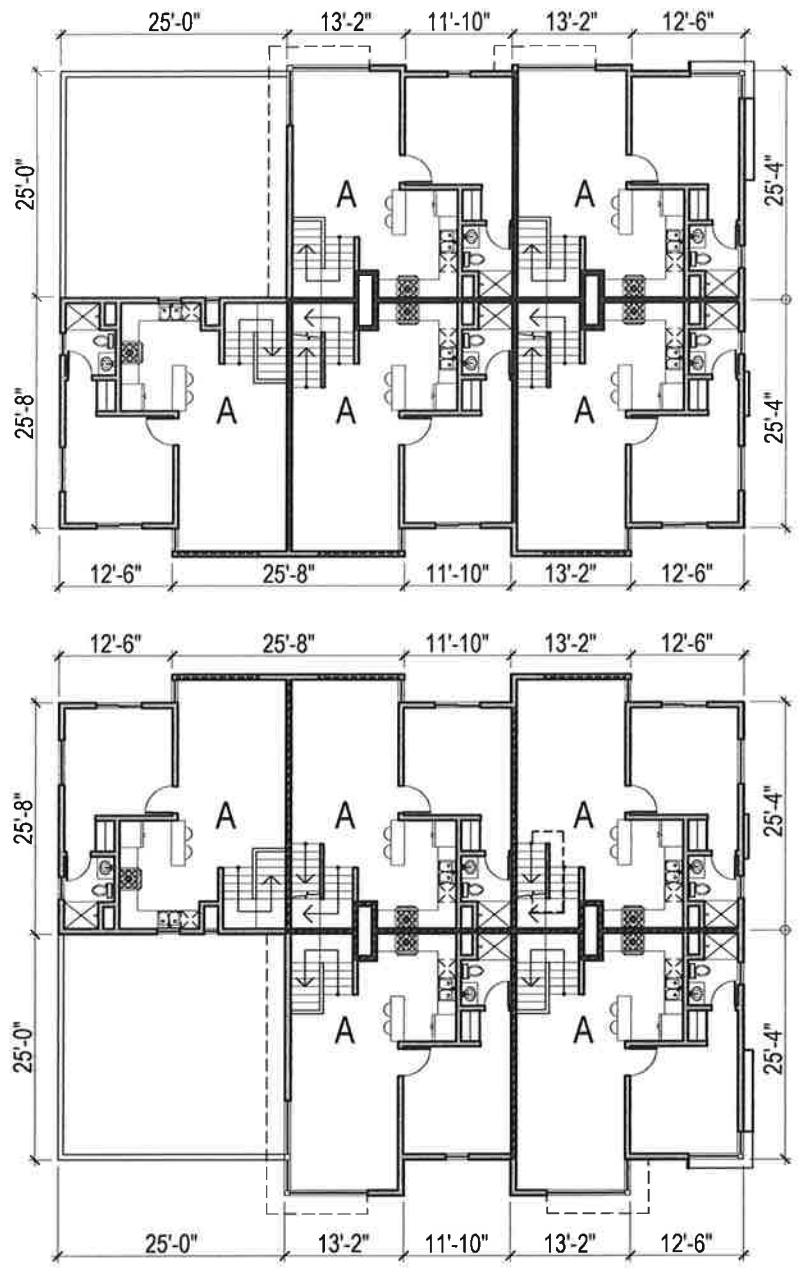
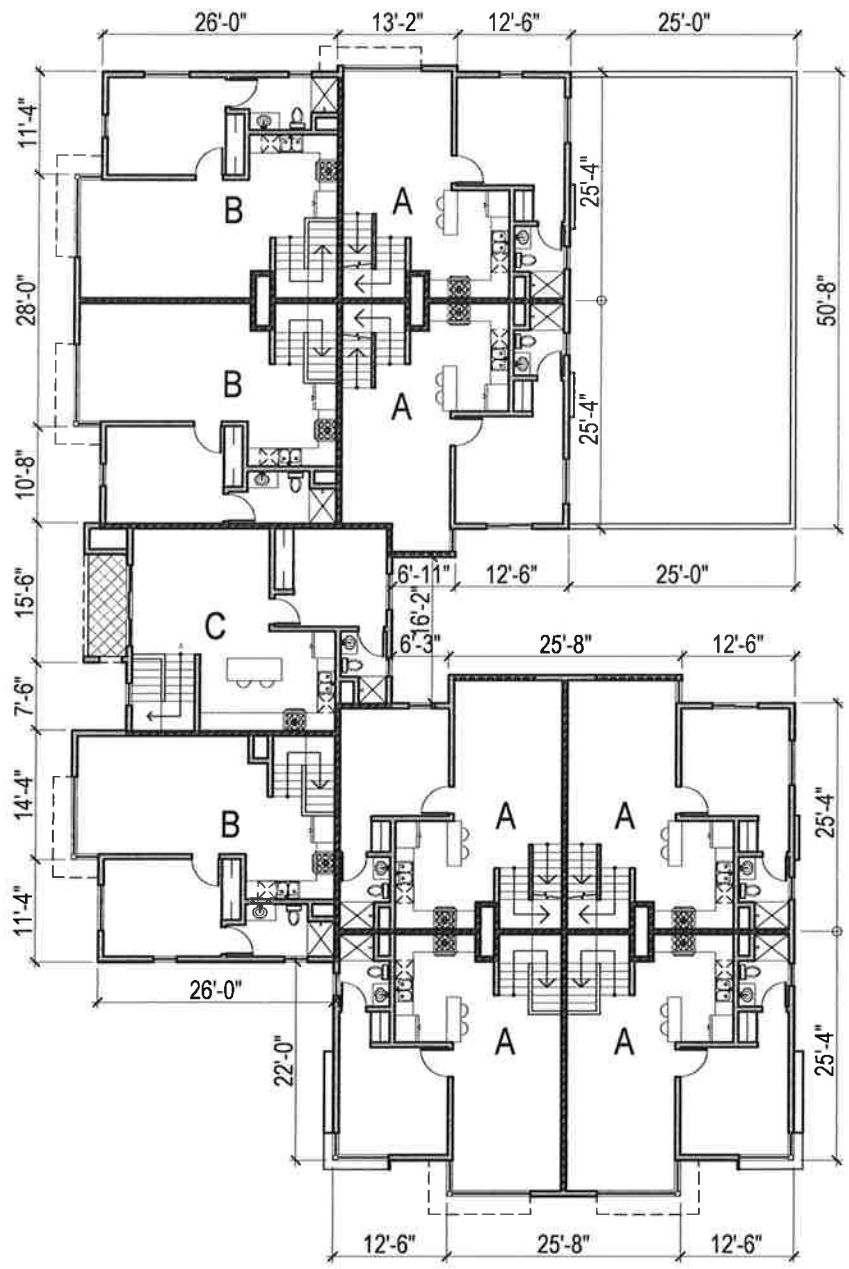

THIRD FLOOR PLAN
3/32" = 1'-0" 2

- 1 GAS FURNACE
- 2 TANKLESS WATER HEATER
a. by NORITZ
- 3 KITCHEN SINK
- 4 DISHWASHER
- 5 RANGE
- 6 COOK TOP
- 7 WALL OVEN
- 8 REFRIGERATOR FREEZER COMBO
- 9 REFRIGERATOR
- 10 FREEZER
- 11 KITCHEN HOOD
- 12 PANTRY w/ ADJUSTABLE SHELVES
- 13 24" BASE CABINETS w/ 4" TOE SPACE
- 14 14" UPPER CABINETS
- 15 42" HIGH BAR
- 16 LAVATORY
a. FAUCET - Maximum flow rate to be 1.8 gallons per minute
- 17 BUILT-IN MILL WORK
- 18 22" BATHROOM BASE CABINET w/ 4" TOE SPACE
- 19 SHOWER
a. Glass enclosure shall be tempered and shatter resistant when provided
b. Min. 70" high non-absorbent wall eq. to shower
c. Shower area to be minimum of 1024 sq. ft. with a 30" dia. clear turning radius
d. SHOWERHEAD - Maximum flow rate to be 2.0 gallons per minute
- 20 SHOWER BENCH
- 21 LOW CONSUMPTION WATER CLOSET
- 15" min between water closet and any side wall
- 24" clear space in front of water closet
- 22 MIRROR
- 23 POLE AND SHELF
- 24 VANITY
- 25 PLANTER
- 26 NICHE
- 27 SKYLIGHT - See Roof Plan
- 28 STARWAYS/ STEPS:
a. Min. 36" wide stairway and landings U.O.N. - 1009.1
b. Hoodroom clearance of not less than 6'-8" at tread nosing - 1009.2
c. COMMERCIAL AND MULTIFAMILY: Max. 7" rise, min. 11" run for stairways - 1009.3
d. SFD and contained within a dwelling unit: Max. 7.75" rise, Min. 10" run for stairways - 1009.3
e. The largest rise or run in a flight of stairs may not exceed the smallest by more than 0.375" - 1009.3.2
f. min. of 36"x36" landing - 1009.4.
- 29 GUARDRAIL
a. Open guards shall have intermediate rails or ornamental patterns such that a 4-inch-diameter sphere cannot pass through any opening 1013.3.
b. Guards shall have a 42" min. height 1013.2
c. Within a dwelling unit when the guardrail serves as hand rail too, they shall be not less than 34" and not more than 38" above the nosing 1013.2
- 30 HANDRAIL
a. Required for 4 or more risers
b. Top of handrails shall be 34" to 38" above tread nosing, 1012.2
c. Handgrip portion of handrail shall not be less than 1 1/4" nor more 2" cross-sectional dimension having a smooth surface with no sharp corners - 1012.3.
- 31 THRESHOLD
a. Thresholds at doorways (1008.1.6) shall not exceed:
- 0.75" in height for sliding doors;
- 0.5" for other doors.
Exception: The threshold height shall be limited to 7.75" where the door does not swing over the landing or step in a SFD
- 32 WASHER
- 33 DRYER
- 34 DRYER MOISTURE EXHAUST DUCT
a. 4" dia min, smooth, metal with back-draft damper (A flexible duct cannot extend more than 6 ft. and cannot be concealed)
- 35 STACKED WASHER DRYER COMBO
- 36 LAUNDRY SINK
- 37 GAS FIRED APPLIANCE CLOSET
a. 100 sq. in. min. openings T&B w/ in 12" from floor & ceiling of the enclosure for combustion air. Doors serving the compartment shall be at least 24" wide
- 38 PLUMBING ACCESS PANEL
a. 12"x12" min
b. Required for bathtubs unless plumbing is without slip joints 405.2
- 39 EXTERIOR VENT
a. Openings into floors, attics, or other enclosed areas shall not exceed 144 sq. inches and shall be covered w/ corrosion resist. metal mesh w/ mesh w/ max openings of 1/4" inch.
- 40 5/8" TYPE "K" GYP
- 41 WATER SUB-METER w/ MANIFOLD
- 42 GAS METER w/ MANIFOLD

KEY NOTES
NO SCALE 4

NOTE 1 - SMOKE DETECTORS: An approved smoke alarm shall be installed in each sleeping room & hallway or area giving access to a sleeping room, and on each story and basement for dwellings with more than one story. Smoke alarms shall be interconnected so that actuation of one alarm will activate all the alarms within the individual dwelling unit. In new construction smoke alarms shall receive their primary power source from the building wiring and shall be equipped with battery back up and low battery signal. (R314)

NOTE 2 - CARBON MONOXIDE DETECTORS: An approved carbon monoxide alarm shall be installed in dwelling units and in sleeping units within which fuel-burning appliances are installed and in dwelling units that have attached garages. Carbon monoxide alarm shall be provided outside of each separate dwelling unit sleeping area in the immediate vicinity of the bedroom(s) and on every level of a dwelling unit including basements. (R315)

Note 3: Each appliance provided and installed shall meet ENERGY STAR if an ENERGY STAR designation is applicable for that appliance

Note 4: The flow rates for all plumbing fixtures shall comply with the minimum flow rates in Table 4.303.2 (see G-2.10)

Note 5: When single shower fixtures are served by more than one showerhead, the combined rate of all showerheads shall not exceed the maximum flow rates specified in the maximum allowable flow rate column contained in Table 4.303.2 or the shower shall be designed to only allow one showerhead to be in operation at a time. (see G-2.10 for Table 4.303.2)

NOTES
NO SCALE 3

Note 6: Heater shall be capable of maintaining a minimum room temperature of 68°F at a point 3 feet above the floor and 2 feet from the exterior walls in all habitable rooms at the design temperature

Note 7: ENERGY REQUIREMENTS:
See attached Forms CF-1R and MF-1R specifying the required energy features for wall/ceiling insulation, window areas and types, HVAC systems, duct insulation and testing, lighting type and switching, water heater type and pipe/insulation and HERS rater verification requirements. (form CF-6R required)

Note 8: FIRE BLOCK REQUIREMENTS:
Fire blocking shall be installed at:
a. Concealed spaces of stud walls and partitions, floor and ceiling at 10'-0" max. intervals both vertically and horizontally;
b. Interconnections between concealed vertical and horizontal spaces;
c. Concealed space between stair stringers at top and bottom run;
d. At openings around vents, pipes, ducts and chimneys (non-combustible materials);
e. At openings between attic and chimney chase for factory-built chimneys.

	NEW PARTY WALL		ROOM NAME		ROOM TAG
	NEW WOOD FRAMED WALL		DOOR TAG		WINDOW TAG
	DOWNSPOUT		LEVEL CHANGE		ENLARGED DRAWING CALLOUT
	MECHANICAL VENTILATION - CAPABLE OF PROVIDING 50 CFM. - Newly installed bathroom exhaust fans shall be ENERGY STAR compliant and be ducted to terminate to the outside of the building (9.506.1) - Newly installed bathroom exhaust fans, not functioning as a component of a whole house ventilation system, must be controlled by a humidistat which shall be readily accessible (9.506.1)		DIMENSION FINISHED FACE TO FINISHED FACE		MINIMUM CLEAR DIMENSION
	SMOKE DETECTOR - see NOTE 1		DIMENSION FINISHED FACE TO CENTERLINE OF OPENING		
	CARBON MONOXIDE DETECTOR - see NOTE 1				
	KEY NOTE				

LEGEND
NO SCALE 1

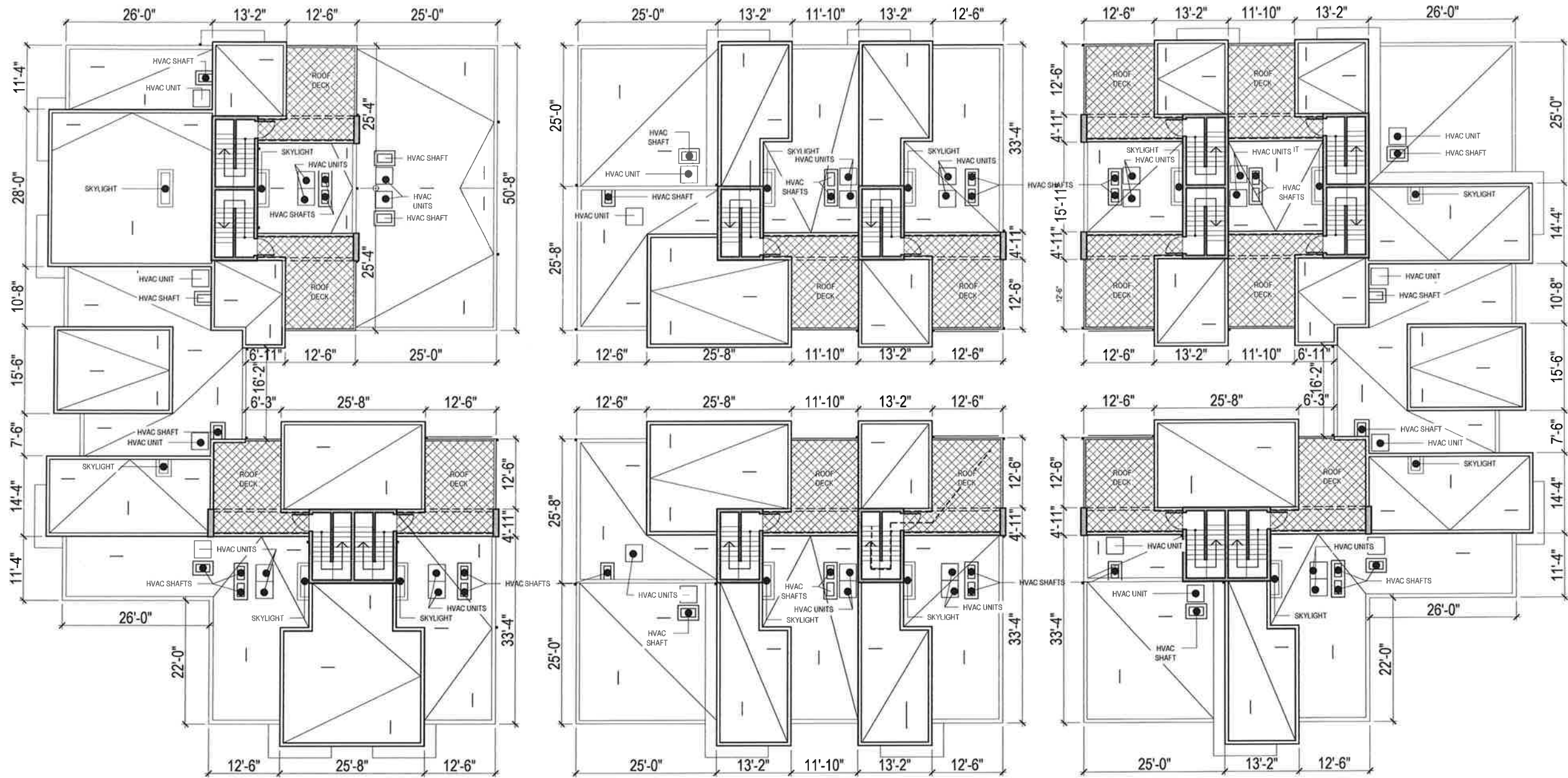

ROOF PLAN
3/32" = 1'-0"
2

- 1. GAS FURNACE
- 2. TANKLESS WATER HEATER
- 3. KITCHEN SINK
- 4. DISHWASHER
- 5. RANGE
- 6. COOK TOP
- 7. WALL OVEN
- 8. REFRIGERATOR FREEZER COMBO
- 9. REFRIGERATOR
- 10. FREEZER
- 11. KITCHEN HOOD
- 12. PANTRY w/ ADJUSTABLE SHELVES
- 13. 24" BASE CABINETS w/ 4" TOE SPACE
- 14. 14" UPPER CABINETS
- 15. 42" HIGH BAR
- 16. LAVATORY
- 17. BUILT-IN MILLWORK
- 18. 22" BATHROOM BASE CABINET w/ 4" TOE SPACE
- 19. SHOWER
- 20. SHOWER BENCH
- 21. LOW CONSUMPTION WATER CLOSET
- 22. MIRROR
- 23. POLE AND SHELF
- 24. VANITY
- 25. PLANTER
- 26. NICHE
- 27. SKYLIGHT - See Roof Plan
- 28. STAIRWAYS / STEPS
- 29. GUARDRAIL
- 30. HANDRAIL
- 31. THRESHOLD
- 32. WASHER
- 33. DRYER
- 34. DRYER MOISTURE EXHAUST DUCT
- 35. STACKED WASHER DRYER COMBO
- 36. LAUNDRY SINK
- 37. GAS FIRED APPLIANCE CLOSET
- 38. PLUMBING ACCESS PANEL
- 39. EXTERIOR VENT
- 40. 58" TYPE "X" GYP
- 41. WATER SUB-METER w/ MANIFOLD
- 42. GAS METER w/ MANIFOLD

NOTE 1 - SMOKE DETECTORS: An approved smoke alarm shall be installed in each sleeping room & hallway or area giving access to a sleeping room, and on each story and basement for dwellings with more than one story. Smoke alarms shall be interconnected so that actuation of one alarm will activate all the alarms within the individual dwelling unit. In new construction smoke alarms shall receive their primary power source from the building wiring and shall be equipped with battery back up and low battery signal. (R314)

NOTE 2 - CARBON MONOXIDE DETECTORS: An approved carbon monoxide alarm shall be installed in dwelling units and in sleeping units within which fuel-burning appliances are installed and in dwelling units that have attached garages. Carbon monoxide alarm shall be provided outside of each separate dwelling unit sleeping area in the immediate vicinity of the bedroom(s) and on every level of a dwelling unit including basements. (R315)

NOTE 3: Each appliance provided and installed shall meet ENERGY STAR if an ENERGY STAR designation is applicable for that appliance.

NOTE 4: The flow rates for all plumbing fixtures shall comply with the minimum flow rates in Table 4.303.2 (see G-2.10)

NOTE 5: When single shower fixtures are served by more than one showerhead, the combined rate of all showerheads shall not exceed the maximum flow rates specified in the maximum allowable flow rate column contained in Table 4.303.2 or the shower shall be designed to only allow one showerhead to be in operation at a time. (see G-2.10 for Table 4.303.2)

NOTE 6: Heater shall be capable of maintaining a minimum room temperature of 68°F at a point 3 feet above the floor and 2 feet from the exterior walls in all habitable rooms at the design temperature.

NOTE 7: ENERGY REQUIREMENTS: See attached Forms CF-1R and MF-1R specifying the required energy features for wall/ceiling insulation, window areas and types, HVAC systems, duct insulation and testing, lighting type and switching, water heater type and pipe/heater insulation and HERS rater verification requirements. (form CF-6R required)

NOTE 8: FIRE BLOCK REQUIREMENTS: Fire blocking shall be installed at:
 a. Concealed spaces of stud walls and partitions, floor and ceiling at 10'-0" max. intervals both vertically and horizontally;
 b. Interconnections between concealed vertical and horizontal spaces;
 c. Concealed space between stair stringers at top and bottom run;
 d. All openings around vents, pipes, ducts and chimneys (non-combustible materials);
 e. All openings between attic and chimney chase for factory-built chimneys

	NEW PARTY WALL		ROOM NAME		ROOM TAG
	NEW WOOD FRAMED WALL		DOOR TAG		WINDOW TAG
	DOWNSPOUT		LEVEL CHANGE		ENLARGED DRAWING CALLOUT
	MECHANICAL VENTILATION - CAPABLE OF PROVIDING 50 CFM.		DIMENSION FINISHED FACE TO FINISHED FACE		MINIMUM CLEAR DIMENSION
	SMOKE DETECTOR - see NOTE 1		DIMENSION FINISHED FACE TO CENTERLINE OF OPENING		
	CARBON MONOXIDE DETECTOR - see NOTE 1				
	KEY NOTE				

KEY NOTES
NO SCALE
4

NOTES
NO SCALE
3

LEGEND
NO SCALE
1

L+V architects
 2332 COTNER AVE, SUITE 303
 WEST LOS ANGELES, CA
 90064
 T: 310.914.6577
 WWW.LVARCH.COM

THE URBAN - NEW APARTMENT COMPLEX
 1033 W. 5th Street + 1046 W. 6th Street
 Chico, CA 95928

TITLE: ELEVATIONS

NOT FOR CONSTRUCTION

September 22, 2016

A-2.10



WEST ELEVATION RENDERING 3
 3/32" = 1'-0"

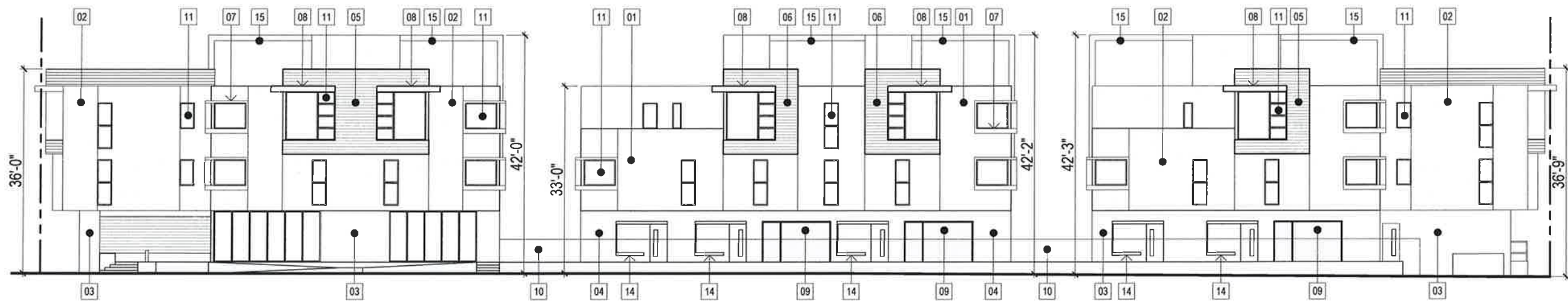

WEST ELEVATION 2
 3/32" = 1'-0"

EXTERIOR FINISHES

- EF-1 PLASTER - COLOR COAT
- EF-2 METAL FASCIA
- EF-3 PLASTER FOR PAINT
- EF-4 VINYL WINDOW PER SCHEDULE
- EF-5 PLASTER SOFFIT
- EF-6 SIDING
- EF-7 ALUMINUM REGLET

NOTE: REFER TO G-?..?? FOR FINISH SPECS AND MANUFACTURER INFORMATION

KEY NOTE	INFORMATION	FINISH REFERENCE
1	20/30 STUCCO - LIGHT GREY	EF-1
2	20/30 STUCCO - DARK GREY	EF-2
3	SMOOTH PLASTER - LIGHT GREY	EF-3
4	SMOOTH PLASTER - DARK GREY	EF-4
5	CORRUGATED METAL SIDING - LIGHT GREY	EF-5
6	CORRUGATED METAL SIDING - DARK GREY	EF-6
7	CORNER WINDOW FRAME - PLASTER	EF-7
8	EAVE W/ PERFORATED METAL ROOF	EF-8

9	BICYCLE ENCLOSURE	EF-8
10	WIRE-MESH FENCE - BLACK	PER LANDSCAPE ARCHITECT
11	VINYL WINDOW	EF-9
12	METAL GUARDRAIL	EF-10
13	JULIET BALCONY GUARDRAIL	EF-8
14	ENTRY BENCH W/ EAVE	EF-8
15	ROOF DECK TRELIS	EF-7
16	BALCONY VOLUMES	EF-7

NOTE: REFER TO 1 / A-6.20 FOR FINISH SPECS AND MANUFACTURER INFORMATION

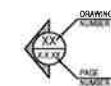

SECTION TAG

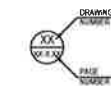

DETAIL TAG

ROOM NAME

ROOM TAG

TO DBL PL

SECTION / ELEVATION TAG



DETAIL / ENLARGED CLOUD

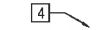

MATERIAL CALLOUT

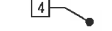

MATERIAL CALLOUT FIELD



DOOR TAG



WINDOW TAG



CHANGE OF LEVEL



EXIT / ENTRANCE

EXTERIOR FINISH LEGEND
 NO SCALE 5

EXTERIOR FINISH KEY NOTES
 NO SCALE 4

SYMBOLS LEGEND
 NO SCALE 1

L+V architects
 2332 COTNER AVE, SUITE 303
 WEST LOS ANGELES, CA
 TEL: 310.914.5577
 WWW.LVARCH.COM

THE URBAN - NEW APARTMENT COMPLEX
 1033 W. 5th Street + 1046 W. 6th Street
 Chico, CA 95928

TITLE: ELEVATIONS

NOT FOR CONSTRUCTION

September 22, 2016

A-2.20



EAST ELEVATION RENDERING
 $\frac{3}{32}'' = 1'-0''$ 3

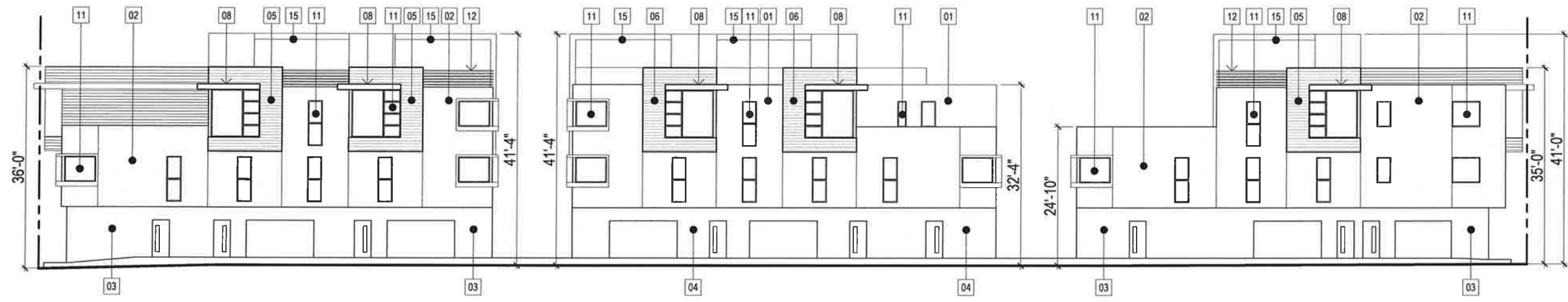

EAST ELEVATION
 $\frac{3}{32}'' = 1'-0''$ 2

- EXTERIOR FINISHES**
- EF-1 PLASTER - COLOR COAT
 - EF-2 METAL FASCIA
 - EF-3 PLASTER FOR PAINT
 - EF-4 VINYL WINDOW PER SCHEDULE
 - EF-5 PLASTER SOFFIT
 - EF-8 SIDING
 - EF-7 ALUMINUM REGLET
- NOTE: REFER TO G-1.?? FOR FINISH SPECS AND MANUFACTURER INFORMATION

KEY NOTE	INFORMATION	FINISH REFERENCE
1	20/30 STUCCO - LIGHT GREY	EF-1
2	20/30 STUCCO - DARK GREY	EF-2
3	SMOOTH PLASTER - LIGHT GREY	EF-3
4	SMOOTH PLASTER - DARK GREY	EF-4
5	CORRUGATED METAL SIDING - LIGHT GREY	EF-5
8	CORRUGATED METAL SIDING - DARK GREY	EF-6
7	CORNER WINDOW FRAME - PLASTER	EF-7
8	EAVE W/ PERFORATED METAL ROOF	EF-8

9	BICYCLE ENCLOSURE	EF-6
10	WIRE-MESH FENCE - BLACK	PER LANDSCAPE ARCHITECT
11	VINYL WINDOW	EF-9
12	METAL GUARDRAIL	EF-10
13	JULIET BALCONY GUARDRAIL	EF-8
14	ENTRY BENCH W/ EAVE	EF-8
15	ROOF DECK TRELLIS	EF-7
16	BALCONY VOLUMES	EF-7

NOTE: REFER TO 1 / A-6.20 FOR FINISH SPECS AND MANUFACTURER INFORMATION

SECTION TAG

DETAIL TAG

ROOM TAG

SECTION / ELEVATION TAG

DETAIL / ENLARGED CLOUD

MATERIAL CALLOUT

MATERIAL CALLOUT FIELD

DOOR TAG

WINDOW TAG

CHANGE OF LEVEL

EXIT / ENTRANCE

EXTERIOR FINISH LEGEND
 NO SCALE 5

EXTERIOR FINISH KEY NOTES
 NO SCALE 4

SYMBOLS LEGEND
 NO SCALE 1



NORTH ELEVATION RENDERING
3/32" = 1'-0" 6



SOUTH ELEVATION RENDERING
3/32" = 1'-0" 3

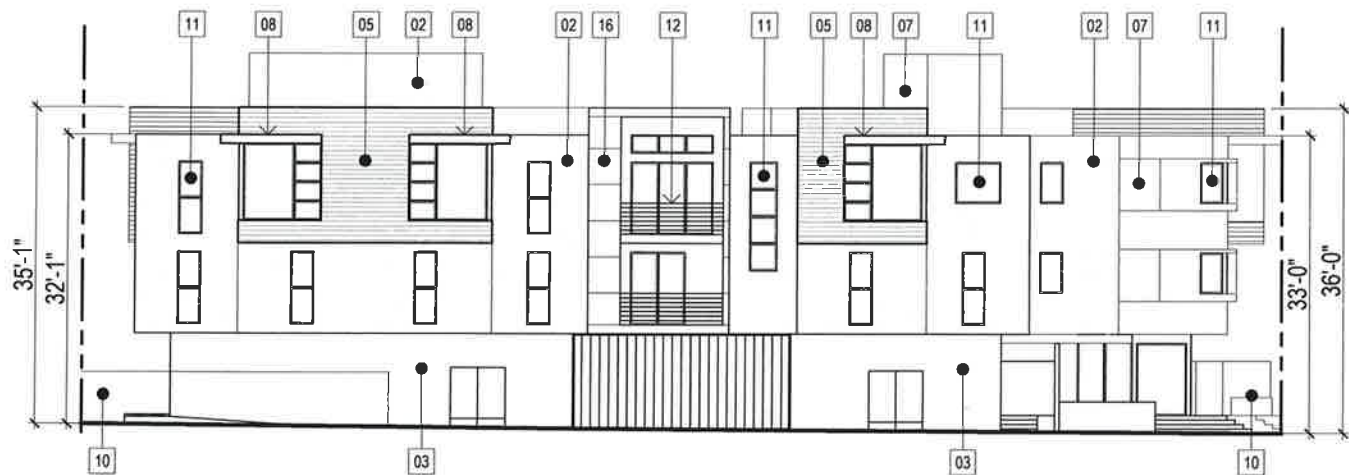

NORTH ELEVATION
3/32" = 1'-0" 5

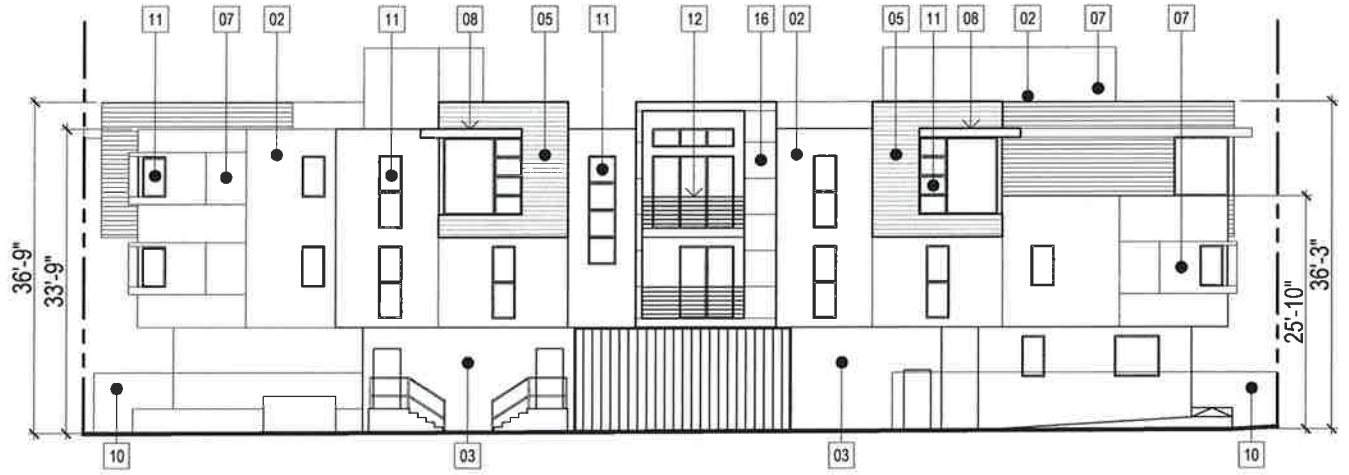

SOUTH ELEVATION
3/32" = 1'-0" 2

EXTERIOR FINISHES

- EF-1 PLASTER - COLOR COAT
- EF-2 METAL FASCIA
- EF-3 PLASTER FOR PAINT
- EF-4 VINYL WINDOW PER SCHEDULE
- EF-5 PLASTER SOFFIT
- EF-6 SIDING
- EF-7 ALUMINUM REGLET

NOTE: REFER TO G-2.?? FOR FINISH SPECS AND MANUFACTURER INFORMATION

KEY NOTE	INFORMATION	FINISH REFERENCE
1	20/30 STUCCO - LIGHT GREY	EF-1
2	20/30 STUCCO - DARK GREY	EF-2
3	SMOOTH PLASTER - LIGHT GREY	EF-3
4	SMOOTH PLASTER - DARK GREY	EF-4
5	CORRUGATED METAL SIDING - LIGHT GREY	EF-5
6	CORRUGATED METAL SIDING - DARK GREY	EF-6
7	CORNER WINDOW FRAME - PLASTER	EF-7
8	EAVE W/ PERFORATED METAL ROOF	EF-8

9	BICYCLE ENCLOSURE	EF-9
10	WIRE-MESH FENCE - BLACK	PER LANDSCAPE ARCHITECT
11	VINYL WINDOW	EF-9
12	METAL GUARDRAIL	EF-10
13	JULIET BALCONY GUARDRAIL	EF-8
14	ENTRY BENCH W/ EAVE	EF-8
15	ROOF DECK TRELIS	EF-7
16	BALCONY VOLUMES	EF-7

NOTE: REFER TO 1 / A-6.20 FOR FINISH SPECS AND MANUFACTURER INFORMATION

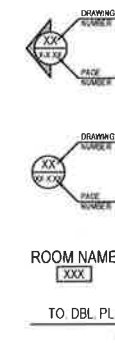

SECTION TAG
DETAIL TAG
ROOM TAG
SECTION / ELEVATION TAG

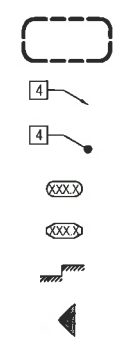

DETAIL / ENLARGED CLOUD
MATERIAL CALLOUT
MATERIAL CALLOUT FIELD
DOOR TAG
WINDOW TAG
CHANGE OF LEVEL
EXIT / ENTRANCE

EXTERIOR FINISH LEGEND
NO SCALE 7

EXTERIOR FINISH KEY NOTES
NO SCALE 4

SYMBOLS LEGEND
NO SCALE 1

TITLE: ELEVATIONS

September 22, 2016

NOT FOR CONSTRUCTION

THE URBAN - NEW APARTMENT COMPLEX
1033 W. 5th Street + 1046 W. 6th Street
Chicago, CA 95928

L+V architects
232 COTNER AVE, SUITE 303
WEST LOS ANGELES, CA
T: 310.914.6577
WWW.LVARCH.COM

A-2.30



COURTYARD ELEVATION RENDERING 3
3/32" = 1'-0"

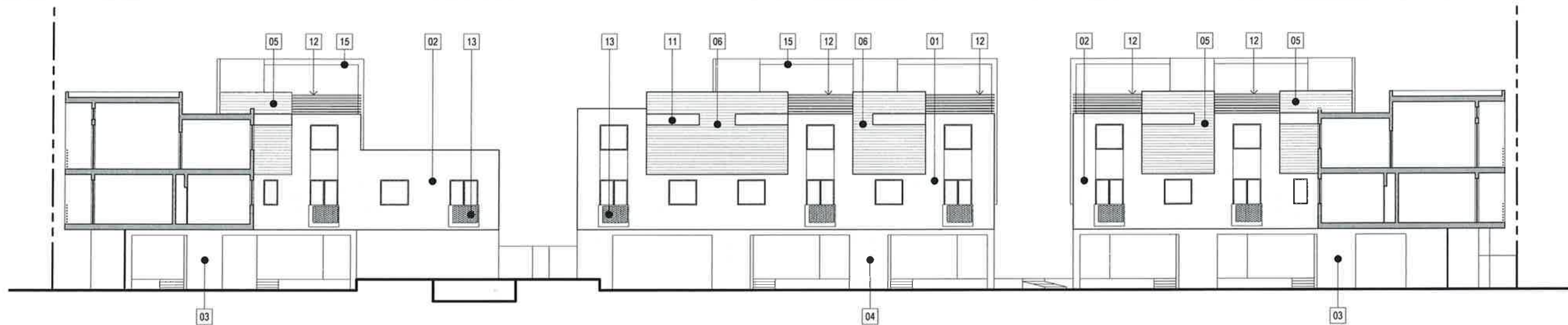

COURTYARD ELEVATION 2
3/32" = 1'-0"

EXTERIOR FINISHES

- EF-1 PLASTER - COLOR COAT
- EF-2 METAL FASCIA
- EF-3 PLASTER FOR PAINT
- EF-4 VINYL WINDOW PER SCHEDULE
- EF-5 PLASTER SOFFIT
- EF-6 SIDING
- EF-7 ALUMINUM REGLET

NOTE: REFER TO G-7.?? FOR FINISH SPECS AND MANUFACTURER INFORMATION

KEY NOTE	INFORMATION	FINISH REFERENCE
1	20/30 STUCCO - LIGHT GREY	EF-1
2	20/30 STUCCO - DARK GREY	EF-2
3	SMOOTH PLASTER - LIGHT GREY	EF-3
4	SMOOTH PLASTER - DARK GREY	EF-4
5	CORRUGATED METAL SIDING - LIGHT GREY	EF-5
6	CORRUGATED METAL SIDING - DARK GREY	EF-6
7	CORNER WINDOW FRAME - PLASTER	EF-7
8	EAVE W/ PERFORATED METAL ROOF	EF-8

9	BICYCLE ENCLOSURE	EF-8
10	WIRE-MESH FENCE - BLACK	PER LANDSCAPE ARCHITECT
11	VINYL WINDOW	EF-9
12	METAL GUARDRAIL	EF-10
13	JULIET BALCONY GUARDRAIL	EF-8
14	ENTRY BENCH W/ EAVE	EF-8
15	ROOF DECK TRELIS	EF-7
16	BALCONY VOLUMES	EF-7

NOTE: REFER TO 1 / A-6.20 FOR FINISH SPECS AND MANUFACTURER INFORMATION

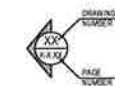

SECTION TAG

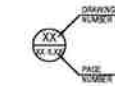

DETAIL TAG

ROOM NAME
XXX

ROOM TAG

TO DBL PL

SECTION / ELEVATION TAG



DETAIL / ENLARGED CLOUD



MATERIAL CALLOUT



MATERIAL CALLOUT FIELD



DOOR TAG



WINDOW TAG



CHANGE OF LEVEL



EXIT / ENTRANCE

EXTERIOR FINISH LEGEND 5
NO SCALE

EXTERIOR FINISH KEY NOTES 4
NO SCALE

SYMBOLS LEGEND 1
NO SCALE

L+V architects
2332 COTNER AVE, SUITE 303
WEST LOS ANGELES, CA
90024
T: 310.914.5577
WWW.LVARCH.COM

THE URBAN - NEW APARTMENT COMPLEX
1033 W. 5th Street + 1046 W. 6th Street
Chico, CA 95928

TITLE: ELEVATIONS
NOT FOR CONSTRUCTION

September 22, 2016

A-2.40

RECEIVED

AUG 23 2016

CITY OF CHICO
PLANNING SERVICES 2016-08.22

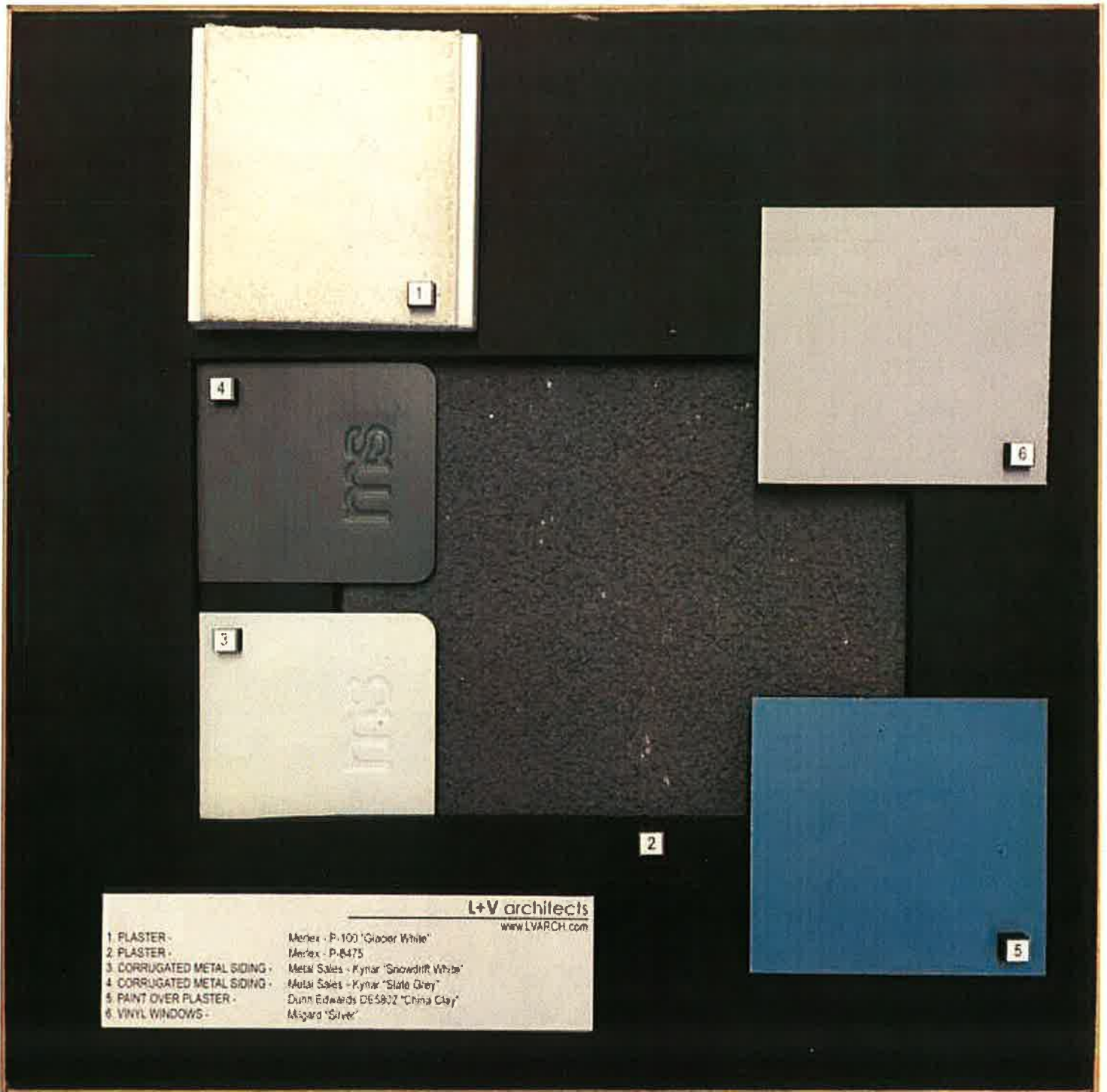

New Apartment Complex
1033 W. 5th Street & 1046 W. 6th Street
Chico, Ca 95928

Material Board

Attachment F

RECEIVED

AUG 23 2016

CITY OF CHICO
PLANNING SERVICES

2016-08.22

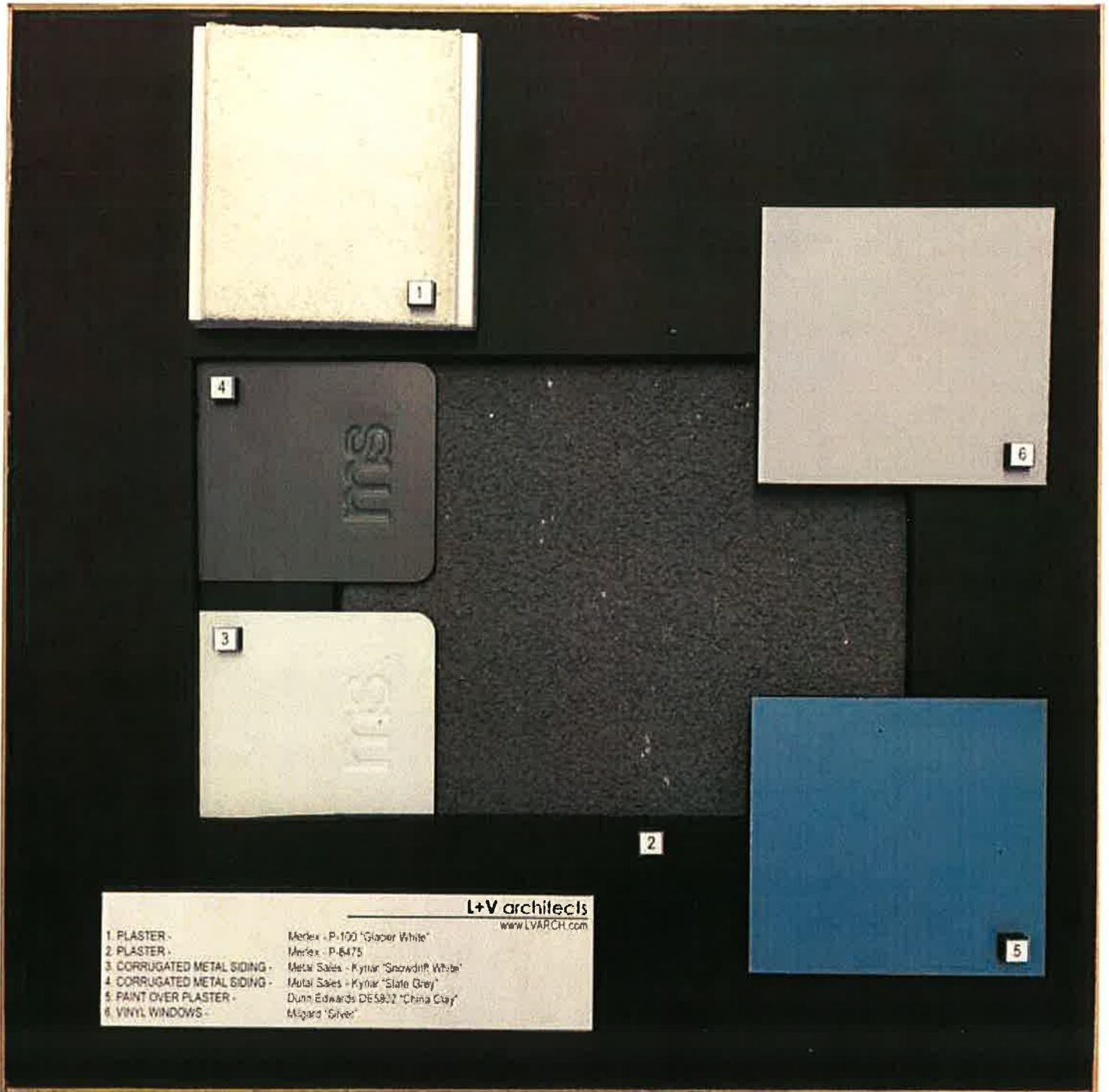

New Apartment Complex
1033 W. 5th Street & 1046 W. 6th Street
Chico, Ca 95928

Material Board

Attachment F

RECEIVED

AUG 23 2016

CITY OF CHICO
PLANNING SERVICES

2016-08.22

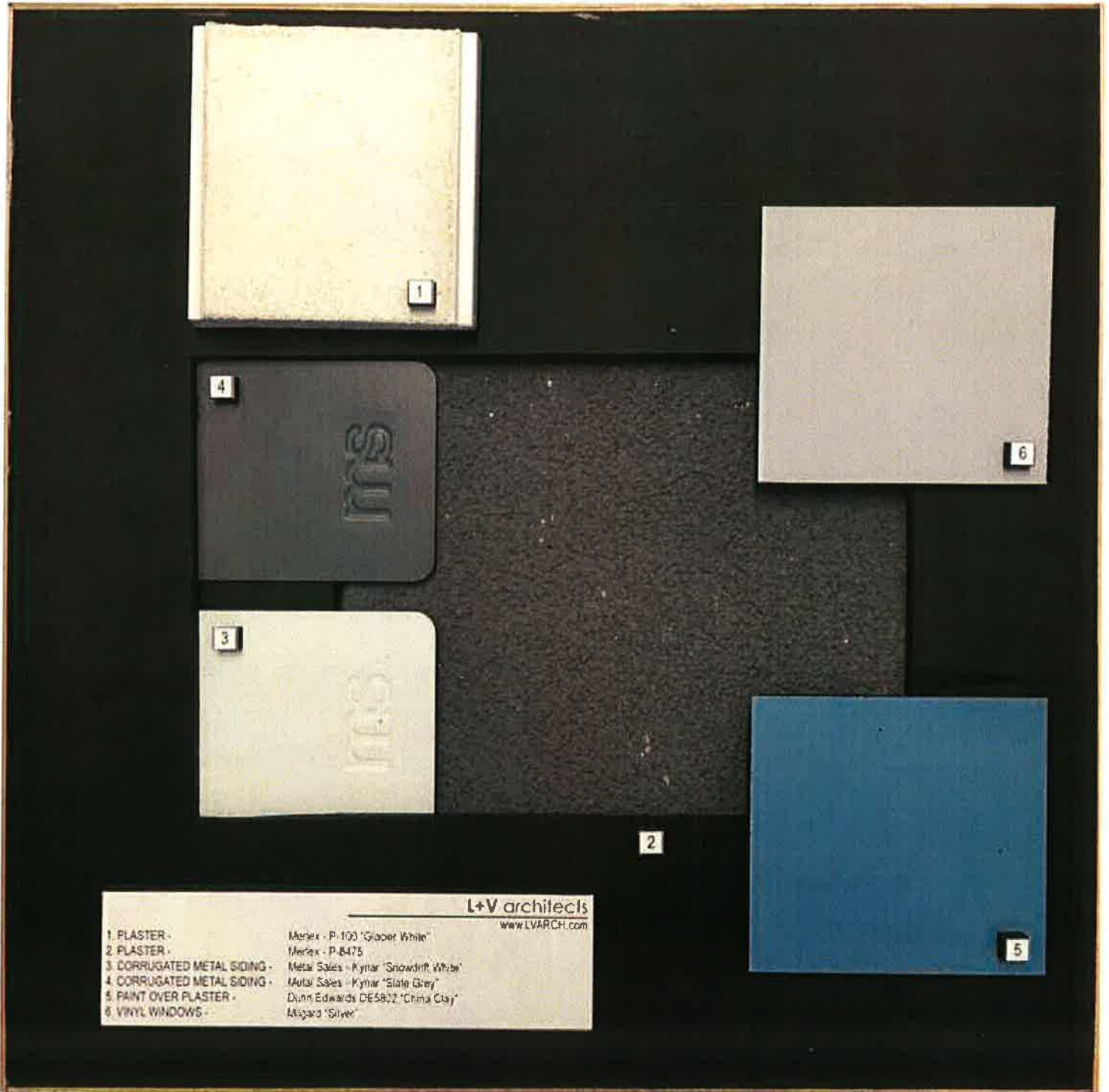

New Apartment Complex
1033 W. 5th Street & 1046 W. 6th Street
Chico, Ca 95928

Material Board

Attachment F

RECEIVED

AUG 23 2016

CITY OF CHICO
PLANNING SERVICES 2016-08.22

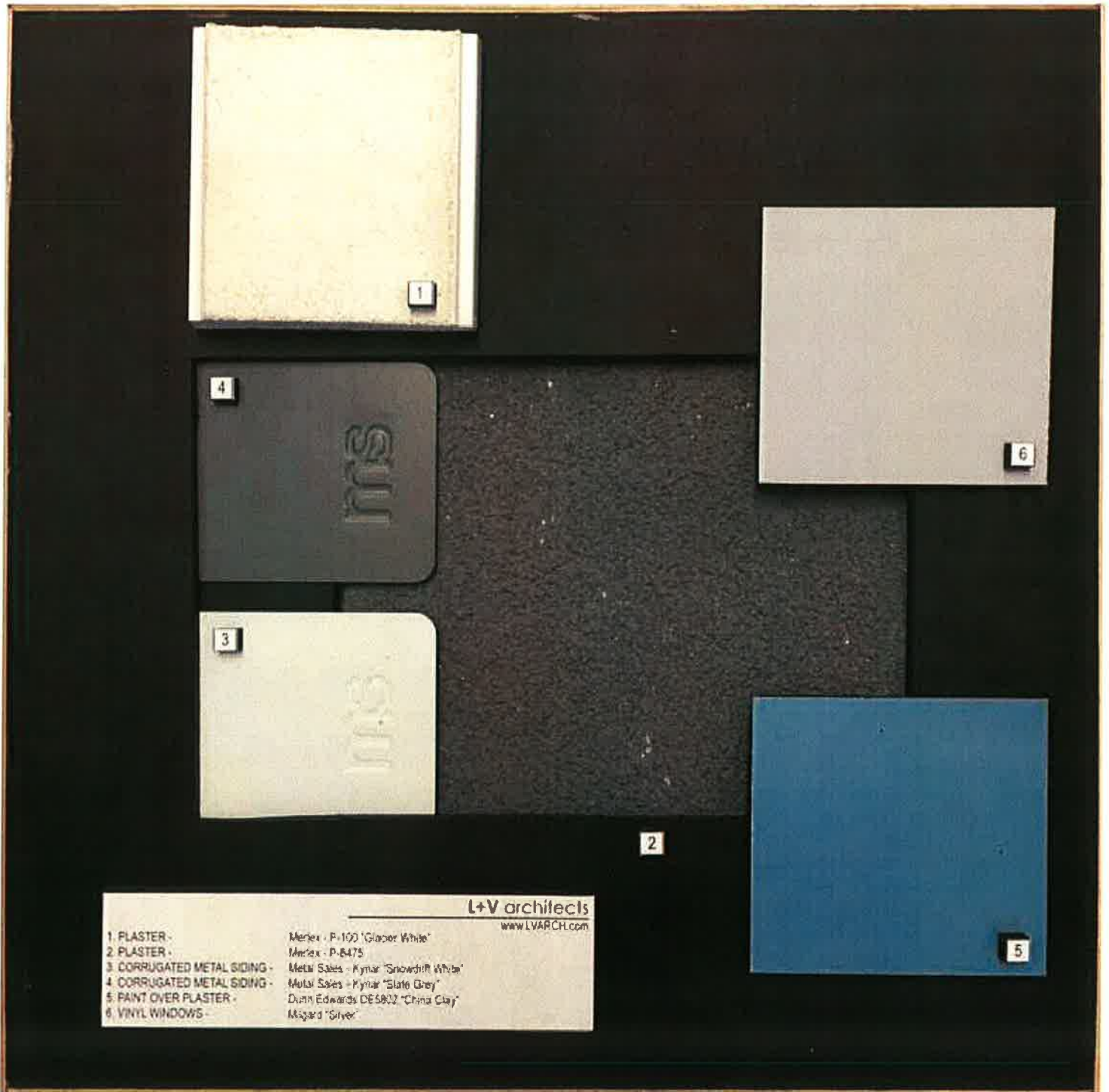

New Apartment Complex
1033 W. 5th Street & 1046 W. 6th Street
Chico, Ca 95928

Material Board

Attachment F



PROJECT
 1033 WEST 5TH ST
 +
 1046 WEST 6TH ST
 CHICO, CALIFORNIA

SHEET TITLE
 HARDSCAPE PLAN

ISSUE
 1 08-08-16 PLANNING SUBMITTAL

PHASE
 Landscape Plan
 (Site Design &
 Architectural Review)

ORIGIN DATE 07-11-16
 PLOT DATE 08-08-16
 DRAWN BY: TP
 CHECKED BY: DG

SHEET 3 of 9

L-1.0

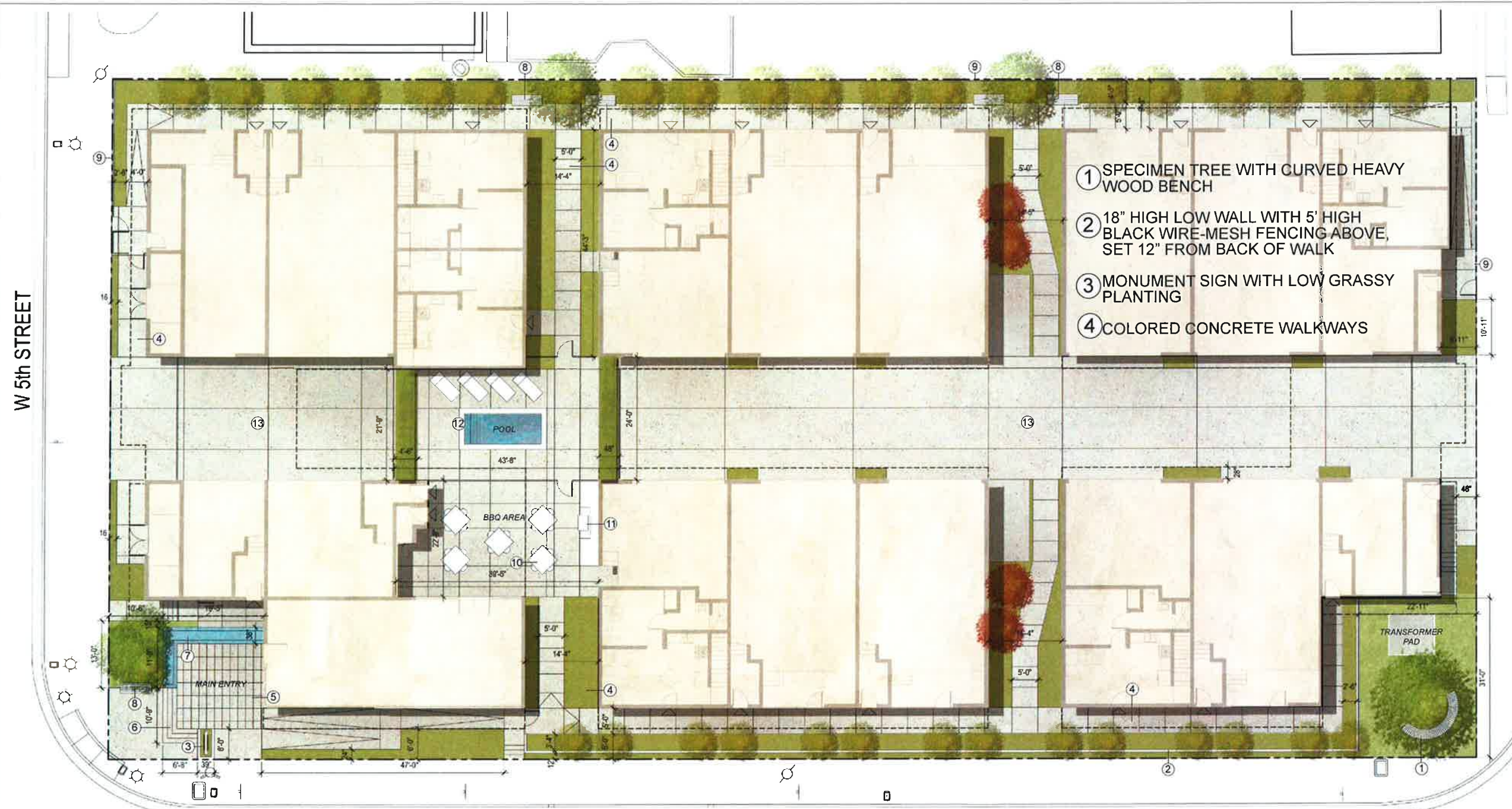

W 5th STREET

WALNUT STREET (STATE HIGHWAY 32)



- ⑤ ARCHITECTURALLY SCORED COLORED CONCRETE PAVING @ MAIN ENTRY
- ⑥ COLORED CONCRETE CORNER STEPS @ MAIN ENTRY
- ⑦ INFINITY EDGE WATER FEATURE
- ⑧ HEAVY WOOD BENCH SEATING
- ⑨ 5' HIGH BLACK WIRE-MESH FENCING
- ⑩ CAFE SEATING AT BBQ AREA
- ⑪ BARBEQUE WITH GRILL AND COUNTERTOP
- ⑫ SMALL SPA POOL WITH CHAISE LOUNGE SEATING AND ARCHITECTURALLY SCORED COLORED CONCRETE POOL DECK
- ⑬ COLORED CONCRETE DRIVEWAY PAVING

SCALE: 1/8" = 1'-0"

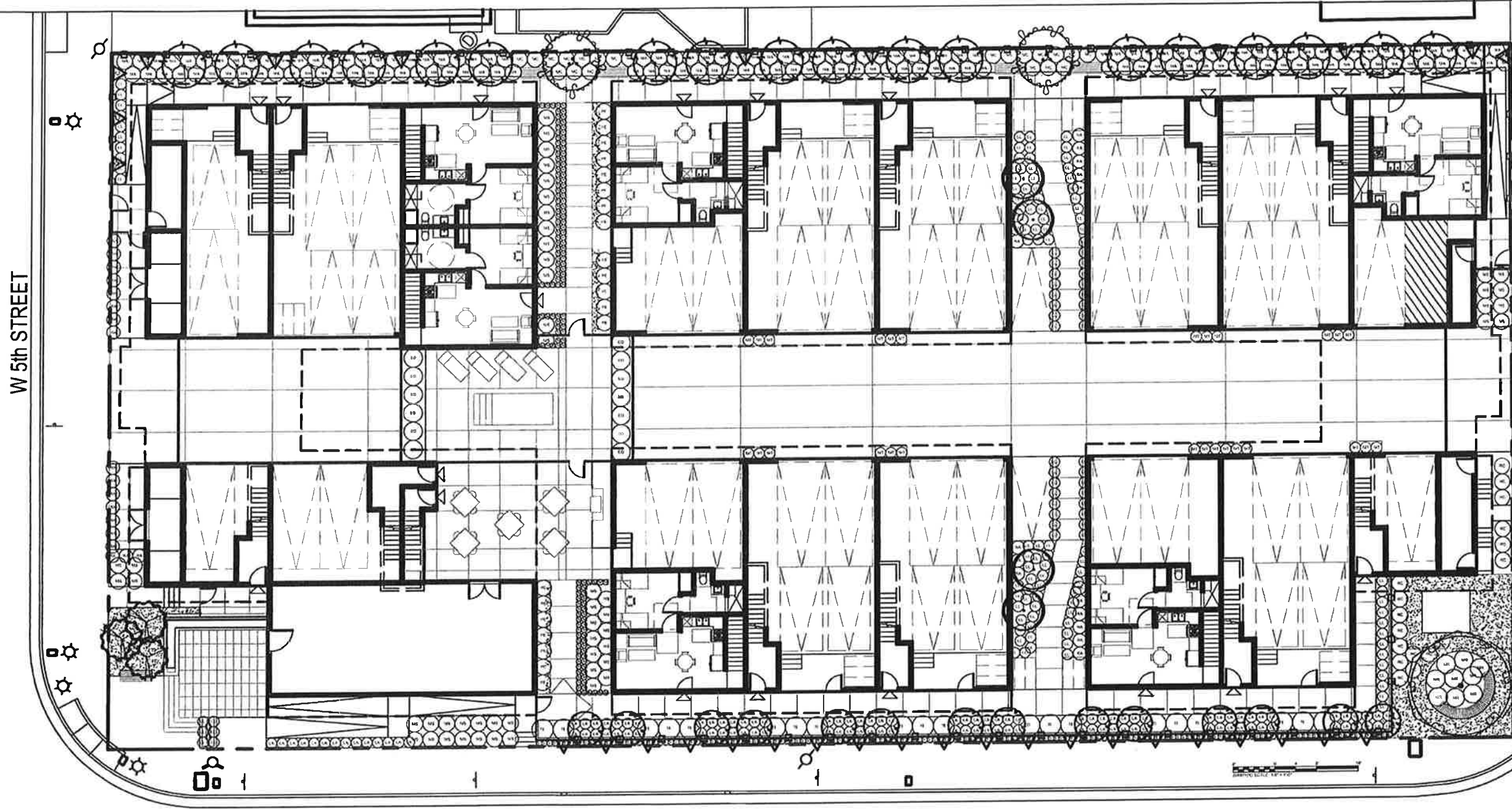

NOTE:
 SOIL TYPES INCLUDE SC(CLAYEY SAND SOIL,
 GC(GLAYEY GRAVEL SOIL), CL(LOW PLASTICITY CLAY
 SOIL), AND SM(SILTY SAND SOIL).

 THERE IS NO INDICATION THAT THE SOILS WILL
 REQUIRE SPECIAL PLANTING TECHNIQUES.

 THE TYPE OF SOIL IS SUITABLE FOR AL OF THE
 PROPOSED PLANTS IN THIS LANDSCAPE.

SCALE: 1/8" = 1'-0"



PROJECT
 1033 WEST 5TH ST
 +
 1046 WEST 6TH ST
 CHICO, CALIFORNIA

SHEET TITLE
 PLANTING PLAN

ISSUE
 1 08.08.16 PLANNING SUBMITTAL

PHASE
 Landscape Plan
 (Site Design &
 Architectural Review)

ORIGIN DATE 07-11-16
 PLOT DATE 08-08-16
 DRAWN BY: TP
 CHECKED BY: DG

SHEET 4 of 9

L-2.0B

TREE LEGEND

SYMBOL	PLANT NAME	QUANT.	SIZE	REFERENCE	WUCOLS
	ARBUTUS 'MARINA' MARINA STRAWBERRY TREE	2	24" BOX MULTI UPRIGHT	DETAIL 'A' SHEET L-2.1	LOW 0.2
	CERCIS OCCIDENTALIS WESTERN REDBUD	4	24" BOX	DETAIL 'A' SHEET L-2.1	VERY LOW 0.1
	LAURUS 'SARATOGA' SARATOGA SWEET BAY	18	24" BOX STD TRUNK	DETAIL 'A' SHEET L-2.1	LOW 0.2
	OLEA EUROPAEA 'SWAN HILL' FRUITLESS OLIVE TREE	14	24" BOX STD TRUNK	DETAIL 'A' SHEET L-2.1	VERY LOW 0.1
	PLATANUS ACERIFOLIA LONDON PLANE TREE (PLANT ALL TOGETHER)	3	36" BOX STD TRUNK	DETAIL 'A' SHEET L-2.1	MED 0.4
	QUERCUS AGRIFOLIA COAST LIVE OAK	1	36" BOX MULTI- TRUNK	DETAIL 'A' SHEET L-2.1	VERY LOW 0.1

VINE LEGEND

SYMBOL	PLANT NAME	QUANT.	SIZE	REFERENCE	WUCOLS
	CLYTOSTOMA CALLISTEGIOIDES LAVENDER TRUMPET VINE (ATTACH TO FENCE)	32	5 GAL. STAKE 8'-0" OC	DETAIL 'D' SHEET L-2.1	MED 0.5

GROUND COVER LEGEND

SYMBOL	PLANT NAME	QUANT.	SIZE	SPACE	REFERENCE	WUCOLS
	'NO-MOW' FESCUE SOD	CCQ	SOD	---	---	MED 0.6

CCQ: CONTRACTOR TO COMPUTE QUANTITY

SHRUB LEGEND

SYMBOL	PLANT NAME	QUANT.	SIZE	REFERENCE	WUCOLS
	ELAEOCARPUS DECIPIENS JAPANESE BLUEBERRY TREE (COLUMN FORM)	13	15 GAL. @ 42" OC	DETAIL 'B' & 'C' SHEET L-2.1	MED 0.5
	FESTUCA GLAUCA 'ELIJAH BLUE' ELIJAH BLUE FESCUE	162	1 GAL. @ 12" OC	DETAIL 'B' & 'C' SHEET L-2.1	LOW 0.2
	LAVANDULA ANGUSTIFOLIA ENGLISH LAVENDER (DOUBLE ROW)	110	5 GAL. @ 24" OC	DETAIL 'B' & 'C' SHEET L-2.1	LOW 0.2
	LOMANDRA LONGIFOLIA 'BREEZE' DWARF MAT RUSH	138	5 GAL. @ 24" OC	DETAIL 'B' & 'C' SHEET L-2.1	LOW 0.2
	MYRTUS COMMUNIS 'COMPACTA' DWARF MYRTLE	150	1 GAL. @ 12" OC	DETAIL 'B' & 'C' SHEET L-2.1	LOW 0.2
	MAHONIA REPENS CREEPING MAHONIA	146	5 GAL. @ 36" OC	DETAIL 'B' & 'C' SHEET L-2.1	LOW 0.2
	MUHLENBERGIA CAPILLARIS 'LENCA' REGAL MIST PINK MUHLY	22	5 GAL. @ 36" OC	DETAIL 'B' & 'C' SHEET L-2.1	LOW 0.2
	MUHLENBERGIA RIGENS DEER GRASS	9	5 GAL. @ 42" OC	DETAIL 'B' & 'C' SHEET L-2.1	LOW 0.2
	MISCANTHUS SINENSIS VAR. CONDENSATUS 'CABARET' CABARET JAPANESE SILVER GRASS	52	5 GAL. @ 36" OC	DETAIL 'B' & 'C' SHEET L-2.1	MED 0.5
	MISCANTHUS TRANSMORRISONENSIS EVERGREEN MISCANTHUS	27	5 GAL. @ 24" OC	DETAIL 'B' & 'C' SHEET L-2.1	MED 0.5
	PODOCARPUS ELONGATUS 'MONMAL' ICEE BLUE YELLOW-WOOD (COLUMN FORM)	20	15 GAL. @ 36" OC	DETAIL 'B' & 'C' SHEET L-2.1	MED 0.5
	RHAMNUS ALATERNUS ITALIAN BUCKTHORN (COLUMN FORM)	35	5 GAL. @ 30" OC	DETAIL 'B' & 'C' SHEET L-2.1	LOW 0.3
	RHAMNUS CALIFORNICA 'EVE CASE' COFFEEBERRY	16	5 GAL. @ 36" OC	DETAIL 'B' & 'C' SHEET L-2.1	LOW 0.3
	THAMNOCHORTUS INSIGNIS THATCHING REED	20	5 GAL. @ 48" OC	DETAIL 'B' & 'C' SHEET L-2.1	LOW 0.3

SCALE: 1/8" = 1'-0"



Arbutus 'Marina'
Marina Strawberry Tree



Cercis occidentalis
Western Redbud



Laurus 'Saratoga'
Saratoga Sweet Bay



Olea europaea 'Swan Hill'
Fruitless Olive Tree



Elaeocarpus decipiens
Japanese Blueberry Tree



Festuca glauca 'Elijah Blue'
Elijah Blue Fescue



Lavandula angustifolia
English Lavender



Lomandra longifolia 'Breeze'
Dwarf Mat Rush



Muhlenbergia capillaris 'Lenca'
Regal Mist Pink Muhly



Muhlenbergia rigens
Deer Grass



Miscanthus sinensis var. Condensatus
'Cabaret'



Miscanthus transmorrisonensis
Evergreen Miscanthus

G
Gaudet Design Group
Landscape Architecture
1756 23rd Street
Santa Monica, California 90404
310 828 4908 310 828 4906 Fax



PROJECT
1033 WEST 5TH ST
+
1046 WEST 6TH ST
CHICO, CALIFORNIA

SHEET TITLE
PLANT IMAGES

ISSUE
1 07-15-16 PLANNING SUBMITTAL

PHASE
Landscape Plan
(Site Design &
Architectural Review)
ORIGIN DATE 07-11-16
PLOT DATE 07-15-16
DRAWN BY: TP
CHECKED BY: DG

SHEET 6 of 9

L-2.2A



Platanus acerifolia
London Plane Tree



Quercus agrifolia
Coast Live Oak



Myrtus communis 'Compacta'
Dwarf Myrtle



Mahonia repens
Creeping Mahonia



Rhamnus californica 'Eve Case'
Coffeeberry



Thamnochortus insignis
Thatching Reed



Podocarpus elongatus 'Monval'
Icee Blue Yellow-wood



Rhamnus alaternus
Italian Buckthorn



Clytostoma callistegioides
Lavender Trumpet Vine



No-mow Fescue Sod

G
Gaudet Design Group
Landscape Architecture
1756 22nd Street
Santa Monica, California 90404
310 823 4908 310 823 4908 Fax



PROJECT
1033 WEST 5TH ST
+
1046 WEST 6TH ST
CHICO, CALIFORNIA

SHEET TITLE
PLANT IMAGES

ISSUE
1 07-15-16 PLANNING SUBMITTAL

PHASE
Landscape Plan
(Site Design &
Architectural Review)

ORIGIN DATE 07-11-16
PLOT DATE 07-15-16
DRAWN BY: TP
CHECKED BY: DG

SHEET 6 of 9
L-2.2B

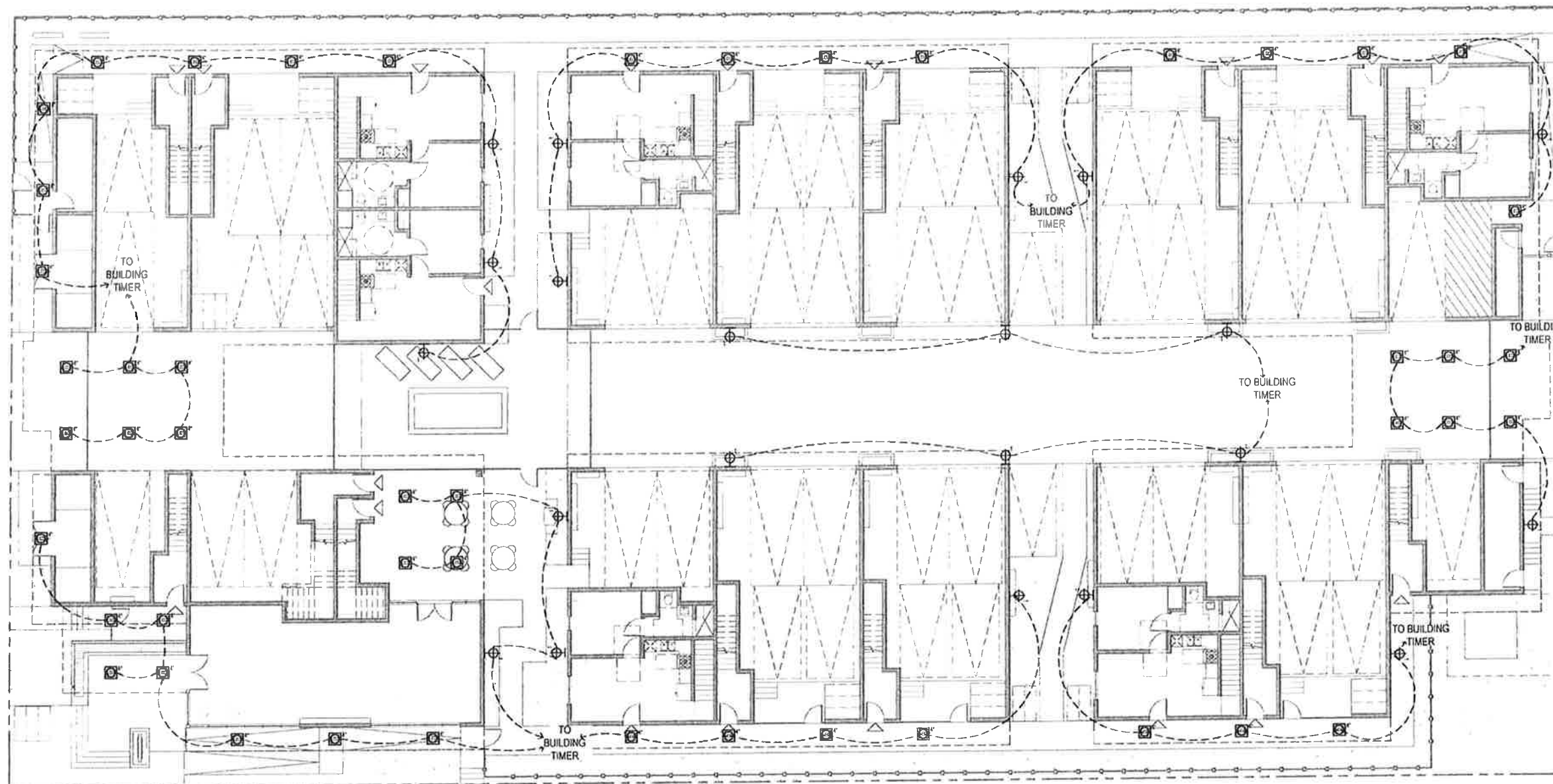

EXTERIOR GROUND LEVEL LIGHTING PLAN
 3/2" = 1'-0" 2

- LIGHTING, AV EQUIPMENT, AND ELECTRICAL NOTES**
- REVIEW ALL ELECTRICAL NOTES ON PLANS PRIOR TO BIDDING OR COMMENCING WORK
 - ALL LIGHTING AND ELECTRICAL COMPONENTS SHALL MEET THE REQUIREMENTS OF TITLE 24 AND TITLE 20 CALIFORNIA ENERGY CODES
 - ALL EXTERIOR LIGHTING SHALL BE ENERGY EFFICIENT, ARCHITECTURALLY INTEGRATED, DIRECTED DOWNWARD AND AWAY FROM ADJACENT PROPERTIES, AND SHIELDED OR RECESSED TO MINIMIZE GLARE AND REFLECTIONS TO THE SUBJECT SITE
 - PROVIDE ASTRONOMICAL TIMERS FOR ALL EXTERIOR LIGHTING (EXCLUDING FLOOD LIGHTS)
 - CALIFORNIA ENERGY CODE REQUIRES THAT ALL EXTERIOR LIGHTS BE HIGH EFFICACY OR BE PROVIDED WITH A MOTION SENSOR AND (EITHER A PHOTO CONTROL, OR ASTRONOMICAL TIMER)
 - PROVIDE HIGH EFFICACY LIGHTING IN ALL BATHROOMS OR PROVIDE VACANCY SENSORS
 - AT LEAST 50% OF THE TOTAL WATTAGE OF KITCHEN LIGHTING IS TO BE HIGH EFFICACY
 - PROVIDE HIGH EFFICACY LIGHTING AND VACANCY SENSORS IN ALL GARAGES, LAUNDRY, ROOMS AND UTILITY ROOMS
 - PROVIDE DIMMERS ON ALL OTHER INTERIOR LIGHTING OR PROVIDE VACANCY SENSORS OR HIGH EFFICACY LIGHTING (CLOSETS UNDER 70 SF EXEMPT)
 - EVERY SPACE INTENDED FOR HUMAN OCCUPANCY SHALL BE PROVIDED WITH NATURAL LIGHT BY MEANS OF EXTERIOR GLAZED OPENINGS IN ACCORDANCE WITH SECTION 1205.2 OR SHALL BE PROVIDED WITH ARTIFICIAL LIGHT THAT IS ADEQUATE TO PROVIDE AN AVERAGE ILLUMINATION OF 10 FOOT CANDLES OVER THE AREA OF THE ROOM AT A HEIGHT OF 30 INCHES ABOVE THE FLOOR LEVEL. (1205.1 AND 1205.3)
 - PROVIDE ARC FAULT CIRCUIT INTERRUPTER FOR ALL BRANCH CIRCUITS
 - PROVIDE RECEPTACLES @ EVERY 12'-0" THROUGHOUT AND @ 6'-0" FROM ANY DOOR OPENING UNLESS NOTED OTHERWISE
 - PROVIDE GROUND FAULT CIRCUIT INTERRUPTER RECEPTACLE BAT EVERY 4'-0" AND WITHIN 2'-0" OF A BREAK IN THE COUNTERTOP, IN ALL KITCHENS

- PROVIDE GROUND FAULT CIRCUIT INTERRUPTER RECEPTACLE PROTECTION FOR ALL RECEPTACLES IN BATH, GARAGE, OUTDOORS, UNDER-FLOOR SPACE, KITCHEN COUNTERS, UNFINISHED BASEMENTS AND LAUNDRY/UTILITY/WET BAR SINKS (WHERE THE RECEPTACLE IS WITHIN 6'-0" OF THE OUTSIDE SINK EDGE)
- PROVIDE A MINIMUM OF 2-20 AMP SMALL APPLIANCE BRANCH CIRCUITS FOR ALL RECEPTACLE OUTLETS IN THE KITCHEN, DINING ROOM, PANTRY, OR OTHER SIMILAR AREAS
- PROVIDE AT LEAST ONE 20 AMP BRANCH CIRCUIT TO SUPPLY BATHROOM RECEPTACLE OUTLETS. SUCH CIRCUITS SHALL HAVE NO OTHER OUTLETS
- PROVIDE AT LEAST ONE 20 AMP BRANCH CIRCUIT TO SUPPLY LAUNDRY RECEPTACLE OUTLETS. SUCH CIRCUITS SHALL HAVE NO OTHER OUTLETS
- 120V HARDWIRED SMOKE ALARMS WITH BATTERY BACK UP SHALL BE INSTALLED. WHERE ONE OR MORE SMOKE ALARMS IS REQUIRED TO BE INSTALLED WITHIN AN INDIVIDUAL DWELLING UNIT OR SLEEPING UNIT, THE SMOKE ALARMS SHALL BE INTERCONNECTED IN SUCH A MANNER THAT THE ACTIVATION OF ONE ALARM WILL ACTIVATE ALL THE ALARMS IN THE INDIVIDUAL UNIT. THE ALARM SHALL BE CLEARLY AUDIBLE IN ALL BEDROOMS OVER BACKGROUND NOISE LEVELS WITH ALL INTERVENING DOORS CLOSED. (IBC 907.2.10.1.2; 907.2.10.2; 907.2.10.3)
- SWITCHES, ALARM AND AUDIO VIDEO CONTROL LOCATIONS
 - ALL READ REQUIRED CONTROLS TO BE INSTALLED 5'-0" TO TOP OF COMPONENT
 - SWITCHES TO BE INSTALLED AT 2'-0" TO TOP OF SWITCH
- LOCATION OF LIGHTING, AV SYSTEM COMPONENTS, RECEPTACLES AND OTHER BUILT IN ELECTRICAL COMPONENTS TO BE REVIEWED AND APPROVED BY ARCHITECT PRIOR TO INSTALLATION
 - CONTRACTOR TO SCHEDULE JOB WALK WITH OWNER AND ARCHITECT PRIOR TO FINAL INSTALLATION. SPEAKER LAYOUT AND AV SYSTEM TO BE DETERMINED BY AN COMPANY AND APPROVED BY ARCHITECT
 - SCHEDULE AN ON-SITE MEETING WITH THE ARCHITECT FOR WALK THROUGH APPROVALS AT:
 - INITIAL WALK THROUGH PRIOR TO COMMENCING WORK AFTER ROUGH FRAMING IS COMPLETE
 - AFTER INSTALLATION OF ROUGHWHS (INCLUDING ALL RECEPTACLES, SWITCHES, AND J-BOXES) PRIOR TO WIRING

LIGHTING SYMBOLS		FOR LIGHTING SPECIFICATIONS, SEE A-XX-XX
LT-1		4" RECESSED CANS - LOW VOLTAGE
LT-2		4" RECESSED CANS - LED
LT-3		4" RECESSED CANS - LOW VOLTAGE - WET LOCATION
LT-4		4" RECESSED CANS - LED - WET LOCATION
LT-5		4" EXTERIOR RECESSED CANS - LOW VOLTAGE - ELITE 1462
LT-6		4" RECESSED CAN - LOW VOLTAGE - ELITE 1412 DOUBLE
LT-7		4" RECESSED CAN - LOW VOLTAGE - 90° - ELITE 1408
LT-8		SCONCE LIGHT - 1 - EXTERIOR

LT-9		4" FLUORESCENT LIGHT (DOUBLE LAMP)
LT-10		LED UNDER CABINET LIGHT
LT-11		STAIR LIGHT - INTERIOR
LT-12		FLOOD LIGHTS (DOUBLE LAMP) - PROVIDE SENSOR
LT-13		TIMER
LT-14		MOTION SENSOR
LT-15		PHOTO SENSOR

NOTES
 NO SCALE 3

LEGEND
 NO SCALE 1

A-5.10

TITLE: LIGHTING PLAN

NOT FOR CONSTRUCTION

September 22, 2016

THE URBAN - NEW APARTMENT COMPLEX
 1033 W. 5th Street + 1046 W. 6th Street
 Chico, CA 95928

L+V architects
 2332 COTNER AVE, SUITE 303
 WEST LOS ANGELES, CA
 TEL: 310.914.5577
 WWW.LVARCH.COM

LUMINAIRE SCHEDULE

TYPE	LAMPS	DESCRIPTION	MFR
1	16W LED	WALL SCONCE, DIE CAST ALUMINUM, WET LOCATION RATED, DOWNWARD MOUNT, DARK SKY FRIENDLY, ETCHED GLASS, BRONZE HOUSING, 3000K, 70,000 HRS, 120VAC.	WAC WS-W2509-BZOR EQUAL
2	18W LED	6" LED RECESS CAN, WHITE APERTURE/TRIM COLOR, SEMI SPECULAR FINISH, 0-10V DIMMING DRIVER/LED RATED FOR L70/60,000 HRS, WIDE DISTRIBUTION, 1000 LUMENS, 3000K, 120VAC, EMERGENCY BATTERY POWER WHERE SHOWN ON PLANS. PROVIDE AND INSTALL TENT MATS FOR SPACES WHERE LUMINAIRE SHALL HAVE CONTACT WITH INSULATION OR OTHER FLAMMABLE MATERIALS.	GOTHAM EVO-VR; OR EQUAL

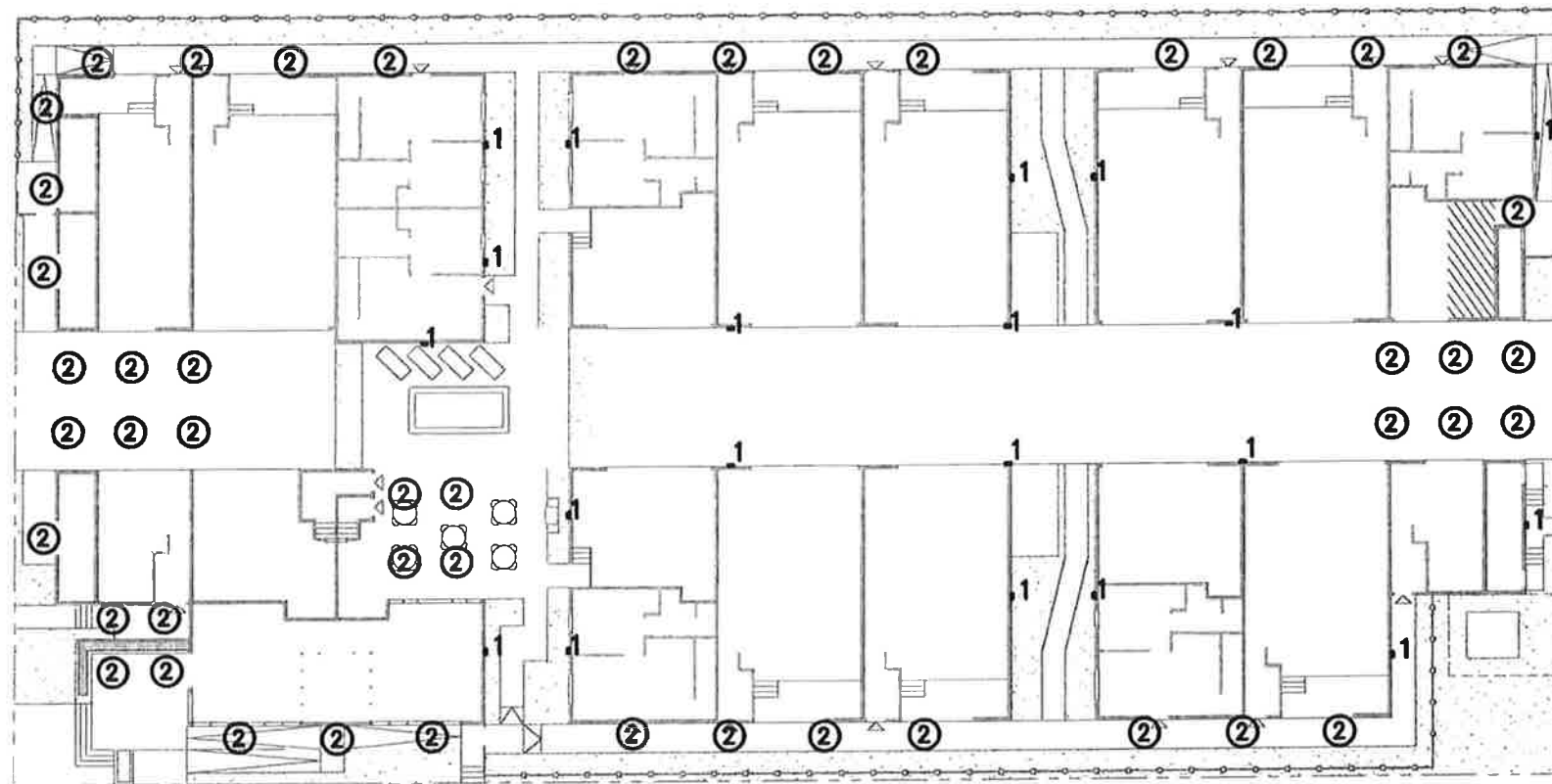

Plot Date: September 21, 2016 - 7:18 am
 File Name: M:\Land Projects\256201 Chico Apartment Complex\DWG\E001.dwg, Layout: 11X17
 Login Name: bewing

L+V architects
 2332 COTNER AVE, SUITE 303
 LOS ANGELES, CA 90064
 T 310.914.5577
 WWW.LVARCH.COM

THE URBAN - NEW APARTMENT COMPLEX
 1033 W. 6th Street + 1046 W. 6th Street
 Chico, CA 95928

TITLE: PHOTOMETRIC SITE PLAN

NOT FOR CONSTRUCTION

September 19, 2016

PHOTOMETRIC SITE PLAN
1" = 30'-0" 1

E-0.01



PROJECT
 1033 WEST 5TH ST
 +
 1046 WEST 6TH ST
 CHICO, CALIFORNIA

SHEET TITLE
 LIGHTING PLAN

ISSUE
 1 08.08.16 PLANNING SUBMITTAL

PHASE
 Landscape Plan
 (Site Design &
 Architectural Review)

ORIGIN DATE 07-11-16
 PLOT DATE 08-08-16
 DRAWN BY: TP
 CHECKED BY: DG

SHEET 9 of 9

L-4.0A

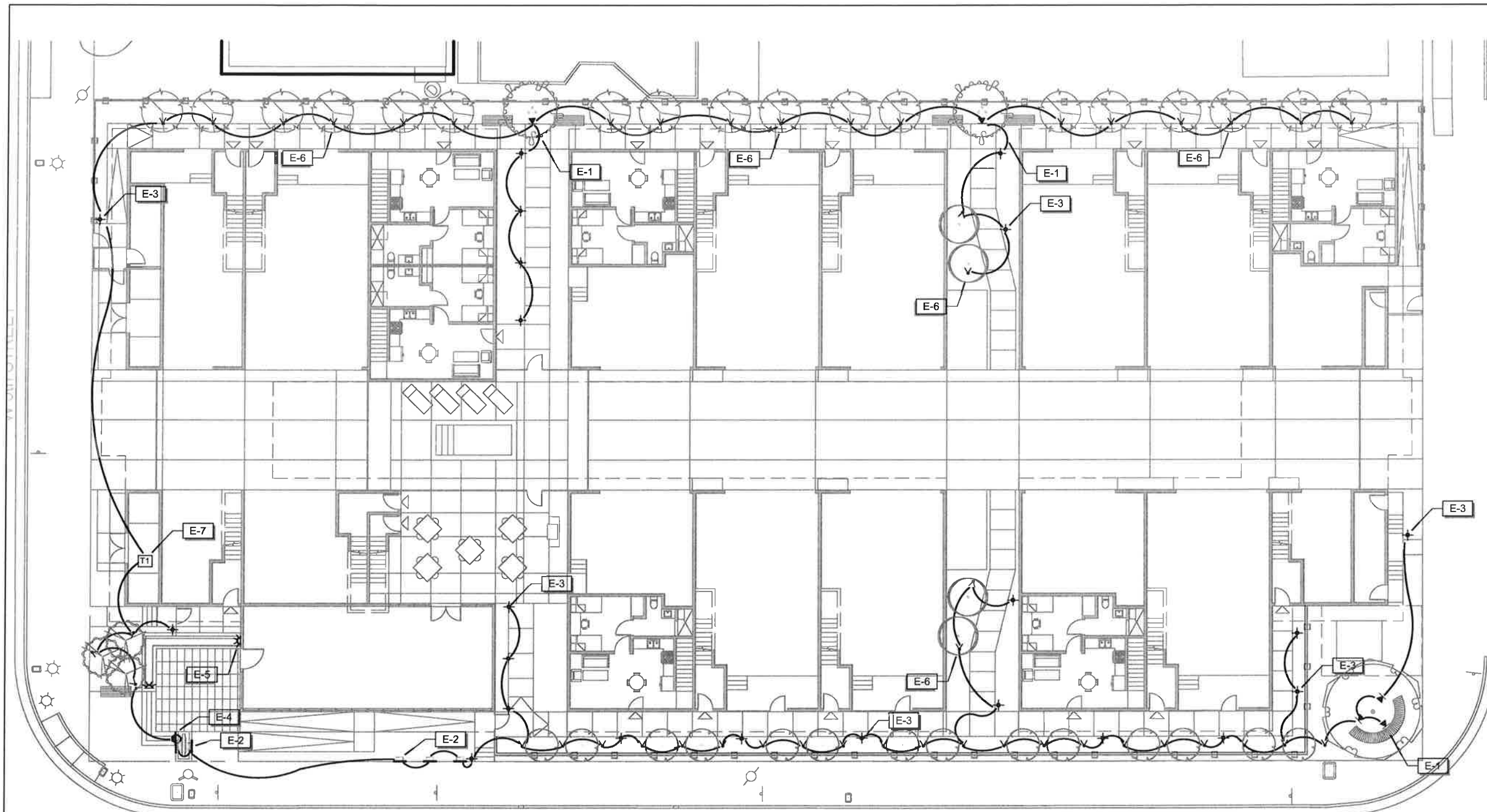







WALNUT STREET
 (STATE HIGHWAY 32)



SCALE: 1/8" = 1'-0"

LIGHTING LEGEND

FIXTURE	SYM.	DESCRIPTION	MANUFACTURER	CATALOG NUMBER	LAMP	FINISH	QUANTITY	NOTES
E-1		TREE UP-LIGHT	SPJ LIGHTING	TITAN	7 WATT LED	MATTE BRONZE	5	MOUNT ON SPJ PERMA POST WITH 6" RISER
E-2		WASH LIGHT	SPJ LIGHTING	SPJ-MWW1	7 WATT LED	MATTE BRONZE	5	MOUNT ON SPJ DUAL FIN SPIKE WITH 6" RISER
E-3		PATH LIGHT	SPJ LIGHTING	SPJ18-16	5 WATT FB LED	MATTE BRONZE	22	NO SHROUD. 19-03 PERMAPOST WITH MATTE BLACK CAP
E-4		PATH LIGHT	SPJ LIGHTING	SPJ-GDG-30W-SQ-SH	3 WATT FB LED	MATTE BRONZE	1	WALL MOUNT
E-5		FOUNTAIN LIGHT	SaVi	SaVi-MB 100 MELODY BLANCO	28 WATT LED	STAINLESS STEEL	2	
E-6		UP-LIGHT	SPJ LIGHTING	SUPER NOVA	5 WATT LED	MATTE BRONZE	46	MOUNT ON 19-03 PERMAPOST WITH 12" RISER
E-7	T#	TRANSFORMER	SPJ LIGHTING	T1: MTP600-SS			1	PHOTO CELL & TIMER. LOCATED IN TRASH AREA
		LOW VOLT WIRE						12 GUAGE DIRECT BURIAL

LIGHTING NOTES

LOW VOLTAGE LANDSCAPE LIGHTING INSTALLATION NOTES & SPECS:

GENERAL:

SCOPE OF WORK: THE SUPPLY AND INSTALLATION OF BUILDING AND LANDSCAPE LIGHTING SYSTEM WHICH INCLUDES THE FIXTURES SPECIFIED ON THE FIXTURE SCHEDULE AS WELL AS ANY LOW VOLTAGE TRANSFORMERS NECESSARY TO COMPLETE THE PLAN/ELEVATION AS SHOWN. THIS LIGHTING PLAN/ELEVATION IS DIAGRAMATIC AND IS INTENDED TO SHOW GENERAL FIXTURE LOCATION AND UTILITIES. THE CONTRACTOR IS RESPONSIBLE FOR NECESSARY LINE (120-VOLT) AND LOW (12-VOLT) WORK TO COMPLETE THE LIGHTING DESIGN AS SHOWN.

STANDARDS:

ALL WORK PERFORMED IS TO COMPLY WITH THE UNIFORM BUILDING CODE, CALIFORNIA ELECTRICAL CODE TITLE 8, AND ALL APPLICABLE LOCAL CODES AND ORDINANCES. THE CONTRACTOR SHALL POSSES ALL NECESSARY LICENSES TO COMPLETE THE DESCRIBED WORK AND SHALL DETERMINE THE NECESSARY PANELS, BREAKERS, CONDUIT, WIRE, WIRING DEVICES, INVOLVED WITH THIS INSTALLATION. THE CONTRACTOR SHALL PROVIDE ALL NECESSARY COMPONENTS AND ACCESSORIES TO COMPLETE THE INSTALLATION AS DESIGNED.

INSTALLATION:

THE CONTRACTOR IS TO VERIFY THE SITE, WALKWAYS, STAIRS, PLANTINGS, BUILDINGS, AND OTHER ELEMENTS, WHICH AFFECT THE INSTALLATION. THE CONTRACTOR SHALL VERIFY THE EXISTING ELECTRICAL SERVICE, DISTRIBUTING AND PANEL LOCATIONS. THE CONTRACTOR SHALL DETERMINE THE NECESSARY PANELS, BREAKERS, CONDUIT, WIRE, WIRING DEVICES INVOLVED WITH THIS INSTALLATION AS DESIGNED. THE CONTRACTOR SHALL PROVIDE ALL NECESSARY COMPONENTS AND ACCESSORIES TO COMPLETE THE INSTALLATION AS DESIGNED.

TRANSFORMERS:

TRANSFORMERS SHALL BE LOCATED IN APPROPRIATE MECHANICAL ROOM. INSTALL TRANSFORMERS MIN. 12" ABOVE FINISH GRADE AND LEVEL. ALL WIRES LEADING TO OR

FROM THE TRANSFORMER SHALL BE IN CONDUIT SLEEVE THAT IS FIRMLY AFFIXED TO MOUNTING SURFACE. ALL JUNCTION BOXES AND OTHER EQUIPMENT SHALL BE UL APPROVED FOR WET LOCATIONS. INSTALL TRANSFORMERS SHALL BE INSTALLED IN COMPLIANCE WITH THE MANUFACTURER'S SPECIFICATIONS AND APPLICABLE CODES. ALL TRANSFORMERS SHALL BE CONNECTED TO GFI RATED DUPLEX OUTLETS IN WET LOCATION RATED ELECTRICAL BOXES. TRANSFORMERS SHALL BE CLEARLY AND NEATLY MARKED WITH WATER PROOF MARKING INDICATING THE TRANSFORMER NUMBER, CIRCUIT TO WHICH THE TRANSFORMER IS CONNECTED AND THE FIXTURE GROUP BEING POWERED BY THE TRANSFORMER.

TESTING:

THE CONTRACTOR SHALL COORDINATE A CONVENIENT TIME IN THE EVENING TO TEST AND FOCUS ALL EQUIPMENT TO THE SATISFACTION OF THE LANDSCAPE ARCHITECT AND OWNER.

FIXTURE LOCATIONS:

VERIFY EXACT LOCATION WITH THE LANDSCAPE ARCHITECT, OR THE OWNER BEFORE STARTING THE WORK. ALL FIXTURES SHALL BE NEW, UNUSED CONDITION. EQUIPMENT SHALL BE THE TYPE SPECIFIED. SUBSTITUTIONS SHALL BE APPROVED PRIOR TO INSTALLATION OR ARE INSTALLED AT THE CONTRACTOR'S RISK. LIGHTING FIXTURES SHALL BE INSTALLED AS SPECIFIED BY THE MANUFACTURER.

GUARANTEE:

UPON COMPLETION AND ACCEPTANCE OF THE WORK, THE CONTRACTOR SHALL PROVIDE A GUARANTEE FOR ALL WORKMANSHIP AND EQUIPMENT FURNISHED AND INSTALLED BY THE CONTRACTOR FOR A PERIOD OF ONE YEAR FROM THE DATE OF ACCEPTANCE. WARRANTY WORK SHALL BE PERFORMED AT NO COST TO THE OWNER AND SHALL BE DONE ON A TIMELY BASIS.



PROJECT
1033 WEST 5TH ST
+
1046 WEST 6TH ST
CHICO, CALIFORNIA

SHEET TITLE
LIGHTING PLAN

ISSUE
1 08.08.16 PLANNING SUBMITTAL

PHASE
Landscape Plan
(Site Design &
Architectural Review)

ORIGIN DATE 07-11-16
PLOT DATE 08-08-16
DRAWN BY: TP
CHECKED BY: DG

SHEET 9 of 9



SCALE: 1/8" = 1'-0"

L-4.0B

L+V architects
 2332 COTNER AVE, SUITE 303
 WEST LOS ANGELES, CA
 90061
 T: 310.914.6577
 WWW.LVARCH.COM

THE URBAN - NEW APARTMENT COMPLEX
 1033 W. 5th Street + 1046 W. 8th Street
 Chico, CA 95928

TITLE: SIGNAGE
NOT FOR CONSTRUCTION

September 22, 2016

A-6.30

SIGNAGE TABULATION	
SIGN AREA (per side)	12 SF (144 sq.in.)
SIGN HEIGHT	
WITHOUT CONCRETE BASE	30"
WITH CONCRETE BASE	64"
SIGN WIDTH	
WITHOUT CONCRETE BASE	12"
WITH CONCRETE BASE	39"
SIGN LENGTH	
WITHOUT CONCRETE BASE	57"
WITH CONCRETE BASE	81"

SIGNAGE TABULATION

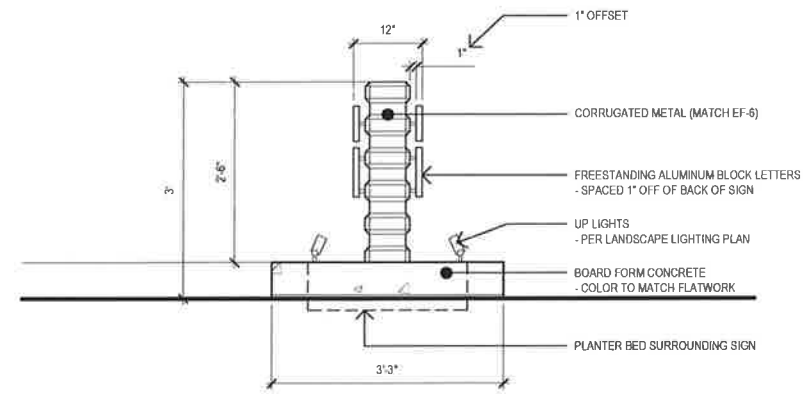

SIGN ELEVATION D

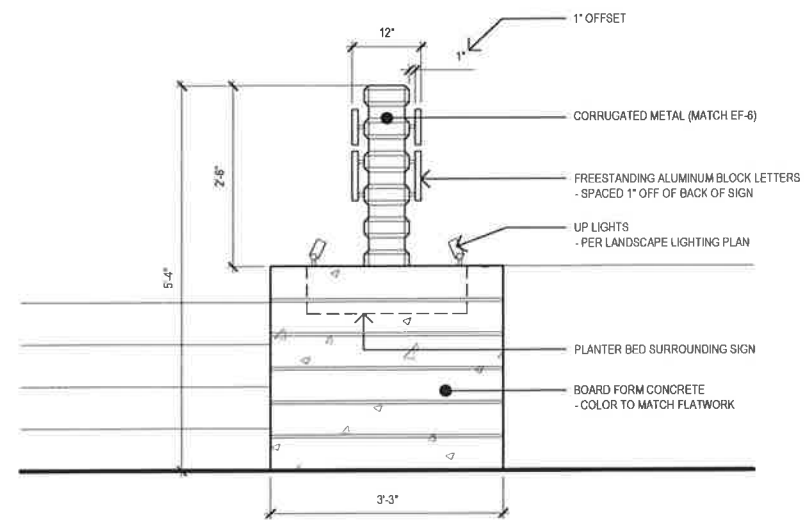

SIGN ELEVATION C

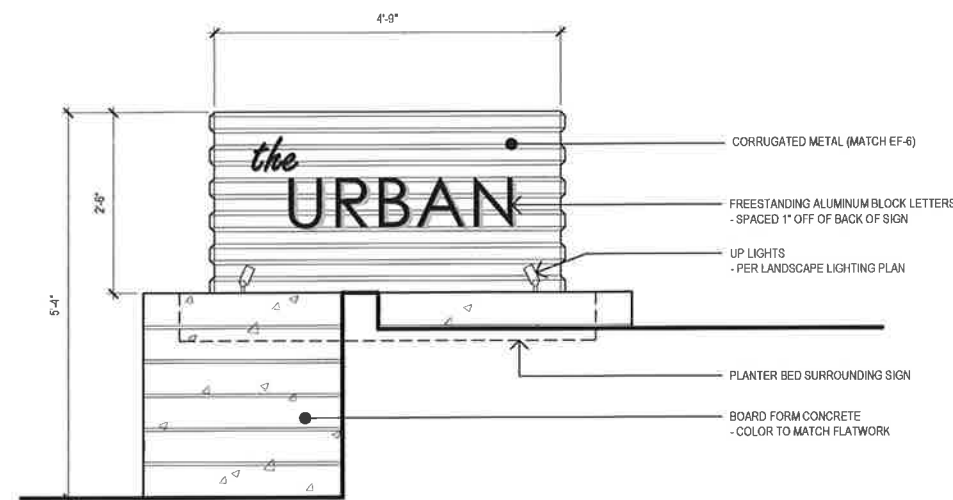

SIGN ELEVATION B

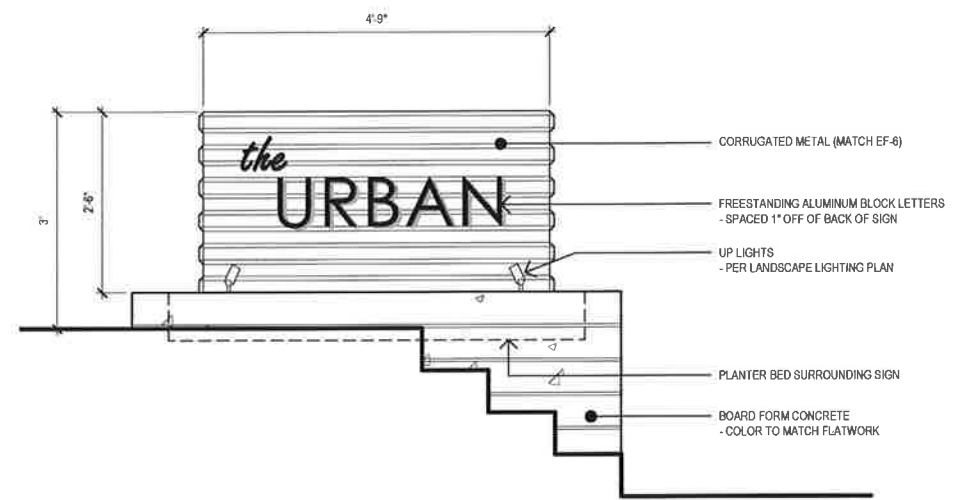

SIGN ELEVATION A

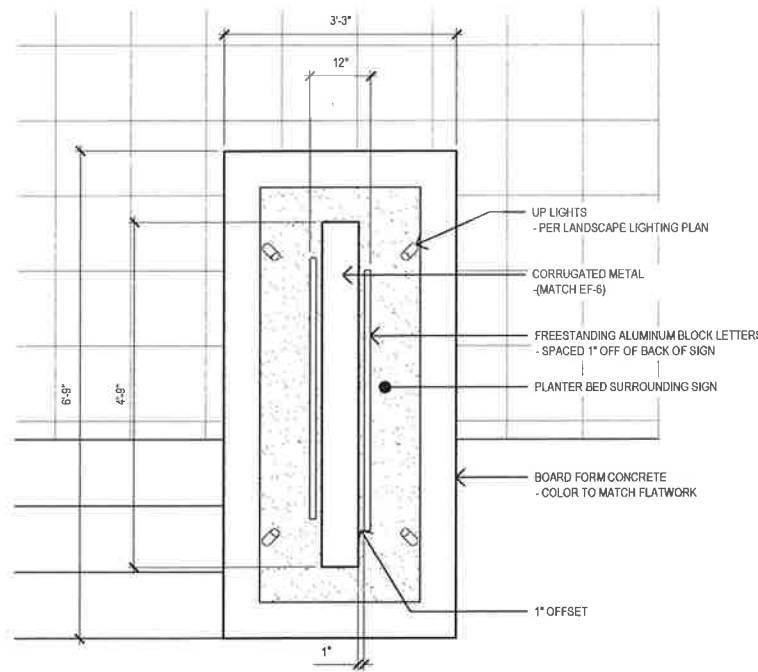

SIGN FLOOR PLAN

Project: The Urban – Walnut Street Apartments

September 26, 2016

City of Chico Planning Department
411 Main Street – 2nd Floor
P.O. Box 3420
Chico, CA 95927

RE: Letter of Explanation for PDP case (1033 W. 5th Street and 1046 W. 6th Street)

To Whom it May Concern,

We are requesting code relief from Chico municipal code section 19.70.060E(2) which requires that "...at least 50 percent of the total paving area, not including the entrance drives, parking areas under carports...shall be shaded at solar noon on June 21." We believe that the intent of the code here is to provide a degree of protection from the heat generated due to a vehicle parked in the full sun, and secondly, to protect against the "heat-island" effect of unprotected paving holding and radiating heat for a long duration. We also believe that this code section was drafted with typical at grade parking lots in mind and does not allow for unique building/parking configurations such as those utilized by our proposed project. We firmly believe that our project meets the intent of the code and that support of our request can be made through any one of the code interpretations indicated below.

In the case of our proposed project on Walnut Street over 95% of the provided parking is covered, but not by carports, rather by the building itself. This configuration is referred to as "tuck under parking". Since we have a greater square footage of the covered paving than the uncovered, we exceed the shading requirement. The total parking area is 14,915 SF (entrance drive aisles and parking stall areas combined) with 2,946 SF of the entrance drive aisles not covered by the proposed building. Therefore, over 83% of the total parking area of the project is in shade full time throughout the day far exceeding the 50% requirement.

However, if we are obligated to discount the actual parking spaces for the purposes of the calculation, then we are left with only the entrance drive aisles leading to the parking spaces. It could be considered that these entrance drive lanes themselves are "entrance drives" as they are the direct route from the public way to the parking spaces with no turns until entering the actual parking spaces. If this interpretation is agreeable to staff then we have no paving to shade and, therefore, we meet the requirement.

Should staff not agree with the interpretation in the preceding paragraph then a second solution would be to analyze the shading of the entrance drive aisles at noon on June 21st as the code indicates. As proposed the entrance drive aisles constitute a total area of 5,313 SF with 2,193 SF (41%) of that directly covered by the building. However, this figure does not account for shadows cast by the building which puts a further amount of the entrance drive aisles in shade. Based on solar shade studies done using 3D Modeling software that incorporates solar paths throughout the day/year (see attached Model Images), at noon on June 21st 3,333 SF of the entrance drive aisles are in shade. This results in 63% of the entrance drive aisles being in shade on June 21st at 12:00 noon.

We feel strongly that the intent of the code is being met in that well over 50% of the paved areas provided for parking are in shade at the designated time of day/year. As such we are requesting that planning staff support our PDP request to allow the required shading to be provided by the building in lieu of the required trees.

Thank you for your consideration of our request.

Sincerely,

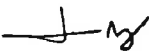

Tarek Abdel-Ghaffar
Principal
Colega Architects

Project: The Urban – Walnut Street Apartments

SHADE STUDY MODEL IMAGES

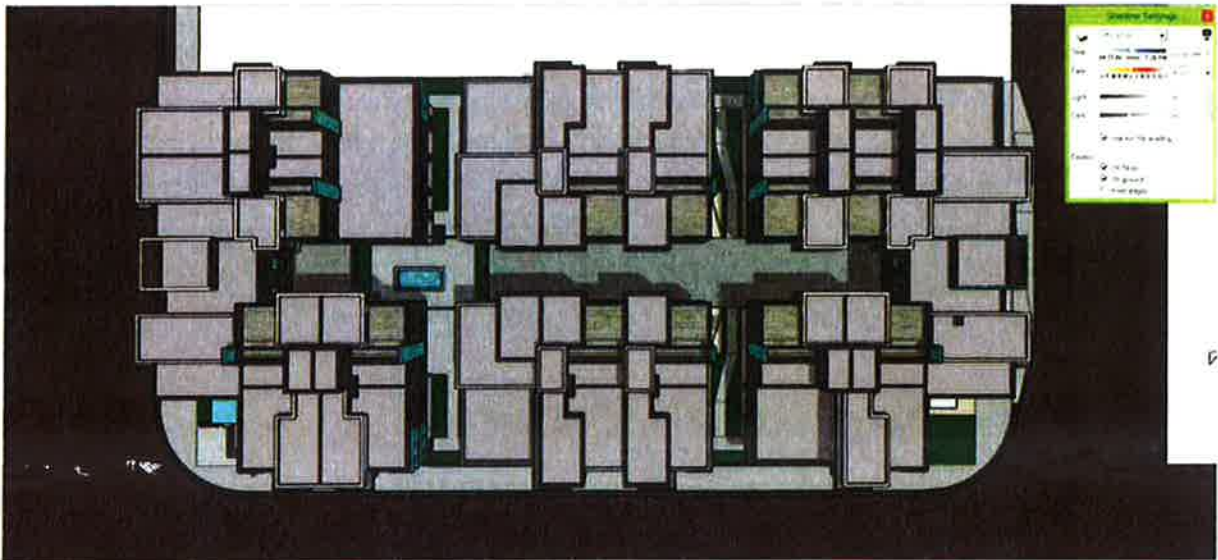

Aerial View of overall site showing shading at 12:00 noon on 6/21



View From 6th Street vehicular entrance showing shading at 12:00 noon on 6/21

RECEIVED

SEP 26 2016

**CITY OF CHICO
PLANNING SERVICES**

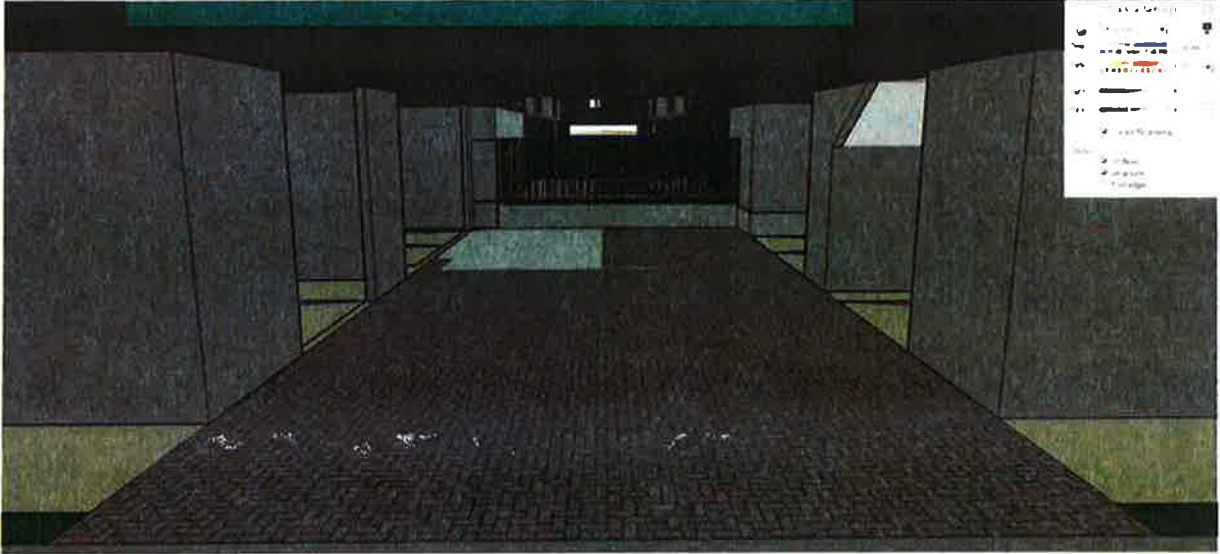

View From 5th Street vehicular entrance showing shading at 12:00 noon on 6/21